

# SACHIYA STEEL INTERNATIONAL

( A HUB OF QUALITY )

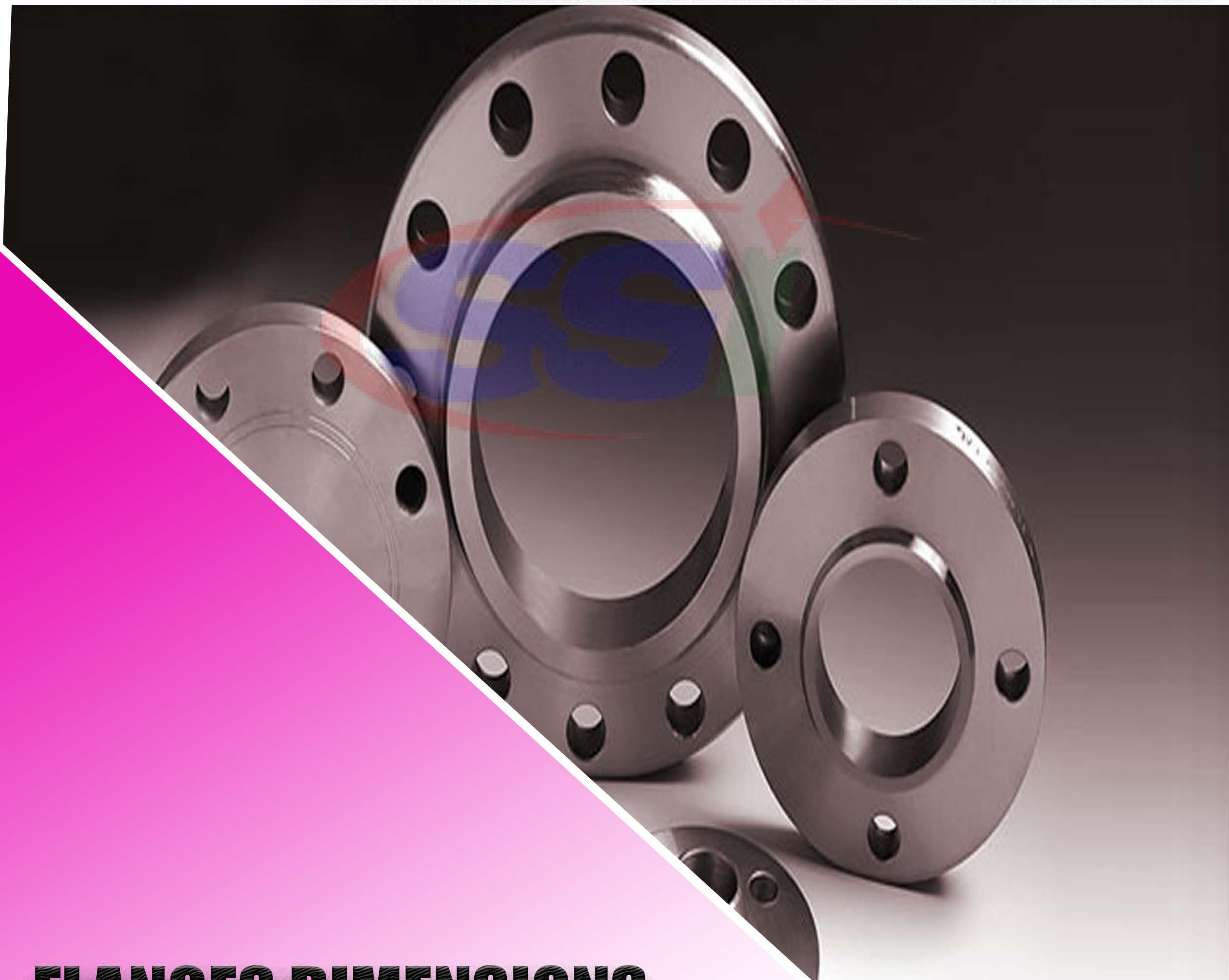

**AN ISO 18001:2007 , 9001:2015 TUV Certified Co. | IBR APPROVED**



**FLANGES DIMENSIONS**



## FLANGES TO ANSI B16.5 / 16.47 / 16.10 / 16.36 / 16.48

### Material

Flanges are forged from material conforming to ASTM A 105 NORMALISED ASTM A 350-LF2, ASTM A694 F52, 65 ASTM A 182 and Duplex Steels, B564, B637, B462 etc.

### Dimensions

All dimensions comply with the Standard. Flanges are machined on the outside diameter, bore (and weld preparation of weld necks) and joint face. Bolt holes are drilled Weld prep on weldnecks is to ANSI B16.25.

### Marking

Flanges are marked with : the nominal size : class number ; material grade heat WT number' manufacturer's mark.

### Test Certificate

Flanges test certificates are available and are supplied with all goods. Test Certificates include full chemical analysis and Mechanical With Carbon Equivalent Properties with 3.1 certificate, Impact test & NACE MR 0175 / MR 0103 in addition as per requirement.

### Inspection

All stock is statically sample inspected on receipt.

### Manufacturing Capability

<u>Dimensional Standard</u>	<u>Size Range</u>	<u>Rating</u>
ASME / ANSI / B 16.5	½" to 24"	Class 150 to 2500 Lbs
MSS-SP-44	12" to 60"	Class 150 to 900 Lbs
ASME / B16.47 / API 605	26" to 60"	-
ASME / ANSI / B 16.36	1" to 24"	Class 300 to 2500 Lbs
BS 3293	26" to 48"	Class 150 to 600 Lbs
ASME / B 16.48 / API 590	½" to 24"	Class 150 to 2500 Lbs
API 6A	2 1/16" to 30"	2000 Psi to 20000 Psi
DIN	DN10 to DN3600	PN6 to PN 160





## DIMENSIONS OF FORGED FLANGES ANSI 16.5

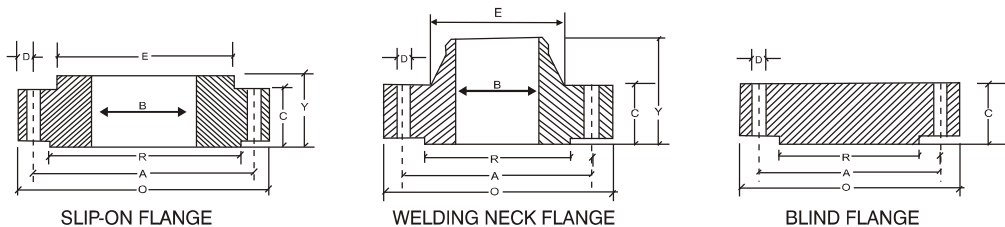

### ASA 150 CLASS

Nominal Pipe Size	Flange Dia	Dia of Bolt Circle	Dia of Bolt Holes	No. of Holes	Thk of Flange	Dia of Hub	Length Through Hub			Dia of Bore		Dia of R/F	Depth of Socket	Pipe Dia	
							S/O & S/W	W/N	L/J	S/O & S/W	L/J				
(MM)	(INCH.)	O	A	D	C	E	Y	Y	Y	B	B	R	F	X	
15	1/2	88.9	60.3	15.9	4	11.1	30.2	15.9	47.6	15.9	22.3	22.9	34.9	9.5	21.33
20	3/4	98.4	69.8	15.9	4	12.7	38.1	15.9	52.4	15.9	27.7	28.2	42.9	11.1	26.67
25	1	107.9	79.4	15.9	4	14.3	49.2	17.5	55.6	17.5	34.5	35.0	50.8	12.7	33.40
32	1 1/4	117.5	88.9	15.9	4	15.9	58.7	20.6	57.1	20.6	43.2	43.7	63.5	14.3	42.16
40	1 1/2	127.0	98.4	15.9	4	17.5	65.1	22.2	61.9	22.2	49.5	50.0	73.0	15.9	48.26
50	2	152.4	120.6	19.0	4	19.0	77.8	25.4	63.5	25.4	62.0	62.5	92.1	17.5	60.31
65	2 1/2	177.8	139.7	19.0	4	22.2	90.5	28.6	69.8	28.6	74.7	75.4	104.8	19.0	73.02
80	3	190.5	152.4	19.0	4	23.8	107.9	30.2	69.8	30.2	90.7	91.4	127.0	20.6	88.90
100	4	228.6	190.5	19.0	8	23.8	134.9	33.3	76.2	33.3	116.1	116.8	157.2	23.8	114.30
125	5	254.0	215.9	22.2	8	23.8	163.5	36.5	88.9	36.5	143.8	144.5	185.7	23.8	141.30
150	6	279.4	241.3	22.2	8	25.4	192.1	39.7	88.9	39.7	170.7	171.4	215.9	27.0	168.27
200	8	342.9	298.4	22.2	8	28.6	246.1	44.4	101.6	44.4	221.5	222.2	269.9	31.7	219.07
250	10	406.4	361.9	25.4	12	30.2	304.8	49.2	101.6	49.2	276.3	277.4	323.8	33.3	273.05
300	12	482.6	431.8	25.4	12	31.8	365.1	55.6	114.3	55.6	327.1	328.2	381.0	39.7	323.85
350	14	533.4	476.2	28.6	12	34.9	400.0	57.1	127.0	57.1	359.1	360.2	412.7	41.3	355.60
400	16	596.9	539.7	28.6	16	36.5	457.2	63.5	127.0	87.3	410.5	411.2	469.9	44.4	406.40
450	18	635.0	577.8	31.7	16	39.7	504.8	68.3	139.7	96.8	461.8	462.3	533.4	49.2	457.20
500	20	698.5	635.0	31.7	20	42.9	558.8	73.0	144.5	103.2	513.1	514.3	584.2	54.0	508.00
600	24	812.8	749.3	34.9	20	47.6	663.6	82.5	152.4	111.1	615.9	615.9	692.1	63.5	609.60

All Dimensions are in Millimeters • Flanges except Lap Joint will be furnished with (1.6mm) Raised Face, which is included in Thickness(C) and Length through Hub(Y).

### ASA 300 CLASS

Nominal Pipe Size	Flange Dia	Dia of Bolt Circle	Dia of Bolt Holes	No. of Holes	Thk of Flange	Dia of Hub	Length Through Hub			Dia of Bore		Dia of R/F	Depth of Socket	Pipe Dia	
							S/O & S/W	W/N	L/J	S/O & S/W	L/J				
(MM)	(INCH.)	O	A	D	C	E	Y	Y	Y	B	B	R	F	X	
15	1/2	95.2	66.7	15.9	4	14.3	38.1	22.2	52.4	22.2	22.3	22.9	34.9	9.5	21.33
20	3/4	117.5	82.5	19.0	4	15.9	47.6	25.4	57.1	25.4	27.7	28.2	42.9	11.1	26.67
25	1	123.8	88.9	19.0	4	17.5	54.0	27.0	61.9	27.0	34.5	35.0	50.8	12.7	33.40
32	1 1/4	133.3	98.4	19.0	4	19.0	63.5	27.0	65.1	27.0	43.2	43.7	63.5	14.3	42.16
40	1 1/2	155.6	114.3	22.2	4	20.6	69.8	30.2	68.3	30.2	49.5	50.0	73.0	15.9	48.26
50	2	165.1	127.0	19.0	8	22.2	84.1	33.3	69.8	33.3	62.0	62.5	92.1	17.5	60.31
65	2 1/2	190.5	149.2	22.2	8	25.4	100.0	38.1	76.2	38.1	74.7	75.4	104.8	19.0	73.02
80	3	209.5	168.3	22.2	8	28.6	117.5	42.9	79.4	42.9	90.7	91.4	127.0	20.6	88.90
100	4	254.0	200.0	22.2	8	31.8	146.0	47.6	85.7	47.6	116.1	116.8	157.2	23.8	114.30
125	5	279.4	234.9	22.2	8	34.9	177.8	50.8	98.4	50.8	143.8	144.5	185.7	-	141.30
150	6	317.5	269.9	22.2	12	36.5	206.4	52.4	98.4	52.4	170.7	171.4	215.9	-	168.27
200	8	381.0	330.2	25.4	12	41.3	260.3	61.9	111.1	61.9	221.5	222.2	269.9	-	219.07
250	10	444.5	387.3	28.6	16	47.6	320.7	66.7	117.5	95.2	276.3	277.4	323.8	-	273.05
300	12	520.7	450.8	31.7	16	50.8	374.6	73.0	130.2	101.6	327.1	328.2	381.0	-	323.85
350	14	584.2	514.3	31.7	20	54.0	425.4	76.2	142.9	111.1	359.1	360.2	412.7	-	355.60
400	16	647.7	571.5	34.9	20	57.2	482.6	82.5	146.0	120.6	410.5	411.2	469.9	-	406.40
450	18	711.2	628.5	34.9	24	60.3	533.4	88.9	158.7	130.2	461.8	462.3	533.4	-	457.20
500	20	774.7	685.8	34.9	24	63.5	587.4	95.2	161.9	139.7	513.1	514.3	584.2	-	508.00
600	24	914.4	812.8	41.3	24	69.8	701.7	106.4	168.3	152.4	615.9	615.9	692.1	-	609.60

All Dimensions are in Millimeters • Flanges except Lap Joint will be furnished with (1.6mm) Raised Face, which is included in Thickness(C) and Length through Hub(Y).

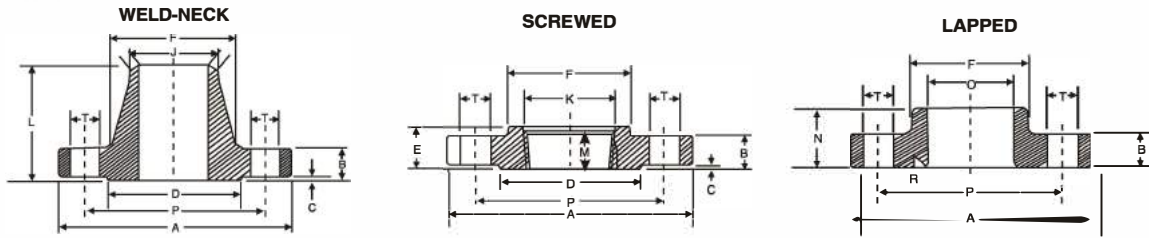

### DIMENSIONS OF CLASS 600 FLANGES AS PER ANSI B 16.5

N.H.	A	B	C	D	E	F	G	H	J	K	L	M	N	O	P	R	T	No.
15	95	14.3	6.4	35	22	38	22.4	9.5	21.3	23.5	52	16	22	23.0	66.7	3.0	15.9	4
20	117	15.9	6.4	43	25	48	27.7	11.0	26.7	29.0	57	16	25	28.0	82.6	3.0	19.0	4
25	124	17.5	6.4	51	27	54	34.5	12.5	33.4	36.0	62	17	27	35.0	88.9	3.0	19.0	4
32	133	20.6	6.4	64	29	64	43.2	14.5	42.2	44.5	67	21	29	43.5	98.4	5.0	19.0	4
40	156	22.2	6.4	73	32	70	49.5	16.0	48.3	50.5	70	22	32	50.0	114.3	6.5	22.2	4
50	165	25.4	6.4	92	37	84	62.0	17.5	60.3	63.5	73	29	37	62.5	127.0	8.0	19.0	8
65	190	28.6	6.4	105	41	100	74.7	19.0	73.0	76.0	79	32	41	75.5	149.2	8.0	22.2	8
80	210	31.8	6.4	127	46	117	90.7	20.5	88.9	92.0	83	35	46	91.5	168.3	9.5	22.2	8
90	229	34.9	6.4	140	49	133	103.4	-	101.6	105.0	86	40	49	104.0	184.2	9.5	25.4	8
100	273	38.1	6.4	157	54	152	116.1	-	114.3	118.0	102	41	54	117.0	215.9	11.0	25.4	8
125	330	44.4	6.4	186	60	189	143.8	-	141.3	145.0	114	48	60	145.0	266.7	11.0	28.6	8
150	356	47.6	6.4	216	67	222	170.7	-	168.3	171.0	117	51	67	171.0	292.1	12.5	28.6	12
200	419	55.6	6.4	270	76	273	221.5	-	219.1	222.0	133	57	76	222.0	349.2	12.5	31.8	12
250	508	63.5	6.4	324	86	343	276.4	-	273.0	276.0	152	65	111	277.0	431.8	12.5	34.9	16
300	559	66.7	6.4	381	92	400	327.2	-	323.9	329.0	156	70	117	328.0	489.0	12.5	34.9	20
350	603	69.8	6.4	413	94	432	359.2	-	355.6	360.0	165	73	127	360.0	527.0	12.5	38.1	20
400	686	76.2	6.4	470	106	495	410.5	-	406.4	411.0	178	78	140	411.0	603.2	12.5	41.3	20
450	743	82.6	6.4	533	117	546	461.8	-	457.2	462.0	184	79	152	462.0	654.0	12.5	44.4	20
500	813	88.9	6.4	584	122	610	513.1	-	508.0	513.0	190	83	165	514.0	723.9	12.5	44.4	24
600	940	101.6	6.4	692	140	718	616.0	-	609.6	614.0	203	92	184	616.0	838.2	12.5	50.8	24

### DIMENSIONS OF CLASS 900 FLANGES AS PER ANSI B 16.5

N.	A	B	C	D	E	F	G	H	J	K	L	M	N	O	P	R	T	No.
15	121	22.2	6.4	35	32	38	22.4	9.5	21.3	23.5	60	22	32	23.0	82.6	3.0	22.2	4
20	130	25.4	6.4	43	35	44	27.7	11.0	26.7	29.0	70	25	35	28.0	88.9	3.0	22.2	4
25	149	28.6	6.4	51	41	52	34.5	12.5	33.4	36.0	73	29	41	35.0	101.6	3.0	25.4	4
32	159	28.6	6.4	64	41	64	43.2	14.5	42.2	44.5	73	30	41	43.5	111.1	5.0	25.4	4
40	178	31.8	6.4	73	44	70	49.5	16.0	48.3	50.5	83	32	44	50.0	123.8	6.5	28.6	4
50	216	38.1	6.4	92	57	105	62.0	17.5	60.3	63.5	102	38	57	62.5	165.1	8.0	25.4	8
65	244	41.3	6.4	105	64	124	74.7	19.0	73.0	76.0	105	48	64	75.5	190.5	8.0	28.6	8
80	267	47.6	6.4	127	73	133	-	-	88.9	92.0	117	51	73	91.5	203.2	9.5	31.8	8
100	311	54.0	6.4	157	91	162	-	-	114.3	118.0	124	57	91	117.0	241.3	11.0	34.9	8
125	325	73.0	6.4	186	105	197	-	-	141.3	145.0	156	64	105	145.0	292.1	11.0	41.3	8
150	394	82.6	6.4	216	119	229	-	-	168.3	171.0	171	70	119	171.0	317.5	12.5	38.1	12
200	483	92.1	6.4	270	143	292	-	-	219.1	222.0	213	75	143	222.0	393.7	12.5	44.4	12
250	584	108.0	6.4	324	159	368	-	-	273.0	276.0	254	84	178	277.0	482.6	12.5	50.8	12
300	673	123.8	6.4	381	181	451	-	-	323.9	329.0	283	92	219	328.0	571.5	12.5	54.0	16
350	749	133.4	6.4	413	-	495	-	-	356.6	-	298	-	241	360.0	635.0	12.5	60.3	16
400	826	146.1	6.4	470	-	552	-	-	406.4	-	311	-	260	411.0	704.8	12.5	66.7	16
450	914	161.9	6.4	533	-	597	-	-	457.2	-	327	-	276	462.0	774.7	12.5	73.0	16
500	984	178.0	6.4	584	-	641	-	-	508.0	-	356	-	292	514.0	831.8	12.5	79.4	16
600	1168	203.0	6.4	692	-	762	-	-	609.6	-	406	-	330	616.0	990.6	12.5	92.0	16

- 1) All dimensions are in Millimeters
- 2) Flanges except Lap Joint will be furnished with (1.6) Raised Face, which is included in "Thickness(C)" and "Length through Hub(Y)".



## DIMENSIONS OF FORGED FLANGES ANSI B 16.5

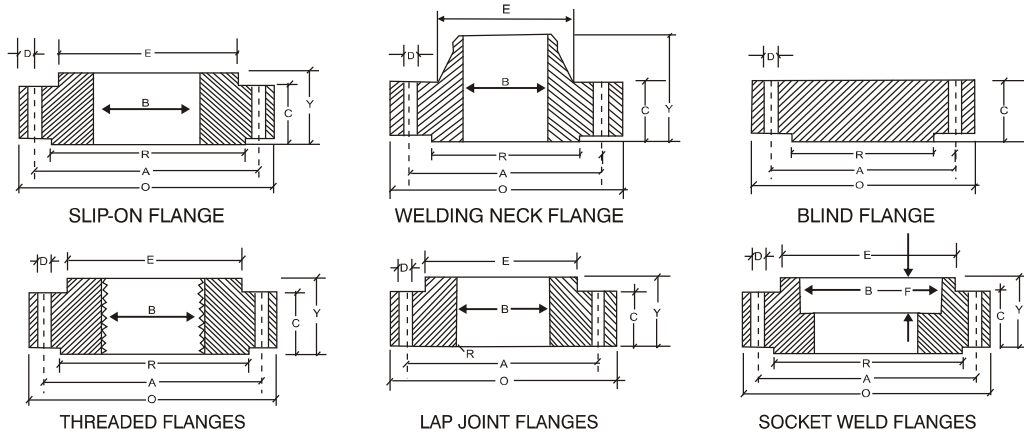

### ASA 1500 CLASS

Nominal Pipe Size	Flange Dia	Dia of Bolt Circle	Dia of Bolt Holes	No. of Holes	Thk of Flange	Dia of Hub	Length Through Hub			Dia of Bore		Dia of R/F	Depth of Socket	Pipe Dia	
							S/O & S/W	W/N	L/J	S/O & S/W	L/J				
(MM)	(INCH.)	O	A	D	C	E	Y	Y	Y	B	B	R	F	X	
For Dimensions from 1/2" to 2 1/2" kindly refer ASA 900 LBS Table.															
80	3	266.7	203.2	31.7	8	47.6	133.3	73.0	117.5	73.0	90.7	91.4	127.0	-	88.90
100	4	311.1	241.3	34.9	8	54.0	161.9	90.5	123.0	90.4	116.1	116.8	157.2	-	114.30
125	5	374.6	292.1	41.3	8	73.0	196.8	104.8	155.6	104.8	143.8	144.5	185.7	-	141.30
150	6	393.7	317.5	38.1	12	82.6	228.6	119.1	171.4	119.1	170.7	171.4	215.9	-	168.27
200	8	482.6	393.7	44.4	12	92.1	292.1	142.9	212.7	142.8	221.5	222.2	269.9	-	219.07
250	10	584.2	482.6	50.8	12	107.9	368.3	158.7	254.0	177.8	276.3	277.3	323.8	-	273.05
300	12	673.1	571.5	54.0	16	123.8	450.8	181.0	282.5	218.9	327.1	328.1	381.0	-	323.85

All Dimensions are in Millimeters • Flanges except Lap Joint will be furnished with(6.35mm) Raised Face, which is not included in Thickness(C) and Length through Hub(Y).

### ASA 2500 CLASS

Nominal Pipe Size	Flange Dia	Dia of Bolt Circle	Dia of Bolt Holes	No. of Holes	Thk of Flange	Dia of Hub	Length Through Hub			Dia of Bore		Dia of R/F	Depth of Socket	Pipe Dia	
							S/O & S/W	W/N	L/J	S/O & S/W	L/J				
(MM)	(INCH.)	O	A	D	C	E	Y	Y	Y	B	B	R	F	X	
15	1/2	133.3	88.9	22.2	4	30.2	42.9	39.7	73.0	39.7	22.3	22.3	34.9	-	21.33
20	3/4	139.7	95.3	22.2	4	31.7	50.8	42.9	79.4	42.9	27.7	27.7	42.9	-	26.67
25	1	158.7	107.9	25.4	4	34.9	57.1	47.7	88.9	47.7	34.5	34.5	50.8	-	33.40
32	1 1/4	184.1	130.2	28.6	4	38.1	73.0	52.4	95.2	52.4	43.2	43.2	63.5	-	42.16
40	1 1/2	203.2	146.0	31.7	4	44.4	79.4	60.3	111.1	60.3	49.5	49.5	73.0	-	48.26
50	2	234.9	171.4	28.6	8	50.8	95.2	69.8	127.0	69.8	62.4	62.0	92.1	-	60.31
65	2 1/2	266.7	196.8	31.7	8	57.1	114.3	79.4	142.9	79.4	74.7	74.7	104.8	-	73.02
80	3	304.8	228.6	34.9	8	66.7	133.3	92.1	168.3	92.1	90.7	90.7	127.0	-	88.90
100	4	355.6	273.0	41.2	8	76.2	165.1	107.9	190.5	107.9	116.1	116.1	157.2	-	114.30
125	5	419.1	323.8	47.6	8	92.1	203.2	130.0	228.6	130.0	143.8	143.8	185.7	-	141.30
150	6	482.6	368.3	54.0	8	107.9	234.9	152.4	273.0	152.4	170.7	170.7	215.9	-	168.27
200	8	552.4	438.1	54.0	12	127.0	304.8	177.8	317.5	177.8	221.5	221.5	269.9	-	129.07
250	10	673.1	539.7	66.7	12	165.1	374.6	228.6	419.1	228.6	276.3	276.3	323.8	-	273.05
300	12	762.0	619.1	73.0	12	184.1	441.3	254.0	463.5	254.0	327.1	327.1	381.0	-	323.85

All Dimensions are in Millimeters • Flanges except Lap Joint will be furnished with(6.35mm) Raised Face, which is not included in Thickness(C) and Length through Hub(Y).



**ASME B16.5-2009**

**TABLE 6 REDUCING THREADED AND SLIP-ON PIPE FLANGES FOR CLASSES 150 THROUGH 2500**

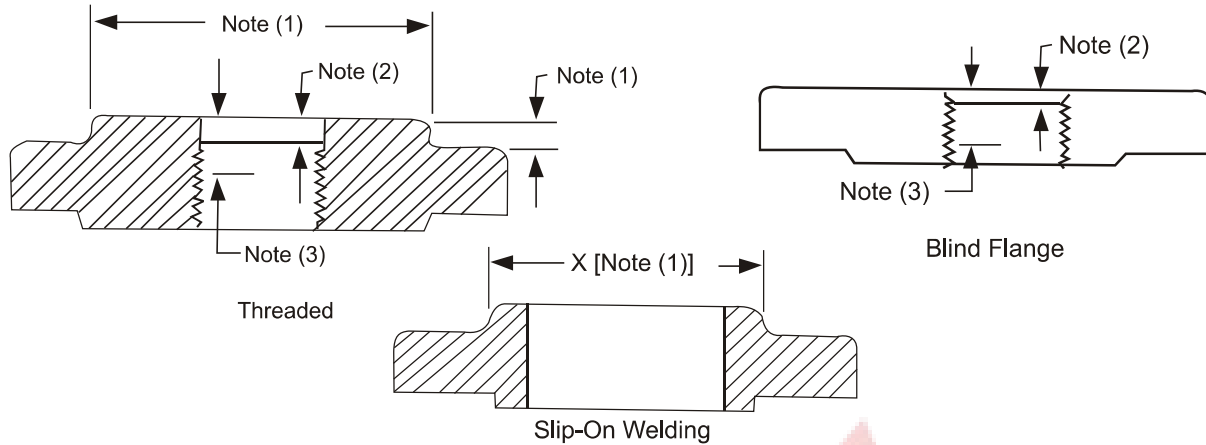

1	2	3	4	5	6
Nominal Pipe Size [Note (4)]	Smallest Size of Reducing Outlet Requiring Hub Flanges {Note (1)}	Nominal Pipe Size [Note (4)]	Smallest Size of Reducing Outlet Requiring Hub Flanges {Note (1)}	Nominal Pipe Size [Note (4)]	Smallest Size of Reducing Outlet Requiring Hub Flanges {Note (1)}
NPS	NPS	NPS	NPS	NPS	NPS
1	1/2	3 1/2	1 1/2	12	3 1/2
1 1/4	1/2	4	1 1/2	14	3 1/2
1 1/2	1/2	5	1 1/2	16	4
2	1	6	2 1/2	18	4
2 1/2	1 1/4	8	3	20	4
3	1 1/4	10	3 1/2	24	4

**NOTES:**

- (1) The hub dimensions shall be at least as large as those of the standard flanges of the sizes to which the reduction is being machined, except flanges reducing to a size smaller than those of Columns 2, 4, and 6 may be made from blind flanges (see Example).
- (2) Class 150 flanges do not have a counterbore. Class 300 and higher pressure flanges will have depth of counterbore Q of 7 mm for NPS 2 and smaller tapping and 9.50 mm for NPS 2 1/2 and larger. The diameter Q of counterbore is the same as that given in the tables of threaded flanges for the corresponding tapping.
- (3) Minimum length of effective threads shall be at least equal dimension T of the corresponding pressure class threaded flange as shown in tables but does not necessarily extend for the face the flange.
- (4) For method of designating reducing threaded and reducing slip-on flanges, and Examples Below.

**EXAMPLES :**

- (1) The size designation is NPS 6 X 2 1/2 - 300 reducing threaded flange. This flange has the following dimensions:  
 NPS 2 1/2 = taper pipe thread tapping (ASME B1.201)  
 320 mm = diameter of regular NPS 6 Class 300 threaded flange  
 35 mm = thickness of regular NPS 6 Class 300 threaded flange  
 178 mm = diameter of hub for regular NPS 5 Class 300 threaded flange. Hub diameter may be one size small to reduce machining, in this example, a hub diameter of NPS 2 1/2 would be the smallest acceptable.  
 15.5 mm = height of hub for regular NPS 5 Class 300 threaded flange
- (2) The size designation is NPS 6 X 2 - Class 300 reducing threaded flange. Use regular NPS 6 Class 300 blind flange tapped with NPS 2 taper pipe thread (ASME B1.20.1)



## CLASS 150 FLANGES SERIES 'A'

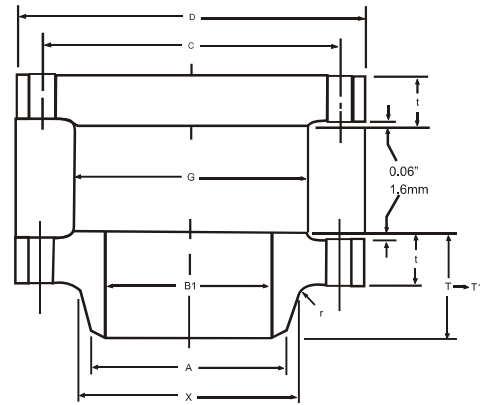

## MSS SP44 FORGED FLANGES

Unit:mm

Nominal Pipe Size	Outside Diam	O.D. of Raised Face	Diam at Base of Hub	Thick-ness	BORE		Length Thru Hub	Diam. of Hub of Bevel	Radius of Base of Hub	DRILLING			Approximate Weight (kg)	
					Wall Thickness					Bolt Circle Diam	Number of Holes	Diam. Of Holes	WN	BL
					9.5mm	12.7mm								
D	G	X	t	B1		T1	A	r	C					
12	483	381.0	365.3	31.8	304.8	298.5	114.3	323.9	9.7	431.8	12	25.4	-	-
14	533	412.8	400.1	35.1	336.6	330.2	127.0	355.6	9.7	476.3	12	28.4	-	-
16	597	469.9	457.2	36.6	387.4	381.0	127.0	406.4	9.7	539.8	16	28.4	-	-
18	635	533.4	505.0	39.6	438.2	431.8	139.7	457.2	9.7	577.9	16	31.8	-	-
20	699	584.2	558.8	42.9	489.0	482.6	144.5	508.2	9.7	635.0	20	31.8	-	-
22	749	641.4	609.6	46.0	539.8	533.4	149.4	558.8	9.7	692.2	20	35.1	-	-
24	813	692.2	663.4	47.8	590.6	584.2	152.4	609.6	9.7	749.3	20	35.1	-	-
26	870	749.3	676.1	68.3	641.4	635.0	120.7		9.7	806.5	24	35.1	147	306
28	927	800.1	726.9	71.4	692.2	685.8	125.5		11.2	863.6	28	35.1	165	363
30	984	857.3	781.1	74.7	743.0	736.6	136.7		11.2	914.4	28	35.1	193	430
32	1060	914.4	831.9	80.8	793.8	787.4	144.5		11.2	977.9	28	41.1	243	537
34	1111	965.2	882.7	82.6	844.6	838.2	149.4		12.7	1028.7	32	41.1	258	600
36	1168	1022.4	933.5	90.4	895.4	889.0	157.0		12.7	1085.9	32	41.1	306	730
38	1238	1073.2	990.6	87.4	946.2	939.8	157.2		12.7	1149.4	32	41.1	342	794
40	1289	1124.0	1041.4	90.4	997.0	990.6	163.6		12.7	1200.2	36	41.1	368	893
42	1346	1193.8	1092.2	96.8	1047.8	1041.4	171.5		12.7	1257.3	36	41.1	422	1044
44	1403	1244.6	1143.0	101.6	1098.6	1092.2	177.8		12.7	1314.5	40	41.1	470	1190
46	1454	1295.4	1196.8	103.1	1149.4	1143.0	185.7		12.7	1365.3	40	41.1	503	1299
48	1511	1358.9	1247.6	108.0	1200.2	1193.8	192.0		12.7	1422.4	44	41.1	556	1470
50	1568	1409.7	1301.8	111.3	1251.0	1244.6	203.2		12.7	1479.6	44	47.8	598	1616
52	1626	1460.5	1352.6	115.8	1301.8	1295.4	209.6		12.7	1536.7	44	47.8	661	1817
54	1683	1511.3	1403.4	120.7	1352.6	1346.2	215.9		12.7	1593.9	44	47.8	730	2031
56	1746	1574.8	1457.5	124.0	1403.4	1397.0	228.6		12.7	1651.0	48	47.8	813	2244
58	1803	1625.6	1508.3	128.5	1454.2	1447.8	235.0		12.7	1708.2	48	47.8	890	2491
60	1854	1676.4	1559.1	131.8	1505.0	1498.6	239.8		12.7	1759.0	52	47.8	936	2697

To specified by purchaser

- Class 150 flanges will be furnished with 0.06" (1.6mm) raised face, which is included 'Thickness' (t) and 'Length through Hub' (T1)
- Dimensional tolerance are in accordance with ANSI B16.5



## CLASS 300 FLANGES SERIES 'A'

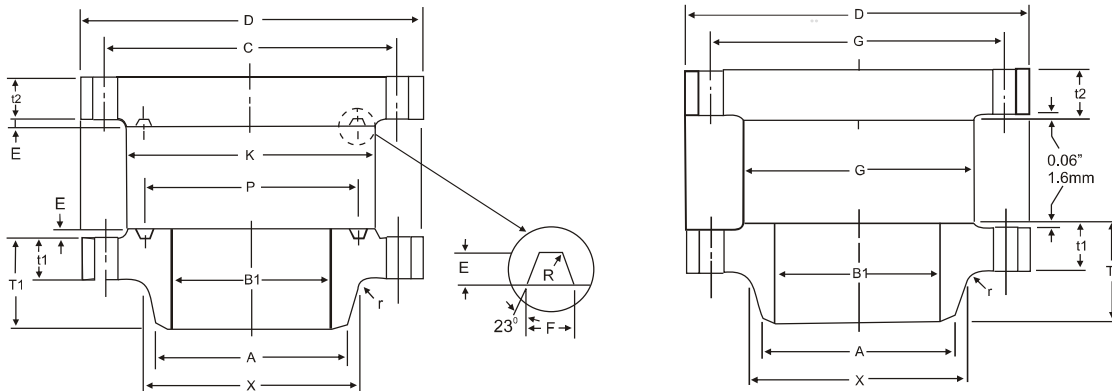

## MSS SP44 FORGED FLANGES

Unit:mm

Nominal Pipe Size	Outside Diam	O. D. of Raised Face	Diam At Base of Hub	Thickness		BORE		Length Thru Hub	Diam of Hub of Bevel	Radius of Fillet	DRILLING			Approximate Weight (kg) 9.5mm	
				Welding Neck	Blind	9.5mm	12.7mm				Bolt Circle Diam	Number of Holes	Diam Of Holes	WN	BL
12	521	381	347.7	50.8	50.8	304.8	298.5	130.0	323.9	9.7	450.9	16	31.8	-	-
14	584	412.8	425.5	53.8	53.8	336.6	330.2	142.7	355.6	9.7	514.4	20	31.8	-	-
16	648	469.9	482.6	57.2	57.2	387.4	381.0	146.1	406.4	9.7	571.5	20	35.1	-	-
18	711	533.4	533.4	60.5	60.5	468.2	431.8	158.8	457.2	9.7	628.7	24	35.1	-	-
20	775	584.2	587.2	63.5	63.5	489.0	482.6	162.1	508.0	9.7	685.8	24	35.1	-	-
22	838	641.4	641.4	66.5	66.5	539.8	533.4	165.1	558.8	9.7	743.0	24	41.1	-	-
24	914	692.2	701.5	69.9	69.9	590.6	584.2	168.1	609.6	9.7	812.8	24	41.1	-	-
26	972	749.3	720.9	79.2	84.1	641.4	635.0	184.2	660.4	9.7	876.3	28	44.5	275	460
28	1035	800.1	774.7	85.9	90.4	692.2	685.8	196.9	711.2	11.2	939.8	28	44.5	340	566
30	1092	857.3	827.0	91.9	95.3	743.0	736.6	209.6	762.0	11.2	997.0	28	47.8	389	663
32	1149	914.4	881.1	98.6	100.1	793.8	787.4	222.3	812.8	11.2	1054.1	28	50.8	445	770
34	1207	965.2	936.8	101.6	104.6	844.6	838.2	231.6	863.6	12.7	1104.9	28	50.8	498	894
36	1270	1022.4	990.6	104.6	111.3	895.4	889.0	241.3	914.4	12.7	1168.4	32	53.8	563	1040
38	1168	1028.7	993.6	108.0	108.0	946.2	939.8	180.8	-	12.7	1092.2	32	41.1	307	872
40	1238	1085.9	1047.8	114.3	114.3	997.0	990.6	193.5	-	12.7	1155.7	32	44.5	392	1035
42	1289	1136.7	1098.6	119.1	119.1	1047.8	1041.4	200.2	-	12.7	1206.5	32	44.5	409	1173
44	1353	1193.8	1149.4	124.0	124.0	1198.6	1092.2	206.2	-	12.7	1263.7	32	47.8	464	1340
46	1416	1244.6	1203.5	128.5	128.5	1149.4	1143.0	215.9	-	12.7	1320.8	28	50.8	544	1600
48	1467	1301.8	1254.3	133.4	133.4	1200.2	1193.8	223.8	-	12.7	1371.6	32	50.8	569	1700
50	1530	1358.9	1305.1	139.7	139.7	1251.0	1244.6	231.6	-	12.7	1428.8	32	53.8	645	1936
52	1581	1409.7	1355.9	144.5	144.5	1301.8	1295.4	238.3	-	12.7	1479.6	32	53.8	694	2143
54	1657	1466.9	1409.7	152.4	152.4	1352.6	1346.2	252.5	-	12.7	1549.4	28	60.5	834	2486
56	1708	1517.7	1463.5	153.9	153.9	1403.4	1397.0	260.4	-	12.7	1600.2	28	60.5	882	2674
58	1759	1574.8	1514.3	158.8	158.8	1454.2	1447.8	266.7	-	12.7	1651.0	32	60.5	928	2913
60	1810	1625.6	1565.1	163.6	163.6	1505.0	1498.6	273.0	-	12.7	1701.8	32	60.5	989	3184

- Class 300 flanges will be furnished with 0,06" (1.6mm) raised face, which is included in 'Thickness' (t) and 'Length through Hub' (T1)
- Dimensional tolerances are in accordance with ANSI B 16.5





## CLASS 600 FLANGES SERIES A

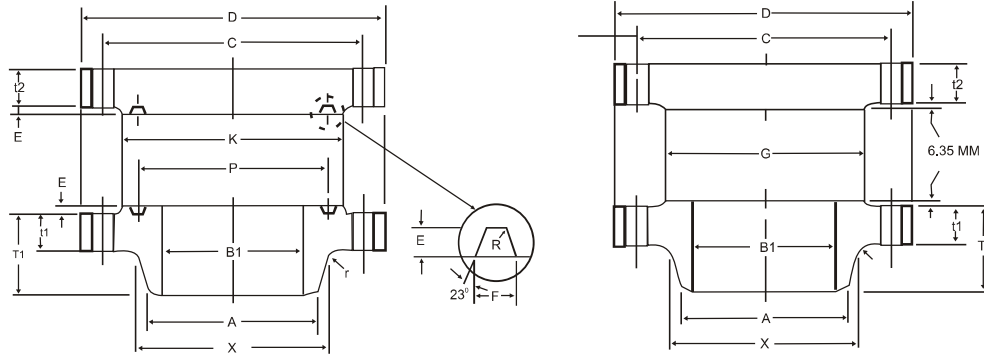

## MSS SP44 FORGED FLANGES

Unit : mm

Nominal Pipe Size	Outside Diam	O.D. Of Raised Face	Diam. At Base of Hub	Thickness		BORE		Length Thru Hub	Diam. Of Hub of Bevel	Radius of Fillet	DRILLING			Approximate Weight (Kg)	
				Welding Neck	Blind	9.5 mm	12.7 mm				Bolt Circle Diam.	Number of Holes	Diam. Of Holes	WN	BL
12	558.8	381.0	400.1	66.5	66.5	304.8	298.5	155.4	323.9	11.2	489.0	20	35.1	-	-
14	602.0	412.8	431.8	69.9	69.9	336.9	330.2	165.1	355.6	11.2	527.1	20	38.1	-	-
16	685.8	469.9	495.3	76.2	76.2	687.4	381.0	177.8	406.4	11.2	603.3	20	41.1	-	-
18	743.0	533.4	546.1	82.6	82.6	438.2	431.8	184.2	457.2	11.2	654.1	20	44.5	-	-
20	812.8	584.2	609.6	88.9	88.9	488.9	482.6	190.5	508.0	11.2	723.9	24	44.5	-	-
22	870.0	641.4	666.8	95.3	95.3	539.8	533.4	196.9	558.8	11.2	777.7	24	47.8	-	-
24	939.8	692.2	717.6	101.6	101.6	590.6	584.2	203.2	609.6	11.2	838.2	24	50.8	-	-
26	1016.0	749.3	747.8	108.0	125.5	641.4	635.0	222.25	660.4	12.7	914.4	28	50.8	431	765
28	1073.2	800.1	803.2	111.3	131.8	692.2	685.8	234.95	744.2	12.7	965.2	28	53.8	484	896
30	1130.3	857.3	826.1	114.3	139.7	743.0	736.6	247.65	762.0	12.7	1022.4	28	53.8	550	1060
32	1193.8	914.4	917.5	117.4	147.6	793.8	787.4	260.35	812.8	12.7	1079.5	28	60.5	614	1237
34	1244.6	965.2	973.1	120.7	153.9	844.6	838.2	269.75	863.6	14.2	1130.3	28	60.5	675	1410
36	1314.5	1022.4	1031.8	124.0	162.1	895.4	889.0	282.45	914.4	14.2	1193.8	28	66.5	764	1645
38	1270.0	1054.1	1022.4	152.4	155.5	946.2	939.8	254.00		14.2	1162.1	28	60.5	645	1492
40	1320.8	1111.3	1073.2	158.8	162.1	997.0	990.6	263.65		14.2	1212.9	32	60.5	693	1676
42	1403.4	1168.4	1127.3	168.2	171.5	1047.8	1041.4	279.40		14.2	1282.7	28	66.5	858	2006
44	1454.2	1225.6	1181.1	173.0	177.8	1098.6	1092.2	289.05		14.2	1333.5	32	66.5	911	2223
46	1511.3	1276.4	1235.0	179.3	185.7	1149.4	1143.0	299.97		14.2	1390.7	32	66.5	1019	2518
48	1593.9	1333.5	1289.1	189.0	195.0	1200.2	1193.8	315.98		14.2	1460.5	32	73.2	1200	2925
50	1670.1	1384.3	1343.2	196.9	203.2	1251.1	1244.6	328.68		14.2	1524.1	28	79.2	1403	3351
52	1720.9	1435.1	1394.0	203.2	209.6	1301.8	1295.4	336.55		14.2	1574.8	32	79.2	1473	3650
54	1778.0	1492.3	1447.8	209.6	217.4	1352.6	1346.2	349.25		14.2	1632.0	32	79.2	1616	4050
56	1854.2	1543.1	1501.7	217.4	225.6	1403.4	1397.0	361.95		15.8	1695.5	32	85.9	1820	4550
58	1905.0	1600.2	1552.5	222.3	231.7	1454.2	1447.8	369.82		15.8	1746.3	32	85.9	1929	4950
60	1993.9	1657.4	1609.9	233.4	242.8	1505.0	1498.6	388.87		17.5	1822.5	28	91.9	2325	5709

- Class 600 flanges will be furnished with 0.25" (6.35mm) raised face, which is included in 'Thickness' (t) and 'Length through Hub' (T<sub>1</sub>)
- Dimensional tolerances are in accordance with ANSI B16.5



## FLANGES API 605 ANSI ASME B 16.47 SERIES B FLANGES (API 605)

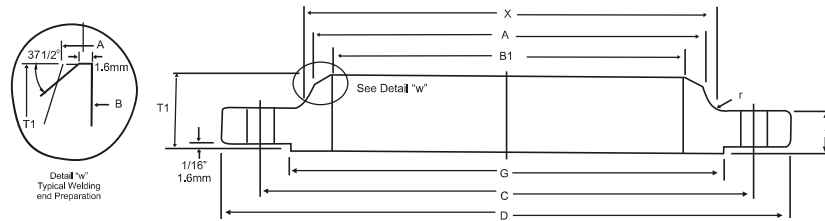

### Class 75 Flanges

Unit:mm

Nominal Pipe Size	Outside Diam. D	O. D. of Raised Face G	Diam at Base of Hub X	Thick-ness t	BORE			Length Thru Hub T1	Diam of Hub of Bevel A	Radius of Base of Hub r	Bolt Circle Diam C	DRILLING		Approximate Weight (kg) 9.5mm wn
					Wall Thickness							Number of Holes	Diam of Holes	
					6.35mm	9.5mm	12.7mm							
26	762	704.9	676.1	33.3	647.7	641.4	635.0	58.7	661.9	7.9	723.9	36	19.1	29.01
28	813	755.7	726.9	33.3	698.5	692.2	685.8	62.0	712.7	7.9	774.7	40	19.1	31.01
30	864	806.5	777.7	33.3	749.3	743.0	736.6	65.0	763.5	7.9	825.5	44	19.1	35.06
32	914	857.3	828.5	35.1	800.1	793.8	787.4	69.9	814.3	7.9	876.3	48	19.1	48.03
34	965	908.1	879.3	35.1	850.9	844.6	838.2	73.2	865.1	7.9	927.1	52	19.1	50.03
36	1034	965.2	935.0	36.6	850.9	895.4	889.0	85.9	915.9	9.7	992.1	40	22.4	62.06
38	1084	1016.0	985.8	38.1	952.5	946.2	939.8	88.9	966.7	9.7	1042.9	40	22.4	70.05
40	1135	1066.8	1036.6	38.1	1003.3	997.0	990.6	91.9	1017.5	9.7	1093.7	44	22.4	74.05
42	1186	1117.6	1087.4	39.6	1054.1	1047.8	1041.4	95.3	1068.3	9.7	1144.5	48	22.4	77.09
44	1251	1174.8	1140.0	42.9	1104.9	1049.4	1143.0	104.6	1119.1	9.7	1203.5	36	25.4	82.08
46	1302	1225.6	1190.8	44.5	1155.7	1149.4	1143.0	108.0	1169.9	9.7	1254.3	40	25.4	105.01
48	1353	1276.4	1241.6	46.0	1206.5	1200.2	1193.8	111.3	1220.7	9.7	1305.1	44	25.4	120.03
50	1403	1327.2	1293.9	47.8	1257.3	1251.0	1244.6	115.8	1271.5	9.7	1355.9	44	25.4	134.28
52	1457	1378.0	1344.7	47.8	1301.8	1301.8	1295.4	120.7	1322.3	9.7	1409.7	48	25.4	142.18
54	1508	1428.8	1397.0	49.3	1358.9	1352.6	1346.2	125.5	1373.1	9.7	1460.6	48	25.4	180.15
56	1575	1485.9	1450.8	50.8	1409.7	1403.4	1397.0	134.9	1423.9	11.2	1521.0	40	28.4	184.58
58	1626	1536.7	1501.6	52.3	1460.5	1454.2	1447.8	138.2	1474.7	11.2	1571.8	44	28.4	195.56
60	1676	1587.5	1552.4	55.6	1511.3	1505.0	1498.6	144.5	1525.5	11.2	1622.6	44	28.4	210.20

### Class 150 Flanges

Unit:mm

Nominal Pipe Size	Outside Diam. D	O. D. of Raised Face G	Diam at Base of Hub X	Thick-ness		BORE			Length Thru Hub T1	Diam of Hub of Bevel A	Radius of Base of Hub r	Bolt Circle Diam C	DRILLING		Approximate Weight (kg) 9.5mm	
				t	(BL)	6.35mm	9.5mm	12.7mm					Number of Holes	Diam of Holes	WN	BL
							B1									
26	786	711.2	684.3	41.1	44.5	647.7	641.4	635.0	88.9	661.9	9.7	744.5	36	22.4	59	165
28	837	762.0	735.1	44.5	47.8	698.5	692.2	685.8	95.3	712.7	9.7	795.3	40	22.4	68	201
30	887	812.8	787.4	44.5	50.8	749.3	743.0	736.6	100.1	763.5	9.7	846.1	44	22.4	74	241
32	941	863.6	839.7	46.0	53.8	800.1	793.8	787.4	108.0	814.3	9.7	900.1	48	22.4	85	288
34	1005	920.8	892.0	49.3	57.2	850.9	844.6	838.2	110.2	865.1	9.7	957.3	40	25.4	103	349
36	1057	971.6	944.6	52.3	58.7	901.7	895.4	889.0	117.3	915.9	9.7	1009.7	44	25.4	117	397
38	1124	1022.4	997.0	53.8	63.5	952.5	946.2	939.8	124.0	968.2	9.7	1069.9	40	28.4	140	485
40	1175	1079.5	1049.3	55.6	66.5	1003.3	997.0	990.6	128.5	1019.0	9.7	1120.6	44	28.4	153	556
42	1226	1130.3	1101.9	58.7	68.3	1054.1	1047.8	1041.4	133.4	1069.8	11.2	1171.4	48	28.4	168	621
44	1276	1181.1	1152.7	60.5	71.4	1104.9	1098.6	1092.2	136.7	1120.6	11.2	1222.2	52	31.8	200	704
46	1341	1234.9	1205.0	62.0	74.7	1155.7	1149.4	1143.0	144.5	1171.4	11.2	1284.2	40	31.8	210	816
48	1392	1289.1	1257.3	65.0	77.7	1206.5	1200.2	1198.8	149.4	1222.2	11.2	1335.0	44	31.8	240	915
50	1443	1339.9	1308.1	68.3	80.8	1257.3	1251.0	1244.6	153.9	1273.0	11.2	1385.8	48	31.8	250	1021
52	1494	1390.7	1360.4	69.9	84.1	1308.1	1301.8	1295.4	157.2	1323.8	11.2	1436.6	52	31.8	266	1139
54	1549	1441.5	1412.7	71.4	87.4	1358.9	1352.6	1346.2	162.1	1374.6	11.2	1492.3	56	31.8	310	1274
56	1600	1492.3	1465.8	73.2	90.4	1409.7	1403.4	1397.0	166.6	1425.4	14.2	1543.1	60	31.8	306	1406
58	1675	1543.1	1516.1	74.7	93.5	1460.5	1454.2	1447.8	174.8	1476.2	14.2	1611.4	48	35.1	367	1596
60	1726	1600.2	1570.0	76.2	96.8	1511.3	1505.0	1498.6	179.3	1527.0	14.2	1662.2	52	35.1	410	1754

BORE (B1) of flanges is shall be specified by th the purchaser.

Class 75 flanges will ne furnished with 0.06" (1.6mm) raised face, which is included in 'Thickness' (t) and Length through hub' T1)



## ANSI ASME B 16.47 CLASS 300 FLANGES SERIES B

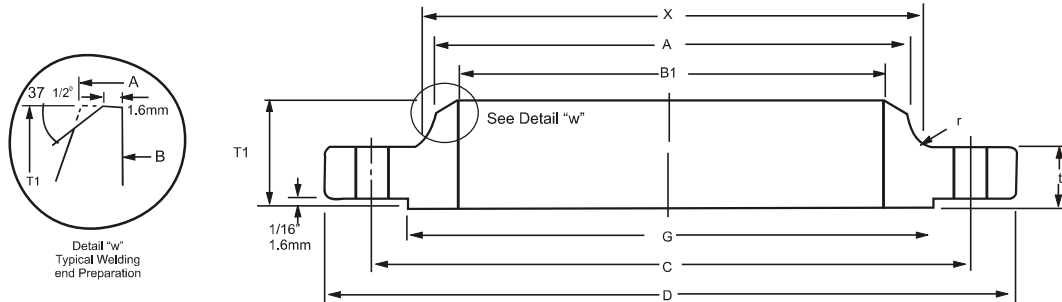

Unit : mm

Nominal Pipe Size	Outside Diam	O.D. of Raised Face	Diam. of Base of Hubs	Diam. of Hub of Bevel	BORE			Length Thru Hub	Thick-ness		Radius of Base of Hub	DRILLING			Approximate Weight (Kg)			
					Wall Thickness				T1	t		(BL)	r	C	Number of Holes	Diam of Holes	WN	BL
					6.35 mm	9.5 mm	12.7 mm											
26	867	736.6	701.5	665.2	647.7	641.4	635.0	144.5	88.9	88.9	14.2	803.1	32	35.1	200	393		
28	921	787.4	755.7	716.0	698.5	692.2	685.8	149.4	88.9	88.9	14.2	857.3	36	35.1	210	443		
30	991	844.6	812.8	768.4	749.3	743.0	736.6	158.0	93.7	93.7	14.2	920.8	36	38.1	270	540		
32	1054	901.7	863.6	819.2	800.1	793.8	787.4	168.1	103.1	103.1	15.7	977.9	32	41.1	330	677		
34	1108	952.5	917.4	870.0	850.9	844.6	838.2	173.0	103.1	103.1	15.7	1031.7	36	41.1	360	747		
36	1171	1009.7	965.2	920.8	901.7	895.4	889.0	180.8	103.1	103.1	15.7	1089.2	32	44.5	410	838		
38	1222	1060.5	1016.0	971.6	952.5	946.2	939.8	192.0	111.3	111.3	15.7	1140.0	36	44.5	571	983		
40	1273	1114.6	1066.8	1022.4	1003.3	997.0	990.6	198.4	115.8	115.8	15.7	1190.8	40	44.5	661	1110		
42	1334	1168.4	1117.6	1074.7	1054.1	1047.8	1041.4	204.7	119.1	119.1	15.7	1244.6	36	47.8	721	1256		
44	1384	1219.2	1173.2	1125.5	1104.9	1098.6	1092.2	214.4	127.0	127.0	15.7	1295.4	40	47.8	801	1441		
46	1461	1270.0	1228.8	1176.3	1155.7	1149.4	1143.0	222.3	128.5	130.0	15.7	1365.3	36	50.8	971	1649		
48	1511	1327.2	1277.9	1227.1	1206.5	1200.2	1193.8	223.8	128.5	134.9	15.7	1416.1	40	50.8	991	1829		
50	1562	1378.0	1330.5	1277.9	1257.3	1251.0	1244.6	235.0	138.2	139.7	15.7	1466.9	44	50.8	1048	2021		
52	1613	1428.8	1382.8	1328.7	1308.1	1301.8	1295.4	242.8	142.7	144.3	15.7	1517.1	48	50.8	1114	2223		
54	1673	1479.6	1435.1	1379.5	1358.9	1352.6	1346.2	239.8	136.7	149.4	15.7	1577.8	48	50.8	1161	2486		
56	1765	1536.7	1493.8	1422.4	1409.7	1403.4	1397.0	268.2	153.9	157.0	17.5	1651.0	36	60.5	1336	2913		
58	1827	1593.9	1547.9	1481.1	1460.5	1454.2	1447.8	274.6	153.9	162.1	17.5	1712.0	40	60.5	1428	3218		
60	1878	1651.0	1598.7	1531.9	1511.3	1505.0	1498.6	271.5	150.9	166.6	17.5	1763.8	40	60.5	1451	3504		

### Notes

1. Bore (B1) OF Flanges is shall be specified by the purchaser.
2. Class 300 Flanges will be furnished with 0.06\* (1.6mm) raised face, which is included in 'Thickness' (t) and 'Length through Hub'T1)



## ANSI ASME B 16.47 CLASS 600 FLANGES SERIES B

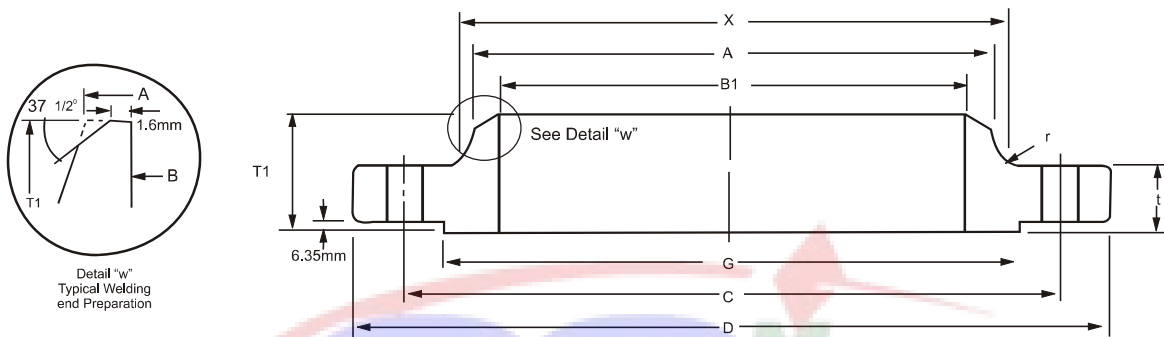

Unit : mm

Nominal Pipe Size	Outside Diam D	O.D. of Raised Face G	Diam. of Base of Hubs X	Diam. of Hub of Bevel A	BORE			Length Thru Hub T1	THICK-NESS		Radius of Base of Hub r	DRILLING			Approximate Weight (Kg) 9.5 mm	
					Wall Thickness				Blind T	Weld Neck (t)		Bolt Circle Diam. C	Number of Holes	Diam of Holes	WN	BL
					6.35 mm	9.5 mm	12.7 mm									
						B1										
26.0	889.0	726.9	698.5	660.4	647.7	641.4	635.0	180.8	111.3	111.3	14.2	806.5	28	44.5	250	543
28.0	952.5	784.4	752.3	711.2	698.5	692.2	685.8	190.5	115.8	115.8	14.2	863.6	28	47.8	295	819
30.0	1022.4	841.2	806.5	762.0	749.3	743.0	736.6	204.7	127.0	125.5	14.2	927.1	28	50.8	368	819
32.0	1085.9	895.4	860.6	812.8	800.1	793.8	787.4	215.9	134.9	130.0	15.7	984.3	28	53.8	431	981
34.0	1162.1	952.5	914.4	863.6	850.9	844.6	838.2	233.4	144.3	141.2	15.7	1054.1	24	60.5	548	1202
36.0	1212.9	1009.7	968.2	914.4	901.7	895.4	889.0	242.8	150.9	146.1	15.7	1104.9	28	60.5	609	1369
38.0	1270.0	1054.1	1022.4	965.2	952.5	946.2	939.8	254.0	155.4	152.4	15.7	1162.1	28	60.5	668	1547
40.0	1320.8	1111.3	1073.2	1016.0	1003.3	997.0	990.6	263.7	162.1	158.8	15.7	1212.9	32	60.5	741	1744
42.0	1403.4	1168.4	1127.3	1066.8	1054.1	1047.8	1041.4	279.4	171.5	168.1	15.7	1282.7	28	66.5	923	2084
44.0	1454.2	1225.6	1187.1	1117.6	1104.9	1098.6	1062.2	289.1	177.8	173.0	15.7	1333.5	32	66.5	982	2320
46.0	1511.3	1276.4	1234.9	1168.4	1155.7	1143.4	1143.0	300.0	185.7	179.3	15.7	1390.7	32	66.5	982	2617
48.0	1539.9	1333.5	1289.1	1219.2	1206.5	1200.2	1193.8	316.0	195.3	189.0	15.7	1460.5	32	73.2	1298	3062
50.0	1670.1	1384.3	1343.2	1270.0	1257.3	1251.0	1244.6	328.7	203.2	196.9	15.7	1524.0	28	79.2	1514	3498
52.0	1720.9	1435.1	1394.0	1320.8	1308.1	1301.8	1295.4	336.6	209.6	203.2	15.7	1574.8	32	79.2	1618	3830
54.0	1778.0	1492.3	1447.8	1371.6	1358.9	1352.6	1346.2	349.3	217.4	209.6	15.7	1632.0	32	79.2	1782	4242
56.0	1854.2	1543.1	1501.6	1422.4	1409.7	1403.4	1397.0	362.0	225.6	217.4	17.5	1695.5	32	85.9	1945	4786
58.0	1905.0	1600.2	1552.4	1473.2	1460.5	1454.2	1447.8	369.8	231.6	222.3	17.5	1746.3	32	85.9	2109	5188
60.0	1993.9	1657.4	1609.9	1524.0	1511.3	1505.0	1498.6	388.9	242.8	233.4	17.5	1822.5	28	91.9	2273	5958

### Notes

Dimensions for class 600, 900 NPS 36" and larger as the same as for series a flanges



## CLASS 150/300 FLANGES

### Long Welding Neck Flanges

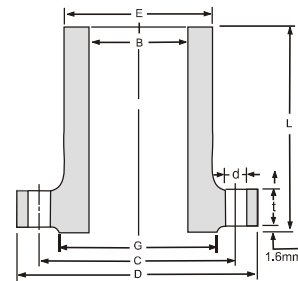

Unit : mm

Nominal Pipe Size	Outside Diameter	O.D. Of Raised Face	Hub Diameter at Bevel	Diameter of Bore	Thickness of Flange Min.	Length Through Hub	DRILLING		
							Diameter of Bolt Circle	Number of Holes	Diameter of Holes
	D	G	E	B	t	L	C		d
1/2	89	35.1	30.2	12.7	11.2	228.6	60.5	4	15.7
3/4	99	42.9	38.1	19.1	12.7	228.6	69.9	4	15.7
1	108	50.8	50.8	25.4	14.2	228.6	79.2	4	15.7
1 1/4	117	63.5	60.5	31.8	15.7	228.6	88.9	4	15.7
1 1/2	127	73.2	66.5	38.1	17.5	228.6	98.6	4	15.7
2	152	91.9	82.6	50.8	19.1	228.6	120.7	4	19.1
2 1/2	178	104.6	95.3	63.5	22.4	228.6	139.7	4	19.1
3	191	127.0	108.0	76.2	23.9	228.6	152.4	4	19.1
3 1/2	216	139.7	124.0	88.9	23.9	228.6	177.8	8	19.1
4	229	157.2	139.7	101.6	23.9	304.8	190.5	8	19.1
5	254	185.7	165.1	127.0	23.9	304.8	215.9	8	22.4
6	279	215.9	196.9	152.4	25.4	304.8	241.3	8	22.4
8	343	269.7	247.7	203.2	28.4	304.8	298.5	8	22.4
10	406	323.9	304.8	254.0	30.2	304.8	362.0	12	25.4
12	483	381.0	365.3	304.8	31.8	304.8	431.8	12	25.4
14	533	412.8	406.4	355.6	35.1	304.8	476.3	12	28.4
16	597	469.9	457.2	406.4	36.6	304.8	539.8	16	28.4
18	635	533.4	508.0	457.2	39.6	304.8	577.9	16	31.8
20	699	584.2	558.3	508.0	42.9	304.8	635.0	20	31.8
24	813	692.2	666.8	609.6	47.8	304.8	749.3	20	35.1

Unit : mm

Nominal Pipe Size	Outside Diameter	O.D. Of Raised Face	Hub Diameter at Bevel	Diameter of Bore	Thickness of Flange Min.	Length Through Hub	DRILLING		
							Diameter of Bolt Circle	Number of Holes	Diameter of Holes
	D	E	G	t	B	L	C		d
1/2	95	38.1	35.1	14.2	12.7	228.6	66.5	4	15.7
3/4	117	47.8	42.9	15.7	19.1	228.6	82.6	4	19.1
1	124	53.8	50.8	17.5	25.4	228.6	88.9	4	19.1
1 1/4	133	63.5	63.5	19.1	31.8	228.6	98.6	4	19.1
1 1/2	155	69.9	73.2	20.6	38.1	228.6	114.3	4	22.4
2	165	84.1	91.9	22.4	50.8	228.6	127.0	8	19.1
2 1/2	191	100.1	104.6	25.4	63.5	228.6	149.4	8	22.4
3	210	117.3	127.0	28.4	76.2	228.6	168.1	8	22.4
3 1/2	229	133.4	139.7	30.2	88.9	228.6	184.2	8	22.4
4	254	146.1	157.2	31.8	101.6	304.8	200.2	8	22.4
5	279	177.8	185.7	35.1	127.0	304.8	235.0	8	22.4
6	318	206.2	215.9	36.6	152.4	304.8	269.7	12	22.4
8	381	260.4	269.7	41.1	203.2	304.8	330.2	12	25.4
10	445	320.5	323.9	47.8	254.0	304.8	387.4	16	28.4
12	521	374.7	381.0	50.8	304.8	304.8	450.9	16	31.8
14	584	425.5	412.8	53.8	355.6	304.8	514.4	20	31.8
16	648	482.6	469.9	57.2	406.2	304.8	571.5	20	35.1
18	711	533.4	533.4	60.5	457.2	304.8	628.7	24	35.1
20	775	587.2	584.2	63.5	508.0	304.8	685.8	24	35.1
24	914	701.5	692.2	69.9	609.6	304.8	812.8	24	41.1

#### Notes

1. Bore (B) is the not same as nominal pipe size
2. Welding necks longer than listed are available in all sizes on special order



## WELDING NECK

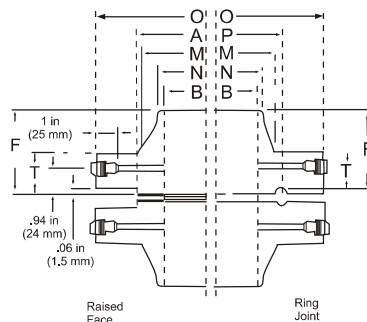

## SLIP-ON

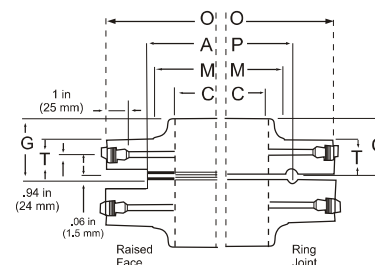

NPS	DN	FLANGE OUTSIDE DIAMETER O	FLANGE THICKNESS		RAISED FACE DIAMETER A	BORE		LENGTH TRU HUB			
			RAISED FACE T	RING JOINT T		WELDING NECK B	SLIP-ON C	WELDING NECK		SLIP-ON AND THREADED	
								RAISED FACE F	RING JOINT F	RAISED FACE G	RING JOINT G
CLASS 300 (PN 50)											
1	25	4.88	1.50	1.25	2.00	1.05	1.36	3.25	3.00	1.88	1.62
1 1/4	32	5.25	1.50	1.25	2.50	1.38	1.70	3.31	3.06	1.81	1.56
1 1/2	40	6.12	1.50	1.25	2.88	1.61	1.95	3.38	3.12	1.88	1.62
2	50	6.50	1.50	1.25	3.62	2.07	2.44	3.38	3.12	1.94	1.69
2 1/2	65	7.50	1.50	1.25	4.12	2.47	2.94	3.50	3.25	2.00	1.75
3	80	8.25	1.50	1.25	5.00	3.07	3.57	3.50	3.25	2.06	1.81
4	100	10.0	1.50	1.25	6.19	4.03	4.57	3.62	3.38	2.12	1.88
5	125	11.0	1.50	1.38	7.31	5.05	5.66	4.00	3.88	2.12	2.00
6	150	12.5	1.50	1.44	8.50	6.07	6.72	3.94	3.88	2.12	2.06
8	200	15.0	1.62	1.62	10.62	7.98	8.72	4.38	4.38	2.44	2.44
10	250	17.5	1.88	1.88	12.75	10.02	10.88	4.62	4.62	2.62	2.62
12	300	20.5	2.00	2.00	15.00	12.00	12.88	5.12	5.12	2.88	2.88
14	350	23.0	2.12	2.12	16.25	13.25	14.14	5.62	5.62	3.00	3.00
16	400	25.5	2.25	2.25	18.50	15.25	16.16	5.75	5.75	3.25	3.25
18	450	28.0	2.38	2.38	21.00	17.25	18.18	6.25	6.25	3.50	3.50
20	500	30.5	2.50	2.50	23.00	19.25	20.20	6.38	6.38	3.75	3.75
24	600	36.0	2.75	2.75	27.25	23.25	24.25	6.62	6.62	4.19	4.19
		915	70.0	70.0	692.20	590.6	616.0	168.3	168.3	106	106.4

# ASME/ANSI B16.36 does not cover Class 300 Threaded Orifice Flanges in sizes above NPS 8 (DN 200).

Not included in ASME/ANSI B16.36

□ 0.06" (1.6mm) Raised Face is included in Flange Thickness T, and length through Hub, F & G.

INCHES
MILLIMETRES

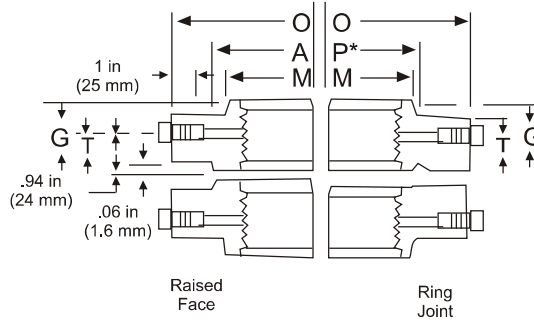

**CLASS 300 (PN 50)  
FORGED  
ORIFICE FLANGES  
ASTM A-105  
ASME/ANSI B 16.36**

NPS	DN	DRILLING			BOLTING			DIAMETER OF HUB		APPROXIMATE WEIGHT			
		NO. OF HOLES	DIA. OF HOLES	DIA. OF BOLT CIRCLE	BOLT DIA. (Inches)	LENGTH		AT BASE M	AT CHAMFER N	WELDING NECK		SLIP-ON-AND THREADED	
						RAISED FACE	RING JOINT			RAISED FACE	RING JOINT	RAISED FACE	RING JOINT
CLASS 300 (PN 50)													
1	25	4	0.69 18	3.50 89	5/8 5/8	4.00 102	4.75 121	2.12 54.0	1.32 33.5	18 9	20 9	15 7	17 7.5
11/4	32	4	0.69 17.5	3.88 99	5/8 5/8	4.00 102	4.75 121	2.50 63.5	1.66 42.2	21 9.5	23 10.5	17 7.5	20 9
11/2	40	4	0.81 18	4.50 114	3/4 3/4	4.25 108	5.00 127	2.75 70	1.90 48.5	28 12.5	30 13.5	24 11	28 13
2	50	8	0.69 18	5.00 127	5/8 5/8	4.00 102	4.75 120	3.31 84	2.38 60.5	33 15	36 16	27 12	31 14
21/2	65	8	0.81 21	5.88 149	3/4 3/4	4.25 108	5.00 127	3.94 100	2.88 73.0	43 19.5	46 21	36 16	42 19
3	80	8	0.81 21	6.62 168	3/4 3/4	4.25 108	5.00 127	4.62 117	3.50 89.0	48 21.5	52 23.5	42 19	48 22
4	100	8	0.81 21	7.88 200	3/4 3/4	4.25 108	5.00 127	5.75 146	4.50 114.0	68 30.5	73 33	60 27	66 30
5	125	8	0.88 23	9.25 235	3/4 3/4	4.25 108	5.50 140	7.00 178	5.56 141.2	78 35	89 40	69 31	80 36
6	150	12	0.88 23	10.62 270	3/4 3/4	4.25 108	5.50 140	8.12 206	6.63 168.0	100 45	115 52	94 42.5	110 50
8	200	12	1.00 26	13.00 330	7/8 7/8	4.50 115	6.00 153	10.25 260	8.63 219.0	155 70	180 81	135 61	160 73
10	250	16	1.12 29	15.25 387	1 1	5.50 140	6.50 165	12.62 321	10.75 273.0	220 99	255 115	200 90	230 104
12	300	16	1.25 32	17.75 451	1 1/8 1 1/8	5.50 140	7.00 178	14.75 375	12.75 324.0	330 149	380 171	280 125	325 147
14	350	20	1.25 32	20.25 514	1 1/8 1 1/8	6.00 153	7.00 178	16.75 425.5	14.00 356.0	425 191	485 218	395 178	450 204
16	400	20	1.38 35	22.50 572	1 1/4 1 1/4	6.50 165	8.00 204	19.00 483	16.00 406.0	590 266	660 297	465 209	535 243
18	450	24	1.38 35	24.75 629	1 1/4 1 1/4	6.50 165	8.00 204	21.00 535	18.0 457.0	750 338	830 374	610 275	690 313
20	500	24	1.38 35	27.00 686	1 1/4 1 1/4	7.00 178	8.00 204	23.12 585	20.00 508.0	910 410	1025 461	740 336	840 381
24	600	24	1.62 42	32.00 813	1 1/2 1 1/2	7.50 191	9.00 229	27.62 700	24.00 610.0	1350 608	1500 675	1125 510	1300 590

POUNDS

KILOGRAMS

The tapped metering holes are drilled as follows

1/2" for NPS 4 (DN 100) and over

3/8" for sizes NPS 3 (DN 80)

1/4" for sizes NPS 1 1/2 (DN 65) and under.



## WELDING NECK

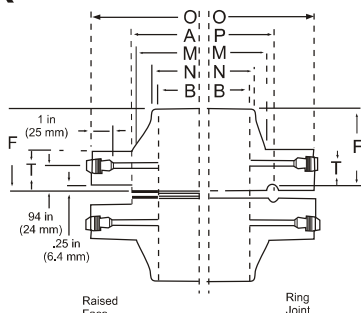

## SLIP-ON

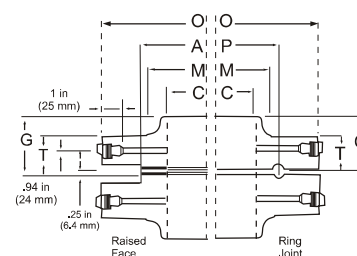

## † CLASS 400 (PN 68)

NPS	DN	FLANGE OUTSIDE DIAMETER	°FLANGE THICKNESS		RAISED FACE DIAMETER	BORE		°LENGTH TRU HUB			
			RAISED FACE	RING JOINT		WELDING NECK	SLIP-ON	WELDING NECK		SLIP-ON AND THREADED	
								F	F	G	G
4	100	10 254	1.38 35.0	1.38 35.0	6.19 157.2	B	C	F	F	G	G
5	125	11 279	1.50 38.5	1.50 38.1	7.31 185.7	As Specified By purchaser	5.66 143.8	4.0 101.6	4 101.6	2.12 54.0	2.12 54.0
6	150	12.5 318	1.62 41.5	1.62 41.5	8.50 215.9		6.72 170.7	4.06 103.2	4.06 103.2	2.25 57.2	2.25 57.2
8	200	15 381	1.88 48.0	1.88 48.0	10.62 269.9		8.72 221.5	4.62 117.5	4.62 117.4	2.69 68.3	2.69 68.3
10	250	17.5 445	2.12 54.0	2.12 54.0	12.75 323.9		10.88 276.4	4.88 123.5	4.88 123.8	2.88 73.0	2.88 73.0
12	300	20.5 520	2.25 57.5	2.25 57.5	15.00 381.0		12.88 327.2	5.38 136.5	5.38 136.5	3.12 79.4	3.12 79.4

## † CLASS 600 (PN 100)

NPS	DN	FLANGE OUTSIDE DIAMETER	°FLANGE THICKNESS		RAISED FACE DIAMETER	BORE		°LENGTH TRU HUB			
			RAISED FACE	RING JOINT		WELDING NECK	SLIP-ON	WELDING NECK		SLIP-ON AND THREADED	
								F	F	G	G
4	100	10.75 273	1.50 38.5	1.50 38.1	6.19 157.2	B	C	F	F	G	G
5	125	13.00 330	1.75 44.5	1.75 44.5	7.31 185.7	As Specified By purchaser	5.66 143.8	4.50 114.3	4.50 114.3	2.38 60.5	2.38 60.5
6	150	14.00 356	1.88 48.0	1.88 48.0	8.50 215.9		6.72 170.7	4.62 117.5	4.62 117.5	2.62 66.7	2.62 66.7
8	200	16.50 419	2.19 56.0	2.19 56.0	10.62 269.9		8.72 221.5	5.25 133.4	5.25 133.4	3.00 76.2	3.00 76.2
10	250	20.00 510	2.50 63.5	2.50 63.5	12.75 323.9		10.88 276.4	6.00 152.4	6.00 152.4	3.38 85.7	3.38 85.7
12	300	22.00 560	2.62 67.0	2.62 67.0	15.00 381.0		12.88 327.2	6.12 155.6	6.12 155.6	3.62 92.1	3.62 92.1

□ .25" (6.4 mm) Raised Faces not included in Flange Thickness T, and Length through Hub F & G.

† Flanges size NPS 3 (DN80) and smaller are identical to Class 300 flanges, except for bolting steel specifications, compliance with which then permits their use for these higher class ratings.

Not covered by ASME/ANSI B16.36

# Welding Neck Orifice Flanges in sizes NPS 14 through 24 (DN 350 through 600), as covered by ASME/ANSI B 16.36, are available upon application.

INCHES  
MILLIMETRES





## THREADED

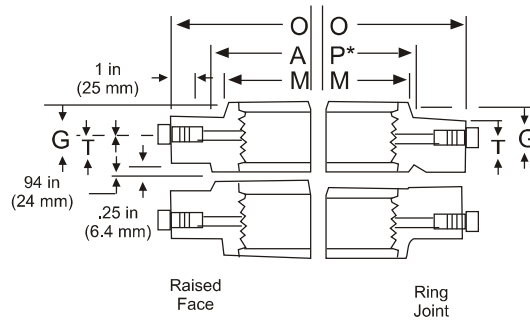

**CLASS 400 (PN 68)**  
**CLASS 600 (PN 100)**  
**FORGED**  
**#ORIFICE FLANGES**  
**ASTM A-105 ASME**  
**ANSI B16.36 ASME**  
**ANSI B 16.36a**

NPS	DN	DRILLING			BOLTING		DIAMETER OF HUB		APPROXIMATE WEIGHT				
		NO. OF HOLES	DIA. OF HOLES	DIA. OF BOLT CIRCLE	BOLT DIA. (Inches)	LENGTH		AT BASE M	AT CHAMFER N	WELDING NECK		SLIP-ON AND SCREWED	
						RAISED FACE	RING JOINT			RAISED FACE	RING JOINT	RAISED FACE	RING JOINT
4	100	8	1	7.88	7/8	5.5	6.0	5.75	4.50	83	92	65	74
		8	26	200.0	7/8	140	153	146.1	114.3	37	41.5	29	33.5
5	125	8	1	9.25	7/8	5.75	6.25	7.0	5.56	99	110	75	85
		8	26	235.0	7/8	146	159	177.8	141.2	45	50	34	38
6	150	12	1	10.62	7/8	6.25	6.5	8.12	6.63	135	145	110	120
		12	26	269.7	7/8	149	165	206.4	168.4	61	65	50	54
8	200	12	1.12	13.0	1	6.75	7.25	10.25	8.63	205	225	165	180
		12	29	330.2	1	172	185	260.4	219.2	90	101	74	81
10	250	16	1.25	15.25	1 1/8	7.5	8.0	12.62	10.75	300	325	235	255
		16	32	387.3	1 1/8	191	204	320.7	273.1	135	146	106	115
12	300	16	1.38	17.75	1 1/4	8.0	8.5	14.75	12.75	420	445	330	355
		16	35	450.8	1 1/4	205	216	374.6	323.8	189	200	149	160

NPS	DN	DRILLING			BOLTING		DIAMETER OF HUB		APPROXIMATE WEIGHT				
		NO. OF HOLES	DIA. OF HOLES	DIA. OF BOLT CIRCLE	BOLT DIA. (Inches)	LENGTH		AT BASE M	AT POINT OF WELDING N	WELDING NECK		SLIP-ON AND SCREWED	
						RAISED FACE	RING JOINT			RAISED FACE	RING JOINT	RAISED FACE	RING JOINT
4	100	8	1.00	8.50	7/8	6.00	6.5	6.00	4.50	97	110	87	98
		8	26	216	7/8	152	165	152	114	44	50	39	44
5	125	8	1.13	10.50	1	5.50	7.00	7.44	5.56	115	170	145	160
		8	29	267	1	140	178	189	141	52	77	66	72
6	150	12	1.13	11.50	1	7.00	7.5	8.75	6.63	195	210	190	205
		12	29	292	1	178	191	222	168	89	95	89	92
8	200	12	1.25	13.75	1 1/8	7.75	8.25	10.75	8.63	285	305	275	295
		12	32	349	1 1/8	197	210	273	219	129	138	125	133
10	250	16	1.38	17.00	1 1/4	8.75	9.25	13.50	10.75	450	485	410	445
		16	35	432	1 1/4	222	235	343	273	204	220	186	200
12	300	20	1.38	19.25	1 1/4	9.00	9.5	15.75	12.75	540	580	490	530
		20	35	489	1 1/4	229	241	400	324	245	263	222	239

The tapped metering holes are drilled as follows:  
 1/2" For size NPS 4 (DN 100) and over.

POUNDS
KILOGRAMS



## WELDING NECK

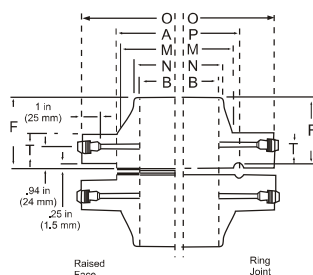

## SLIP-ON

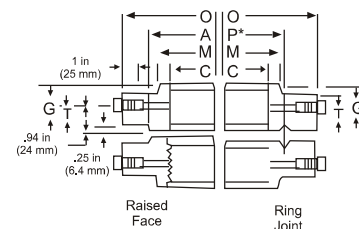

**CLASS 900 (PN 150)** For sizes 2 1/2 and smaller, use Class 1500 (PN 250)

NPS	DN	FLANGE THICKNESS		RAISED FACE DIAMETER	BORE		LENGTH TRU HUB				
		RAISED FACE	RING JOINT		WELDING NECK	SLIP-ON	WELDING NECK		SLIP-ON AND THREADED		
							F	F	G	G	
3	80	9.50	1.50	1.50	5.00	B	C	F	F	G	G
4	100	11.50	1.75	1.75	6.19	As specified	3.57	4.00	4.00	2.12	2.12
5	125	13.75	2.00	2.00	7.31		90.7	101.6	101.6	54.0	54.0
6	150	15.00	2.19	2.19	8.50	by purchaser	4.57	4.50	4.50	2.75	2.75
8	200	18.50	2.50	2.50	10.63		116.1	114.3	114.3	70.0	70.0
10	250	21.50	2.75	2.75	12.75	As specified	5.66	5.00	5.00	3.12	3.12
12	300	24.00	3.12	3.12	15.00		143.8	127.0	127.0	79.4	79.4
						by purchaser	6.72	5.50	5.50	3.38	3.38
							170.7	139.7	139.7	85.7	85.7
						As specified	8.72	6.38	6.38	4.00	4.00
							221.5	161.9	161.9	101.6	101.6
						by purchaser	10.88	7.25	7.25	4.25	4.25
							276.4	184.2	184.2	108.0	108.0
						As specified	12.88	7.88	7.88	4.62	4.62
							327.2	200.0	200.0	117.5	117.5

## CLASS 1500 (PN 250)

NPS	DN	FLANGE THICKNESS		RAISED FACE DIAMETER	BORE		LENGTH TRU HUB				
		RAISED FACE	RING JOINT		WELDING NECK	SLIP-ON	WELDING NECK		SLIP-ON AND THREADED		
							F	F	G	G	
1	25	5.88	1.50	1.50	2.00	B	C	F	F	G	G
1 1/4	32	6.25	1.38	1.38	2.50	As specified	1.36	3.25	3.25	1.88	1.75
1 1/2	40	7.00	1.50	1.50	2.88		34.5	82.55	82.55	47.6	44.5
2	50	8.50	1.50	1.50	3.62	by purchaser	1.70	2.88	2.88	1.88	1.75
2 1/2	65	9.62	1.62	1.62	4.12		43.2	73.15	73.15	47.6	44.5
3	80	10.50	1.88	1.88	5.00	As specified	1.95	3.50	3.50	1.88	1.75
4	100	12.25	2.12	2.12	6.19		49.5	88.90	88.90	47.6	44.5
5	125	14.75	2.88	2.88	7.31	by purchaser	2.44	4.00	4.00	2.25	2.25
6	150	15.50	3.25	3.25	8.50		62.0	101.6	101.6	57.2	57.2
8	200	19.00	3.62	3.62	10.62	As specified	2.94	4.12	4.12	2.50	2.50
10	250	23.00	4.25	4.25	12.75		74.7	104.8	104.8	63.5	63.5
12	300	26.50	4.88	4.88	15.00	by purchaser	3.57	4.62	4.62	2.88	2.88
							90.7	117.5	117.5	73.0	73.0
						As specified	4.57	4.88	4.88	3.56	3.56
							116.1	123.8	123.8	90.5	90.4
						by purchaser	5.66	6.12	6.12	4.12	4.12
							143.8	155.6	155.6	104.8	104.8
						As specified	6.72	6.75	6.75	4.69	4.69
							170.7	171.4	171.4	119.1	119.1
						by purchaser	8.72	8.38	8.38	5.62	5.62
							221.5	212.7	212.7	142.9	142.9
						As specified	10.88	10.00	10.00	6.25	6.25
							276.4	254.0	254.0	158.8	158.8
						by purchaser	12.88	11.12	11.12	7.12	7.12
							327.2	282.6	282.6	181.0	181.0

# Sizes NPS 14 (DN 350) and larger, on application.

† Class 2500 (PN 400) Welding Neck Orifice Flanges, NPS 1 through 12 (DN 25 through 300), as covered by ASME / ANSI B 16.36 are available upon application. Not covered by ASME / ANSI B 16.36

∅0.25" (6.4mm) Raised Face is not included in Flange Thickness T, and Length through Hub F & G.



**THREADED**

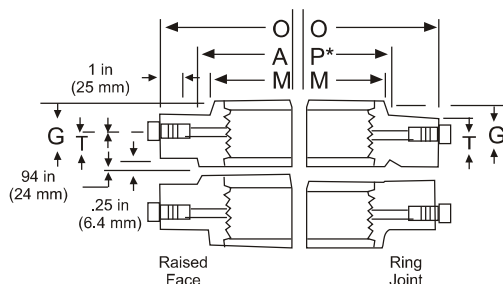

**CLASS 900 (PN 150)**  
**CLASS 1500 (PN 250)**  
**FORGED**  
**ORIFICE FLANGES**  
**ASTM A-105**  
**ASME/ANSI B16.36**

NPS	DN	DRILLING			BOLTING		DIAMETER OF HUB		APPROXIMATE WEIGHT				
		NO. OF HOLES	DIA. OF HOLES	DIA. OF BOLT CIRCLE	BOLT DIA. (Inches)	RAISED FACE	RING JOINT	AT BASE M	AT POINT OF WELDING N	WELDING NECK		SLIP-ON AND SCREWED	
										RAISED FACE	RING JOINT	RAISED FACE	RING JOINT
3		8	1.00	7.50	7/8	6.0	6.5	5.00	3.50	75	84	65	74
	80	8	26	191	7/8	153	165	127	89.0	34	38	30	33
4		8	1.25	9.25	1 1/8	7.00	7.5	6.25	4.50	125	140	130	145
	100	8	32	235	1 1/8	178	191	159	114.0	57	64	59	65
5		8	1.38	11.00	1 1/4	7.50	8.00	7.50	5.56	205	225	200	215
	125	8	36	279	1 1/4	191	204	191	141.3	93	102	91	97
6		12	1.25	12.50	1 1/8	7.75	8.25	9.25	6.63	260	290	260	285
	150	12	32	318	1 1/8	197	210	235	168.0	118	132	118	128
8		12	1.50	15.50	1 3/8	9.00	9.5	11.75	8.63	420	450	410	435
	200	12	39	394	1 3/8	229	241	298	219.0	191	204	186	196
10		16	1.50	18.50	1 3/8	9.5	10.0	14.50	10.75	610	660	580	620
	250	16	39	470	1 3/8	241	254	368	273.0	277	299	263	279
12		20	1.50	21.00	1 3/8	10.25	10.75	16.50	12.75	760	820	760	820
	300	20	39	533	1 3/8	260	273	419	324.0	345	372	345	360

NPS	DN	DRILLING			BOLTING		DIAMETER OF HUB		APPROXIMATE WEIGHT				
		NO. OF HOLES	DIA. OF HOLES	DIA. OF BOLT CIRCLE	BOLT DIA. (Inches)	LENGTH		AT BASE M	AT POINT OF WELDING N	WELDING NECK		SLIP-ON AND SCREWED	
						RAISED FACE	RING JOINT			RAISED FACE	RING JOINT	RAISED FACE	RING JOINT
1		4	1.00	4.00	7/8	6.00	6.25	2.06	1.32	29	28	26	26
	25	4	26	102	7/8	153	159	52	33.5	13	13	12	12
1 1/4		4	1.00	4.38	7/8	5.50	5.75	2.50	1.66	31	31	29	29
	32	4	26	111	7/8	140	147	64	42.2	14	14	13	13
1 1/2		4	1.12	4.88	1	6.25	6.50	2.75	1.90	38	40	36	38
	40	4	29	124	1	159	166	70	48.5	17	18	16	17
2		8	1.00	6.50	7/8	6.00	6.50	4.12	2.38	63	72	63	71
	50	8	26	165	7/8	153	166	105	60.5	29	33	29	32
2 1/2		8	1.12	7.50	1	6.50	7.00	4.88	2.88	90	100	90	100
	65	8	29	191	1	165	178	124	73.0	41	45	41	45
3		8	1.25	8.00	1 1/8	7.25	7.75	5.25	3.50	120	135	120	135
	80	8	32	203	1 1/8	185	197	133	89.0	54	61	54	61
4		8	1.38	9.50	1 1/4	8.00	8.50	6.38	4.50	180	195	180	195
	100	8	35	241	1 1/4	204	216	162	114.0	82	88	82	88
5		8	1.62	11.50	1 1/2	9.75	10.25	7.75	5.56	320	345	320	340
	125	8	42	292	1 1/2	248	261	197	141.0	145	157	145	153
6		12	1.50	12.50	1 3/8	10.50	11.00	9.00	6.63	405	440	405	435
	150	12	39	318	1 3/8	267	280	229	168.0	184	200	184	196
8		12	1.75	15.50	1 5/8	11.75	12.50	11.50	8.63	630	730	600	680
	200	12	45	394	1 5/8	299	318	292	219.0	286	331	272	305
10		12	2.00	19.00	1 7/8	13.50	14.25	14.50	10.75	1100	1175	1050	1125
	250	12	51	483	1 7/8	343	362	368	273.0	499	533	476	506
12		16	2.12	22.50	2	15.00	16.00	17.75	12.75	1675	1825	1475	1550
	300	16	54	572	2	381	407	451	324.0	760	828	664	698

INCHES	POUNDS
MILLIMETRES	KILOGRAMS

The tapped metering holes are drilled as follows: 1/2" for sizes NPS 4 (DN 100) and over.



**DIMENSIONS OF LARGE MALE-FEMALE AND SMALL TONGUE AND GROOVE FLANGE FACING ANSI B 16.5 STANDARD**

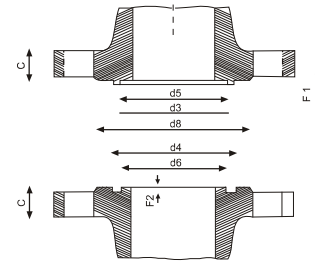
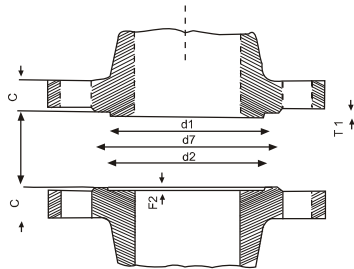

DN	d1	d2	d3	d4	d5	d6	d7	d8	f <sub>1</sub>	f <sub>2</sub>
1/2"	1,38 (35,1)	1,44 (36,6)	1,38 (35,1)	1,44 (36,6)	1,00 (25,4)	0,94 (23,9)	1,81 (46,0)	1,75 (44,5)	0,25 (6,4)	0,19 (4,8)
3/4"	1,69 (42,9)	1,75 (44,5)	1,69 (42,9)	1,75 (44,5)	1,31 (33,3)	1,25 (31,8)	2,12 (53,8)	2,06 (52,3)	0,25 (6,4)	0,19 (4,8)
1"	2,00 (50,8)	2,06 (52,3)	1,88 (47,7)	1,94 (49,3)	1,50 (38,1)	1,44 (36,6)	2,44 (62,0)	2,25 (57,2)	0,25 (6,4)	0,19 (4,8)
1 1/4"	2,50 (63,5)	2,56 (65,0)	2,25 (57,2)	2,31 (58,7)	1,88 (47,8)	1,81 (46,0)	2,94 (74,7)	2,62 (66,6)	0,25 (6,4)	0,19 (4,8)
1 1/2"	2,88 (73,2)	2,94 (74,7)	2,50 (63,5)	2,56 (65,0)	2,12 (53,8)	2,06 (52,3)	3,31 (84,1)	2,88 (73,2)	0,25 (6,4)	0,19 (4,8)
2"	3,62 (92,0)	3,69 (93,7)	3,25 (82,6)	3,31 (84,1)	2,88 (73,0)	2,81 (71,4)	4,06 (103,1)	3,62 (92,0)	0,25 (6,4)	0,19 (4,8)
2 1/2"	4,12 (104,6)	4,19 (106,4)	3,75 (95,2)	3,81 (96,8)	3,38 (85,8)	3,31 (84,1)	4,56 (115,8)	4,12 (104,6)	0,25 (6,4)	0,19 (4,8)
3"	5,00 (127,0)	5,06 (128,5)	4,62 (117,5)	4,69 (119,1)	4,25 (108,0)	4,19 (106,4)	5,44 (138,2)	5,00 (127,0)	0,25 (6,4)	0,19 (4,8)
4"	6,19 (157,2)	6,25 (158,8)	5,69 (144,5)	5,75 (146,1)	5,19 (131,8)	5,12 (130,0)	6,62 (168,1)	6,19 (157,2)	0,25 (6,4)	0,19 (4,8)
5"	7,31 (185,7)	7,38 (187,5)	6,81 (173,0)	6,88 (174,8)	6,31 (160,3)	6,25 (158,8)	7,75 (196,9)	7,31 (185,7)	0,25 (6,4)	0,19 (4,8)
6"	8,50 (215,9)	8,56 (217,5)	8,00 (203,2)	8,31 (211,1)	7,62 (194,0)	7,55 (192,5)	8,62 (219,0)	8,19 (207,6)	0,25 (6,4)	0,19 (4,8)
8"	10,62 (269,8)	10,69 (271,5)	10,00 (254,0)	10,06 (255,5)	9,38 (238,3)	9,31 (236,5)	11,06 (281,0)	10,62 (269,8)	0,25 (6,4)	0,19 (4,8)
10"	12,75 (323,5)	12,81 (325,4)	12,00 (304,8)	12,06 (306,3)	11,25 (285,8)	11,19 (284,2)	13,19 (335,0)	12,75 (323,5)	0,25 (6,4)	0,19 (4,8)
12"	15,00 (381,0)	15,06 (382,5)	14,25 (362,0)	14,31 (363,5)	13,50 (342,9)	13,44 (341,4)	15,44 (392,2)	15,00 (381,0)	0,25 (6,4)	0,19 (4,8)
14"	16,25 (412,8)	16,31 (414,3)	15,50 (393,7)	15,56 (395,2)	14,75 (374,7)	14,69 (373,1)	16,69 (423,9)	16,25 (412,8)	0,25 (6,4)	0,19 (4,8)
16"	18,50 (469,9)	18,56 (471,5)	17,62 (447,6)	17,69 (449,3)	16,75 (425,5)	16,69 (423,9)	18,94 (481,0)	18,50 (469,9)	0,25 (6,4)	0,19 (4,8)
18"	21,00 (533,4)	21,06 (535,0)	20,12 (511,0)	20,19 (512,8)	19,25 (489,0)	19,19 (487,4)	21,44 (544,6)	21,00 (533,4)	0,25 (6,4)	0,19 (4,8)
20"	23,00 (584,2)	23,06 (585,8)	22,00 (558,8)	22,06 (560,3)	21,00 (533,4)	20,94 (531,9)	23,44 (595,4)	23,00 (584,2)	0,25 (6,4)	0,19 (4,8)
24"	27,25 (692,2)	27,31 (693,7)	26,25 (666,9)	26,31 (668,3)	25,25 (641,4)	25,19 (639,8)	27,69 (703,3)	27,25 (692,2)	0,25 (6,4)	0,19 (4,8)



## FACING RING JOINING FLANGE ANSI B16.5

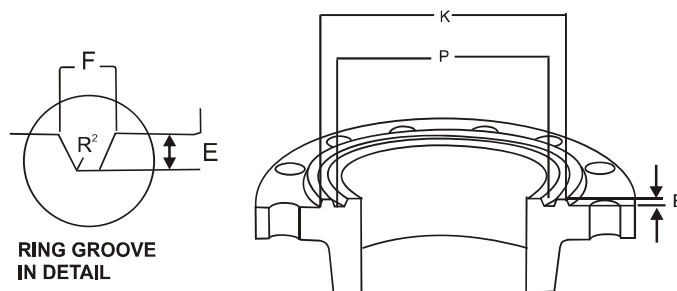

INCH

Nominal Pipe Size	CLASS 150						CLASS 300, 400, 600					
	Pitch Dia of Groove	Width of Groove	Depth of Groove	Radius of Groove Bottom	Diam of Raised Face	Ring Number	Pitch Dia of Groove	Width of Groove	Depth of Groove	Radius of Groove Bottom	Diam of Raised Face	Ring Number
	P	F	E	r2	K		P	F	E	r2	K	
1/2"	-	-	-	-	-	-	1.344	0.281	0.240	-	2.00	R11
3/4"	-	-	-	-	-	-	1.688	0.344	0.250	-	2.50	R13
1"	1.875	0.344	0.250	0.03	2.50	R15	2.000	0.344	0.250	0.03	2.75	R16
1 1/4"	2.250	0.344	0.250	0.03	2.80	R17	2.375	0.344	0.250	0.03	3.12	R18
1 1/2"	2.502	0.344	0.250	0.03	3.25	R19	2.680	0.344	0.250	0.03	3.56	R20
2"	3.250	0.344	0.250	0.03	4.00	R22	3.250	0.469	0.312	0.03	4.25	R23
2 1/2"	4.000	0.344	0.250	0.03	4.75	R25	4.000	0.469	0.312	0.03	5.00	R26
3"	4.500	0.344	0.250	0.03	5.25	R29	4.875	0.469	0.312	0.03	5.75	R31
3 1/2"	5.188	0.344	0.250	0.03	6.06	R33	5.188	0.469	0.312	0.03	6.25	R34
4"	5.875	0.344	0.250	0.03	6.75	R36	5.875	0.469	0.312	0.03	6.88	R37
5"	6.720	0.344	0.250	0.03	7.62	R40	7.125	0.469	0.312	0.03	8.25	R41
6"	7.625	0.344	0.250	0.03	8.62	R43	8.312	0.469	0.312	0.03	9.50	R45
8"	9.750	0.344	0.250	0.03	10.75	R48	10.625	0.469	0.312	0.03	11.88	R49
10"	12.000	0.344	0.250	0.03	13.00	R52	12.750	0.469	0.312	0.03	14.00	R53
12"	15.000	0.344	0.250	0.03	16.00	R56	15.500	0.469	0.312	0.03	16.25	R57
14"	15.625	0.344	0.250	0.03	16.75	R59	16.500	0.469	0.312	0.03	18.00	R61
16"	17.875	0.344	0.250	0.03	19.00	R64	18.500	0.469	0.312	0.03	20.00	R65
18"	20.375	0.344	0.250	0.03	21.50	R68	21.000	0.469	0.312	0.03	22.50	R69
20"	22.000	0.344	0.250	0.03	23.50	R72	23.000	0.531	0.375	0.03	25.00	R73
22"	24.262	0.344	0.250	0.03	25.50	R80	25.000	0.594	0.438	0.03	27.00	R81
24"	26.500	0.344	0.250	0.03	28.00	R76	27.250	0.656	0.438	0.03	28.50	R77

TOLERANCE : P ± 0.005", F ± 0.006", E ± 0.016"



## SPECTACLE BLINDS

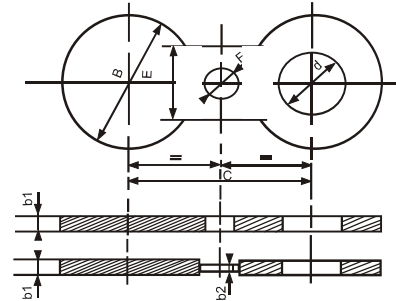

DN	150lbs							300lbs						
	B	d	C	E	b1	b2	F	B	d	C	E	b1	b2	F
1/2	44	16	60	25	6.5	4	16	51	16	67	30	6.5	4	16
3/4	54	22	70	30	6.5	4	16	63	22	83	35	6.5	4	16
1	63	28.5	79	35	6.5	4	16	70	28.5	89	40	6.5	4	16
1 1/4	73	35	89	40	6.5	4	16	79	35	98	45	6.5	4	16
1 1/2	82	41.5	98	50	6.5	4	16	92	41.5	114	55	6.5	4	23
2	101	54	121	50	6.5	4	19	108	54	127	28	6.5	4	16
2 1/2	120	66.5	140	50	6.5	4	19	127	66.5	149	35	6.5	4	23
3	133	79.5	152	60	6.5	4	19	146	79.5	168	40	9.5	6	23
3 1/2	159	92	178	45	6.5	4	19	162	92	184	45	9.5	6	23
4	171	108	191	50	6.5	4	19	178	108	200	50	12.5	8	23
5	193	133.5	216	55	9.5	6	22	212	133.5	235	60	12.5	8	23
6	219	159	241	60	9.5	6	22	247	159	270	45	16	8	23
8	276	209.5	298	70	12.5	8	22	305	209.5	330	55	19	10	23
10	336	260.5	362	65	16	8	26	359	260.5	387	45	25.5	14	23
12	406	305	432	70	22.5	10	26	419	305	451	50	28.5	18	23
14	441	336.5	476	70	25.5	14	29	476	336.5	514	45	32	20	23
16	505	387.5	540	70	25.5	14	29	530	387.5	572	50	36.5	22	23
18	540	438	578	70	25.5	14	32	587	438	629	45	41.5	24	23
20	597	489	635	65	28.5	18	32	645	489	686	50	44.5	24	23
22	657	546	692	65	35	20	35	702	546	743	50	44.5	24	23
24	708	590.5	750	75	35	20	35	765	590.5	813	60	54	40	23
26	762	641.5	806	70	51	32	35	822	641.5	876	50	73	60	23
28	828	692	864	60	51	32	35	895	692	940	60	73	60	23
30	870	743	914	65	54	34	35	940	743	997	60	85	70	23
32	936	794	978	65	54	34	41	1003	794	1054	65	85	70	23
34	978	844.5	1029	55	57	34	41	1044	844.5	1105	70	98	80	23
36	1035	895.5	1086	60	57	34	41	1105	895.5	1168	55	98	80	23

DN	400lbs							600lbs						
	B	d	C	E	b1	b2	F	B	d	C	E	b1	b2	F
1/2	51	16	67	30	6.5	4	16	51	16	67	30	6.5	4	16
3/4	63	22	83	35	6.5	4	16	63	22	83	35	6.5	4	16
1	70	28.5	89	40	9.5	6	19	70	28.5	89	40	9.5	6	19
1 1/4	79	35	98	45	9.5	6	19	79	35	98	50	9.5	6	19
1 1/2	92	41.5	114	55	9.5	6	23	92	41.5	114	55	9.5	6	23
2	108	54	127	28	9.5	6	16	108	54	127	28	9.5	6	16
2 1/2	127	63.5	149	35	9.5	6	23	127	63.5	149	35	12.5	8	23
3	146	79.5	168	40	12.5	8	23	146	79.5	168	40	16	10	23
3 1/2	159	92	184	45	12.5	8	23	159	92	184	45	16	10	23
4	174	105	200	50	16	10	23	190	105	216	55	16	10	23
5	209	130	235	60	16	10	23	238	130	267	70	22.5	14	23
6	244	155.5	270	45	19	12	23	263	155.5	292	45	25.5	16	23
8	301	203	330	55	22.5	14	23	317	203	349	55	32	20	23
10	355	257	387	45	28.5	16	23	390	257	432	45	38	24	23
12	416	305	451	50	38	24	23	454	305	489	40	44.5	30	23
14	479	336.5	514	45	41.5	26	23	489	336.5	527	40	51	36	23
16	533	387.5	572	50	47.5	30	23	562	387.5	603	50	57	40	23
18	590	438	629	45	57	40	23	609	438	654	55	63	50	23
20	644	489	686	50	57	40	23	679	489	724	50	70	64	23
22	698	540	743	50	70	55	23	730	540	778	55	70	64	23
24	765	590.5	813	60	70	55	23	787	590.5	838	55	82	68	23
26	819	641.5	876	50	85	70	23	851	641.5	915	50	101	85	23
28	889	692.2	783	60	85	70	23	911	692.2	965	55	101	85	23
30	930	743	997	60	98	80	23	959	743	1022	60	110	90	23
32	1000	794	918	65	98	80	23	1119	794	1080	60	110	90	23
34	1041	844.5	1105	70	105	90	23	1060	844.5	1130	65	117	100	23
36	1105	895.5	1168	55	110	95	23	1117	895.5	1194	65	124	110	23

NOTE 1. Preferably one piece except for stainless and allied steels, which can be manufactured in 3 pieces.  
2. Dimension of other standards available on request.

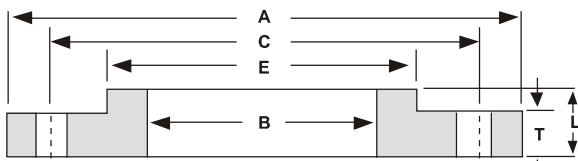

**SAME AS AWWA CLASS D HUB**

**Class 125LW\* (175-150psi)**

Nominal Pipe Size						Drilling Template			Weight
	OD of Flange	ID of Flange	Thickness of Flange	Overall Thickness	Diam. Of Hub	Number of Bolt Holes	Diam. of Bolt Holes	Diam. of Bolt Circle	
	(A)	(B)	(T)	(L)	(E)		(C)		
4	9.00	4.57	0.500	0.875	5.312	8	0.750	7.50	7
5	10.00	5.66	0.562	1.250	6.312	8	0.875	8.50	9
6	11.00	6.72	0.562	1.250	7.562	8	0.875	9.50	11
8	13.50	8.72	0.562	1.250	9.688	8	0.875	11.75	15
10	16.00	10.88	0.688	1.250	12.000	12	1.000	14.25	22
12	19.00	12.88	0.688	1.250	14.375	12	1.000	17.00	33
14	21.00	14.19	0.750	1.250	15.750	12	1.125	18.75	43
16	23.50	16.19	0.750	1.250	18.000	16	1.125	21.25	52
18	25.00	18.19	0.750	1.250	19.875	16	1.250	22.75	52
20	27.50	20.19	0.750	1.250	22.000	20	1.250	25.00	61
22	29.50	22.19	1.000	1.750	24.250	20	1.375	27.25	92
24	32.00	24.19	1.000	1.750	26.125	20	1.375	29.50	105
26	34.25	26.19	1.000	1.750	28.500	24	1.375	31.75	119
28	36.50	28.19	1.000	1.750	30.500	28	1.375	34.00	130
30	38.75	30.19	1.000	1.750	32.500	28	1.375	36.00	144
32	41.75	32.19	1.125	1.750	34.750	28	1.625	38.50	182
34	43.75	34.19	1.125	1.750	36.750	32	1.625	40.50	191
36	46.00	36.19	1.125	1.750	38.750	32	1.625	42.75	207
38	48.75	38.19	1.125	1.750	40.750	32	1.625	45.25	237
40	50.75	40.19	1.125	1.750	43.000	36	1.625	47.25	249
42	53.00	42.19	1.250	1.750	45.000	36	1.625	49.50	287
44	55.25	44.19	1.250	2.250	47.000	40	1.625	51.75	334
46	57.25	46.19	1.250	2.250	49.000	40	1.625	53.75	348
48	59.50	48.19	1.375	2.500	51.000	44	1.625	56.00	407
50	61.75	50.19	1.375	2.500	53.000	44	1.875	58.25	421
52	64.00	52.19	1.375	2.500	55.000	44	1.875	60.50	448
54	66.25	54.19	1.375	2.500	57.000	44	1.875	62.75	475
60	73.00	60.19	1.500	2.750	63.000	52	1.875	69.25	605
66	80.00	66.19	1.500	2.750	69.000	52	1.875	76.00	718
72	86.50	72.19	1.500	2.750	75.000	60	1.875	82.50	803
78	93.00	78.19	1.750	3.000	81.250	64	2.125	89.00	1010
84	99.75	84.19	1.750	3.000	87.500	64	2.125	95.50	1160
90	106.50	90.19	2.000	3.250	93.750	68	2.438	102.00	1430
96	113.25	96.19	2.000	3.250	100.000	68	2.438	108.50	1618

**Note :** All dimensions measured in inches. All weights in pounds and are approximate. Hub Flanges are to be used on pipe that has an OD equal to the nominal pipe size in the first column. \* Pressure Ratings are from AWWA Table 3 Class D. Pressure rating at atmospheric temperature: sizes 4-12in. Inclusive, 175 psi; sizes larger than 12 in., 150 psi. These flanges have the same diameter and drilling as ANSI/ASME B16.1 class 125 cast-iron flanges. In Sizes 24 in. and smaller they also match up to ANSI/ASME B 16.5 150 - psi standard for steel flanges.

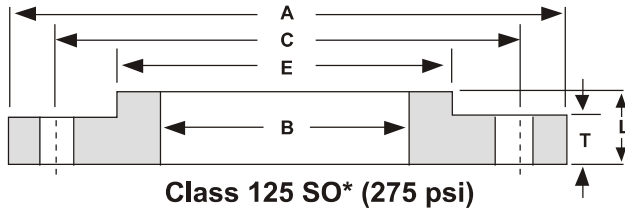

**SAME AS AWWA TABLE 4 CLASS E**

**Class 125 SO\* (275 psi)**

Nom Pipe Size						Drilling Template			Weight
	OD of Flange	ID of Flange	Thickness of Flange	Overall Thickness	Diam. of Hub	Number of bolt Holes	Diam. of Bolt Hub	Diam. of Bolt Circle	
	(A)	(B)	(T)	(L)	(E)		(C)		
4	9.00	4.57	0.938	1.312	5.312	8	0.750	7.50	13
5	10.00	5.66	0.938	1.438	6.438	8	0.875	8.50	14
6	11.00	6.72	1.000	1.562	7.562	8	0.875	9.50	17
8	13.50	8.72	1.125	1.750	9.688	8	0.875	11.75	28
10	16.00	10.88	1.188	1.938	12.000	12	1.000	14.25	37
12	19.00	12.88	1.250	2.188	14.375	12	1.000	17.00	59
14	21.00	14.19	1.375	2.250	15.750	12	1.125	18.75	78
16	23.50	16.19	1.438	2.500	18.000	16	1.125	21.25	101
18	25.00	18.19	1.562	2.688	19.875	16	1.250	22.75	110
20	27.50	20.19	1.688	2.875	22.000	20	1.250	25.00	139
22	29.50	22.19	1.812	3.125	24.000	20	1.375	27.25	162
24	32.00	24.19	1.875	3.250	26.125	20	1.375	29.50	197
26	34.25	26.19	2.000	3.375	28.500	24	1.375	31.75	235
28	36.50	28.19	2.062	3.438	30.750	28	1.375	34.00	269
30	38.75	30.19	2.125	3.500	32.750	28	1.375	36.00	303
32	41.75	32.19	2.250	3.625	35.000	28	1.625	38.50	375
34	43.75	34.19	2.312	3.688	37.000	32	1.625	40.50	401
36	46.00	36.19	2.375	3.750	39.250	32	1.625	42.75	452
38	48.75	38.19	2.375	3.750	41.750	32	1.625	45.25	528
40	50.75	40.19	2.500	3.875	43.750	36	1.625	47.25	573
42	53.00	42.19	2.625	4.000	46.000	36	1.625	49.50	648
44	55.25	44.19	2.625	4.000	48.000	40	1.625	51.75	688
46	57.25	46.19	2.688	4.062	50.000	40	1.625	53.75	733
48	59.50	48.19	2.750	4.125	52.250	44	1.625	56.00	799
50	61.75	50.19	2.750	4.125	54.250	44	1.875	58.25	827
52	64.00	52.19	2.875	4.250	56.500	44	1.875	60.50	922
54	66.25	54.19	3.000	4.375	58.750	44	1.875	62.75	1024
60	73.00	60.19	3.125	4.500	65.250	52	1.875	69.25	1253
66	80.00	66.19	3.375	4.875	71.500	52	1.875	76.00	1623
72	86.50	72.19	3.500	5.000	78.500	60	1.875	82.50	1922
78	93.00	78.19	3.875	5.375	84.500	64	2.125	89.00	2279
84	99.75	84.19	3.875	5.375	90.500	64	2.125	95.50	2586
90	106.50	90.19	4.250	5.750	96.750	68	2.438	102.00	3061
96	113.25	96.19	4.250	5.750	102.750	68	2.438	108.50	3432

Notes : Commonly referred to as a class 150# in large diameter. Can be furnished with a raised face. All dimensions measured in inches. All weights in pounds and are approximate. \* Pressure ratings from AWWA table 4 Class E. Pressure rating at atmospheric is 275 psi. These flanges have the same diameter and drilling as ANSI/ASME B16.1 class 125 cast-iron flanges. In Sizes 24in and smaller they also match ANSI/ASME b16.5 150-psi standard for steel flange. The thickness of a 150-psi flange from which the raised face has been removed shall be no less than dimension T minus 0.06 in.



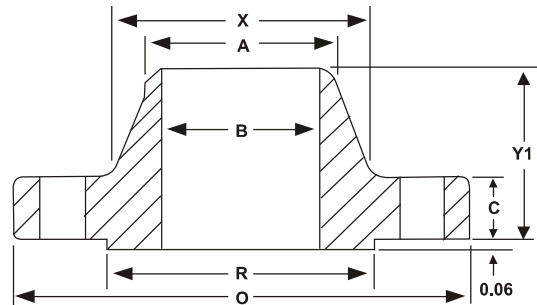

### Class 125WN

Nom Pipe Size								Drilling Template			
	OD of Flange	ID of Flange	Thick	Overall Thickness	Diam. of Hub	OD of Raised Face	Diam. Hub At Bev.	# of Bolt Holes	Diam. Of Bolt Holes	Diam. Of Bolt Circle	Weight
	(O)	(B)	(C)	(Y)	(X)	(R)	(A)				
6	11.00		1.000	3.50	7.562	8.50	6.63	8	0.875	9.50	24
8	13.50		1.125	4.00	9.688	10.63	8.63	8	0.875	11.75	39
10	16.00		1.188	4.00	12.000	12.75	10.75	12	1.000	14.25	52
12	19.00		1.250	4.50	14.375	15.00	12.75	12	1.000	17.00	80
14	21.00		1.375	5.00	15.750	16.25	14.00	12	1.125	18.75	110
16	23.50		1.438	5.00	18.000	18.50	16.00	16	1.125	21.25	140
18	25.00		1.562	5.50	19.875	21.00	18.00	16	1.250	22.75	150
20	27.50		1.688	5.69	22.000	23.00	20.00	20	1.250	25.00	180
22	29.50		1.812	5.88	24.000	25.25	22.00	20	1.375	27.25	225
24	32.00		1.875	6.00	26.125	27.25	24.00	20	1.375	29.50	255
26	34.25		2.000	5.00	28.500	29.50	26.00	24	1.375	31.75	265
28	36.50		2.062	5.06	30.750	31.50	28.00	28	1.375	34.00	295
30	38.75		2.125	5.13	32.750	33.75	30.00	28	1.375	36.00	340
32	41.75		2.250	5.25	35.000	36.00	32.00	28	1.625	38.50	410
34	43.75		2.312	5.31	37.000	38.00	34.00	32	1.625	40.50	440
36	46.00		2.375	5.38	39.250	40.25	36.00	32	1.625	42.75	495
38	48.75		2.375	5.38	41.750	42.25	38.00	32	1.625	45.25	570
40	50.75		2.500	5.50	43.750	44.25	40.00	36	1.625	47.25	620
42	53.00		2.625	5.63	46.000	47.00	42.00	36	1.625	49.50	710
44	55.25		2.625	5.63	48.000	49.00	44.00	40	1.625	51.75	750
46	57.25		2.688	5.68	50.000	51.00	46.00	40	1.625	53.75	800
48	59.50		2.750	5.75	52.750	53.50	48.00	44	1.625	56.00	870
50	61.75		2.750	5.75	54.250	55.50	50.00	44	1.875	58.25	900
52	64.00		2.875	5.88	56.500	57.50	52.00	44	1.875	60.50	1000
54	66.25		3.000	6.00	58.750	59.75	54.00	44	1.875	62.75	1100
60	73.00		3.125	6.13	65.250	66.00	60.00	52	1.875	69.25	1350
66	80.00		3.375	6.38	71.500	-	66.00	52	1.875	76.00	1775
72	86.50		3.500	6.50	78.500	-	72.00	60	1.875	82.50	2100
84	99.75		3.875	6.88	90.500	-	84.00	64	2.125	95.50	3800
96	113.25		4.250	7.25	102.750	-	96.00	68	2.438	108.50	

To Be Specified Purchaser

**Notes :** Can be furnished with a flat face. All Dimensions measured in inches. All weights in pounds and are approximate. These flanges have the same diameter and drilling as ANSI/ASME B16.1 Class 125 cast-iron flanges.



## Class 250\* (300psi)

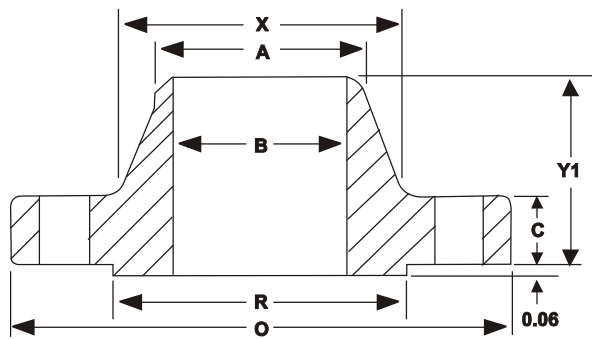

Weld Neck (B determined by Purchaser)

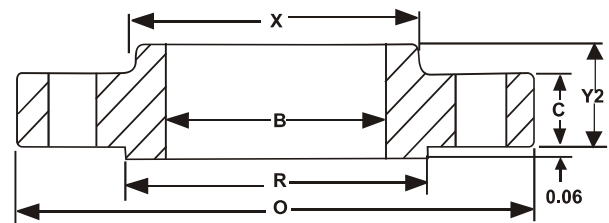

Slip On

### Matches B16.1 Class 250 Valves and Pumps

Nominal Pipe Size	OD of Flange	ID of Flange	Thick	LTH			Drilling Template			Weights		
				WN	SO	Hub Dia	Number of Bolt Holes	Diam. of Bolt Holes	Diam. of Bolt Circle	Weld Neck	Slip-on	Blind
				(Y)	(Y)	(X)						
	(O)	(B)	(C)	(Y)	(Y)	(X)						
26	38.25	26.25	2.81	5.81	4.75	30.50	28	1.875	34.50	534	531	916
28	40.75	28.25	2.94	5.94	5.00	33.00	28	1.875	37.00	629	637	1095
30	43.00	30.25	3.00	6.00	5.00	35.25	28	1.875	39.25	702	707	1236
32	45.25	32.25	3.12	6.12	5.12	37.50	28	1.875	41.50	793	801	1424
34	47.50	34.25	3.25	6.25	5.25	39.50	28	1.875	43.50	882	889	1649
36	50.00	36.25	3.38	6.38	5.38	41.50	32	2.125	46.00	969	970	1884
38	52.25	38.25	3.44	6.44	5.50	43.50	32	2.125	48.00	1057	1062	2094
40	54.25	40.25	3.56	6.56	5.50	45.75	36	2.125	50.25	1158	1172	2336
42	57.00	42.25	3.69	6.94	5.62	47.75	36	2.125	52.75	1318	1288	2673
44	59.25	44.25	3.75	7.00	5.75	49.75	36	2.125	55.00	1423	1397	2935
46	61.50	46.25	3.88	7.12	5.88	51.75	40	2.125	57.25	1536	1510	3272
48	65.00	48.25	4.00	7.25	6.00	54.00	40	2.125	60.75	1824	1797	3768

Notes: All dimensions measured in inches. All weights in pounds and are approximate.

\*AWWA Pressure rating at atmospheric temperature is 300 psi. These flanges have the same diameter and drilling as ANSI/ASME B16.1 class 250 cast iron pipe and flanged fittings.



## INDUSTRY STANDARD CLASS 75 SORF & BLIND

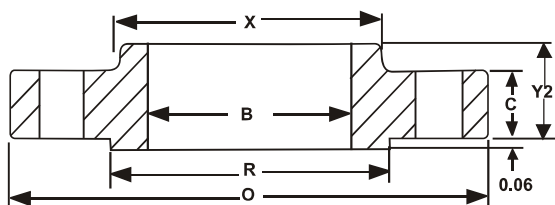

Slip On

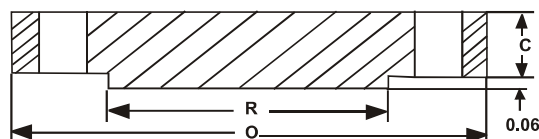

Blind

Nom Size	THICKNESS							Drilling			Weight	
	OD	Slip On	Blind	OD RF	Dia at Base	Bore	LTH	Bolt Circle	Dia Holes	# Holes	Slip On	Blind
	O	C	C	R	X	B	Y					
26	33.00	1.25	1.25	30.00	28.50	26.25	2.25	31.00	1.00	32	120	290
28	35.00	1.25	1.38	32.00	30.50	28.25	2.25	33.00	1.00	36	140	360
30	37.00	1.25	1.38	34.00	32.50	30.25	2.25	35.00	1.00	36	150	405
32	39.50	1.25	1.50	36.25	34.63	32.25	2.50	37.38	1.13	40	170	500
34	41.50	1.25	1.63	38.25	36.63	34.25	2.50	39.38	1.13	40	180	600
36	43.50	1.25	1.63	40.25	38.63	36.25	2.50	41.38	1.13	44	190	660
42	50.00	1.25	1.88	46.50	44.75	42.25	2.75	47.75	1.25	48	235	1000
48	56.00	1.25	2.13	52.50	50.75	48.25	2.88	53.75	1.25	56	270	1450
54	62.50	1.38	2.38	59.00	57.25	54.25	3.13	60.25	1.25	68	335	2000
60	68.50	1.63	2.63	65.00	63.25	60.25	3.63	66.25	1.25	72	450	2675
66	75.50	1.75	2.88	71.63	69.50	66.25	4.00	73.00	1.38	72	590	3550
72	81.50	2.00	3.13	77.63	75.50	72.25	4.50	79.00	1.38	80	730	4500

Dimensions in inches.

Note: Larger sizes as well as intermediate sizes can be furnished.



## INDUSTRY STANDARD CLASS 75 WELD NECK & BLIND

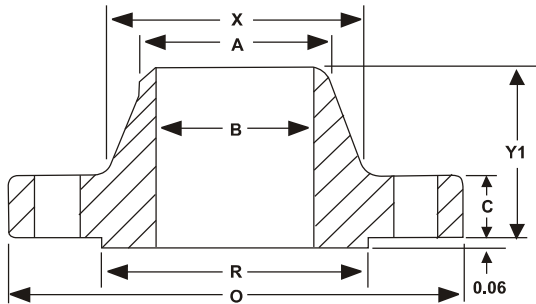

Weld Neck

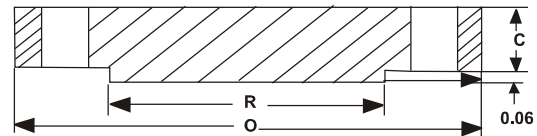

Blind

Nom Size	THICKNESS								Drilling			Weight	
	OD	Weld Neck	Blind	OD RF	Dia at Base	Bore	LTH	Dia Bevel	Bolt Circle	Dia Holes	# Holes	Weld Neck	Blind
	O	C	C	R	X	B	Y	A					
26	31.50	1.15	1.25	28.63	27.13	To be specified by purchaser.	3.00	To be determined by design requirements.	29.63	1.00	32	98	265
28	33.50	1.25	1.25	30.63	29.13		3.00		31.63	1.00	36	105	300
30	35.50	1.25	1.38	32.63	31.13		3.00		33.63	1.00	36	110	370
32	38.25	1.25	1.50	35.00	33.38		3.25		36.16	1.13	36	140	470
34	40.25	1.25	1.50	37.00	35.38		3.25		38.13	1.13	40	150	520
36	42.25	1.25	1.63	39.00	37.38		3.25		40.13	1.13	40	160	620
42	49.00	1.25	1.88	45.50	43.75		3.50		46.75	1.25	48	210	970
48	55.00	1.25	2.13	51.50	49.75		3.75		52.75	1.25	52	240	1375
54	61.25	1.38	2.38	57.75	56.00		4.00		59.00	1.25	64	310	1925
60	67.25	1.63	2.63	63.75	62.00		4.38		65.00	1.25	72	400	2575
66	74.00	1.88	2.88	70.13	68.00		4.88		71.50	1.38	72	560	3400
72	80.00	2.25	3.13	76.13	74.00		5.25		77.50	1.38	80	700	4350

Dimensions in inches.

Note: Larger sizes as well as intermediate sizes can be furnished.

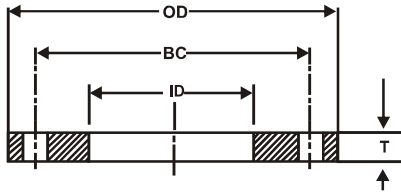

## AWWA C207-07, CLASS B, SLIP ON & BLIND

Dimensions in Inches

Nominal Size	Outside $\varnothing$ (OD)	Slip-on Bore (ID)	No. of Bolt Holes	$\varnothing$ of Holes	$\varnothing$ Bolt Circle (BC)	Thickness (T)		Weight (lbs)	
						Slip-on	Blind	Slip-on	Blind
4	9.00	4.57	8	0.750	7.50	0.938	1.312	5.312	13
5	10.00	5.66	8	0.875	8.50	0.938	1.438	6.438	-
6	11.00	6.72	8	0.875	9.50	1.000	1.562	7.562	19
8	13.50	8.72	8	0.875	11.75	1.125	1.750	9.688	30
10	16.00	10.88	12	1.000	14.25	1.188	1.938	12.000	43
12	19.00	12.88	12	1.000	17.00	1.250	2.188	14.375	64
14	21.00	14.19	12	1.125	18.75	1.375	2.250	15.750	85
16	23.50	16.19	16	1.125	21.25	1.438	2.500	18.000	93
18	25.00	18.19	16	1.250	22.75	1.562	2.688	19.875	120
20	27.50	20.19	20	1.250	25.00	1.688	2.875	22.000	155
22	29.50	22.19	20	1.375	27.25	1.812	3.125	24.250	-
24	32.00	24.19	20	1.375	29.50	1.875	3.250	26.125	210
26	34.25	26.19	24	1.375	31.75	2.000	3.375	28.500	-
28	36.50	28.19	28	1.375	34.00	2.062	3.438	30.750	-
30	38.75	30.19	28	1.375	36.00	2.125	3.500	32.750	305
32	41.75	32.19	28	1.625	38.50	2.250	3.625	35.000	-
36	46.00	36.19	32	1.625	42.75	2.375	3.750	39.250	450
38	48.75	38.19	32	1.625	45.25	2.375	3.750	41.750	-
40	50.75	40.19	36	1.625	47.25	2.500	3.875	43.750	-
42	53.00	42.19	36	1.625	49.50	2.625	4.000	46.000	605
44	55.25	44.19	40	1.625	51.75	2.625	4.000	48.000	-
48	59.50	48.19	44	1.625	56.00	2.750	4.125	52.250	800
54	66.25	54.19	44	1.875	62.75	3.000	4.375	58.750	1025
60	73.00	60.19	52	1.875	69.25	3.125	4.500	65.250	1250
66	80.00	66.19	52	1.875	76.00	3.375	4.875	71.500	-
72	86.50	72.19	60	1.875	82.50	3.500	5.000	78.500	1925
78	93.00	78.19	64	2.125	89.00	3.875	5.375	84.500	-
84	99.75	84.19	64	2.125	95.50	3.875	5.375	90.500	2600
90	106.50	90.19	68	2.438	102.00	4.250	5.750	96.750	-
96	113.25	96.19	68	2.438	108.50	4.250	5.750	102.750	3275

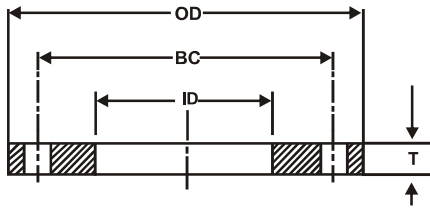

## AWWA C207-07, CLASS D, SLIP ON & BLIND

Dimensions in Inches

Nominal Size	Outside $\phi$ (OD)	Slip-on Bore (ID)	No. of Bolt Holes	$\phi$ of Holes	$\phi$ Bolt Circle (BC)	Thickness (T)		Weight (lbs)	
						Slip-on	Blind	Slip-on	Blind
2	6.00	2.44	4	0.750	4.75	0.625	0.625	3.90	4.7
2.5	7.00	2.94	4	0.750	5.50	0.625	0.625	5.30	6.5
3	7.50	3.57	4	0.750	6.00	0.625	0.625	5.70	7.5
4	9.00	4.57	8	0.750	7.50	0.625	0.625	7.70	10.6
5	10.00	5.66	8	0.875	8.50	0.625	0.650	8.80	13.6
6	11.00	6.72	8	0.875	9.50	0.688	0.693	10.70	17.7
8	13.50	8.72	8	0.875	11.75	0.688	0.812	15.30	31.8
10	16.00	10.88	12	1.000	14.25	0.688	0.953	19.20	51.7
12	19.00	12.88	12	1.000	17.00	0.812	1.117	33.10	86.7
14	21.00	14.19	12	1.125	18.75	0.938	1.133	46.90	107.4
16	23.50	16.19	16	1.125	21.25	1.000	1.265	60.10	149.8
18	25.00	18.19	16	1.250	22.75	1.062	1.331	63.60	177.7
20	27.50	20.19	20	1.250	25.00	1.125	1.448	79.40	233.6
22	29.50	22.19	20	1.375	27.25	1.188	1.568	89.90	290.5
24	32.00	24.19	20	1.375	29.50	1.250	1.661	113.40	364.5
26	34.25	26.25	24	1.375	31.75	1.312	1.786	128.00	448.2
28	36.50	28.25	28	1.375	34.00	1.312	1.906	140.50	542.6
30	38.75	30.25	28	1.375	36.00	1.375	2.008	163.30	647.3
32	41.75	32.25	28	1.625	38.50	1.500	2.150	210.10	798.6
34	43.75	34.25	32	1.625	40.50	1.500	2.252	219.10	916.9
36	46.00	36.25	32	1.625	42.75	1.625	2.370	259.40	1071.4
38	48.75	38.25	32	1.625	45.25	1.625	2.506	299.80	1278.2
40	50.75	40.25	36	1.625	47.25	1.625	2.609	311.10	1440.1
42	53.00	42.25	36	1.625	49.50	1.750	2.729	361.70	1648.1
44	55.25	44.25	40	1.625	51.75	1.750	2.849	385.00	1868.3
48	59.50	48.25	44	1.625	56.00	1.875	3.072	457.30	2340.7
54	66.25	54.25	44	1.875	62.75	2.125	3.435	610.60	3236.7
60	73.00	60.25	52	1.875	69.25	2.250	3.779	759.10	4327.6
66	80.00	66.25	52	1.875	76.00	2.500	4.136	1017.00	5722.2
72	86.50	72.25	60	1.875	82.50	2.625	4.480	1198.20	7249.0
78	93.00	78.25	64	2.125	89.00	2.750	-	1368.90	-
84	99.75	84.25	64	2.125	95.50	2.875	-	1639.70	-
90	106.50	90.25	68	2.438	102.00	3.000	-	1878.30	-
96	113.25	96.25	68	2.438	108.50	3.250	-	2298.30	-

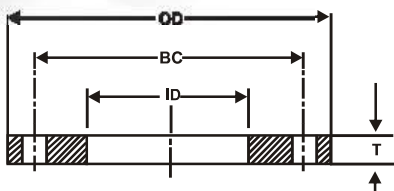

## AWWA C207-07, CLASS E, SLIP ON & BLIND

Dimensions in Inches

Nominal Size	Outside $\varnothing$ (OD)	Slip-on Bore (ID)	No. of Bolt Holes	$\varnothing$ of Holes	$\varnothing$ Bolt Circle (BC)	Thickness (T)		Weight (lbs)	
						Slip-on	Blind	Slip-on	Blind
4	9.00	4.57	8	0.750	7.50	1.125	1.125	13.90	19.2
5	10.00	5.66	8	0.875	8.50	1.188	1.188	16.30	24.8
6	11.00	6.72	8	0.875	9.50	1.313	1.313	20.40	33.6
8	13.50	8.72	8	0.875	11.75	1.500	1.500	33.40	60.8
10	16.00	10.88	12	1.000	14.25	1.563	1.563	43.70	84.9
12	19.00	12.88	12	1.000	17.00	1.750	1.750	71.30	135.9
14	21.00	14.19	12	1.125	18.75	1.875	1.875	93.70	177.7
16	23.50	16.19	16	1.125	21.25	2.000	2.000	120.10	236.8
18	25.00	18.19	16	1.250	22.75	2.125	2.125	127.30	283.7
20	27.50	20.19	20	1.250	25.00	2.375	2.375	167.70	383.2
24	32.00	24.19	20	1.375	29.50	2.625	2.625	234.30	576.1
26	34.25		24	1.375	31.75	2.750	2.750		690.1
28	36.50		28	1.375	34.00	2.750	2.750		782.9
30	38.75		28	1.375	36.00	2.875	2.875		926.8
36	46.00		32	1.625	42.75	3.125	3.209		1450.7
38	48.75		32	1.625	45.25	3.125	3.394		1731.1
40	50.75		36	1.625	47.25	3.250	3.533		1950.2
42	53.00		36	1.625	49.50	3.375	3.695		2231.5
44	55.25		40	1.625	51.75	3.375	3.857		2529.4
48	59.50		44	1.625	56.00	3.500	4.159		3169.0
54	66.25		44	1.875	62.75	3.750	4.651		4382.5
60	73.00		52	1.875	69.25	3.875	5.116		5858.7
66	80.00		52	1.875	76.00	4.250	5.601		7749.0
72	86.50		60	1.875	82.50	4.375	6.066		9815.3
78	93.00		64	2.125	89.00	4.750			
84	99.75		64	2.125	95.50	4.750			
90	106.50		68	2.438	102.00	5.125			
96	113.25		68	2.438	108.50	5.125			

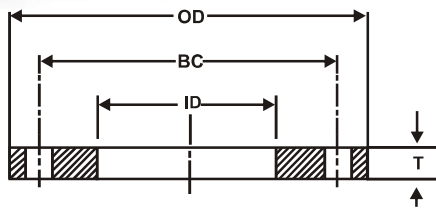

## AWWA C207-07, CLASS F, SLIP ON & BLIND

Dimensions in Inches

Nominal Size	Outside $\phi$ (OD)	Slip-on Bore (ID)	No. of Bolt Holes	$\phi$ of Holes	$\phi$ Bolt Circle (BC)	Thickness (T)		Weight (lbs)	
						Slip-on	Blind	Slip-on	Blind
4	10.00	4.57	8	0.875	7.88	1.130	1.130	18.30	23.6
5	11.00	5.66	8	0.875	9.25	1.210	1.210	22.30	30.9
6	12.50	6.73	12	0.875	10.63	1.310	1.310	29.70	42.9
8	15.00	8.73	12	1.000	13.00	1.310	1.310	39.90	62.1
10	17.50	10.88	16	1.125	15.25	1.500	1.500	56.00	95.5
12	20.50	12.88	16	1.250	17.75	1.630	1.630	83.20	143.4
14	23.00	14.19	20	1.250	20.25	1.940	1.940	127.90	214.9
16	25.50	16.19	20	1.375	22.50	2.140	2.140	166.80	291.7
18	28.00	18.19	24	1.375	24.75	2.250	2.250	204.20	369.8
20	30.50	20.19	24	1.375	27.00	2.330	2.330	247.40	458.8
22	33.00	22.19	24	1.375	29.25	2.500	2.500	306.70	580.6
24	36.00	24.19	24	1.625	32.00	2.690	2.690	387.60	737.9
26	38.25		28	1.875	34.50	3.000	3.000		911.0
28	40.75		28	1.875	37.00	3.130	3.130		1088.0
30	43.00		28	1.875	39.25	3.150	3.166		1233.3
32	45.25		28	1.875	41.50	3.250	3.332		1445.2
34	47.50		28	1.875	43.50	3.380	3.475		1668.6
36	50.00		32	2.125	46.00	3.460	3.671		1924.2
38	52.25		32	2.125	48.00	3.500	3.815		2195.0
40	54.25		36	2.125	50.25	3.630	3.982		2463.8
42	57.00		36	2.125	52.75	3.810	4.171		2864.7
44	59.25		36	2.125	55.00	4.000	4.338		3231.9
46	61.50		40	2.125	57.25	4.130	4.505		3610.6
48	65.00		40	2.125	60.75	4.500	4.781		4302.9





# 6BAR

DIN 2573 SLIP - ON FLANGES

DIN 2527 BLIND FLANGES

DIN 2631 WELDING NECK FLANGES

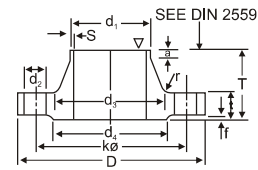

WELDING NECK

Unit : mm

Bore		Common Dimension						Hub				Raise Face		Drilling			Approx Weight (kg)			
Nominal Bore	d <sub>1</sub>	D	t	K	T	d <sub>3</sub>	s	r	a	d <sub>4</sub>	f	No. of Bolt	Dia. of Bolt	d <sub>5</sub>	DIN 2573	DIN 2631				
			Welding neck	slip-on	Blind															
10	14 17.2*)	75	12	12	12	50	28	22	26	1.8	4	6	35	2	4	M10	-	11.5	0.036	0.335
15	20 21.3*)	80	12	12	12	55	30	28	30	2.0	4	6	40	2	4	M10	-	11.5	0.410	0.392
20	25 26.9*)	90	14	14	14	65	32	35	38	2.3	4	6	50	2	4	M10	-	11.5	0.600	0.592
25	30 33.7*)	100	14	14	14	75	35	40	42	2.6	4	6	60	2	4	M10	-	11.5	0.740	0.747
32	38 42.4*)	120	14	16	14	90	35	50	55	2.6	6	6	70	2	4	M12	(1/2")	14	1.19	1.05
40	44.5 48.3*)	130	14	16	14	100	38	58	62	2.6	6	7	80	3	4	M12	(1/2")	14	1.39	1.18
50	57 60.3*)	140	14	16	14	110	38	70	74	2.9	6	8	90	3	4	M12	(1/2")	14	1.53	1.34
65	76.1*)	160	14	16	14	130	38	88	98	2.9	6	9	110	3	4	M12	(1/2")	14	1.89	1.67
80	88.9*)	190	16	18	16	150	42	102	112	3.2	8	10	128	3	4	M16	(5/8")	18	2.98	2.71
100	108 114.3*)	210	16	18	16	170	45	122	130	3.6	8	10	148	3	4	M16	(5/8")	18	3.46	3.24
125	133 139.7*)	240	18	20	18	200	48	148	155	4.0	8	10	178	3	8	M16	(5/8")	18	4.60	4.49
150	159 168.3*)	265	18	20	18	225	48	172	184	4.5	10	12	202	3	8	M16	(5/8")	18	5.22	5.15
200	216 219.1*)	320	20	22	20	280	55	230	236	5.9	10	15	258	3	8	M16	(5/8")	18	7.15	7.78
250	267 273*)	375	22	24	22	335	60	282	290	6.2	12	15	312	3	12	M16	(5/8")	18	9.61	10.8
300	381 323.9*)	440	22	24	22	395	62	335	342	7.1	12	15	365	4	12	M20	(3/4")	23	12.6	14.0
350	355.6*)	490	22	26	22	445	62	385	395	7.1	12	15	415	4	12	M20	(3/4")	23	15.6	16.1
400	406.4*)	540	22	28	22	495	65	438	448	7.1	12	15	455	4	16	M20	(3/4")	23	18.4	18.3
500	508*)	645	24	30	24	600	68	538	548	7.1	12	15	570	4	20	M20	(3/4")	23	24.5	24.6
600	609.6*)	755	24			705	70	640	650	7.1	12	16	670	5	20	M24	(7/8")	27		
700	711.2*)	860	24			810	70	740	750	7.1	12	16	775	5	24	M24	(7/8")	27		
800	812.8*)	975	24			920	70	842	852	7.1	12	16	880	5	24	M27	(1")	30		
900	914.4*)	1075	26			1020	70	942	952	7.1	12	16	980	5	24	M27	(1")	30		
1000	1016*)	1175	26			1120	70	1045	1055	7.1	16	16	1080	5	28	M27	(1")	30		

Out side diameter of pipe complies with ISO recommendation R64



# 10BAR

DIN 2576 SLIP - ON FLANGES

DIN 2527 BLIND FLANGES

DIN 2632 WELDING NECK FLANGES

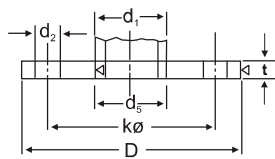

SLIP-ON

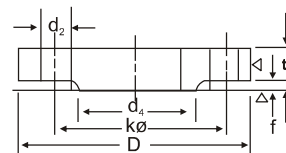

BLIND

Unit : mm

Bore		Common Dimension						Hub				Raise Face		Drilling			Approx Weight (kg)	
Nominal Bore	d <sub>1</sub>	D	t			K	T	d <sub>3</sub>	s	r	a ≈	d <sub>4</sub>	f	No. of Bolt	Dia. of Bolt	d <sub>2</sub>	DIN 2576	DIN 2632
			Welding neck	slip-on	Blind													
10	14 (17.2*)	90	14	14	14	60	35	25 28	1.8	4	6	40	2	4	M12 (1.2")	14	0.163	0.580
15	20 (21.3*)	95	14	14	14	65	35	30 32	2.0	4	6	45	2	4	M12 (1.2")	14	0.675	0.648
20	25 (26.9*)	105	16	16	16	75	38	38 40	2.3	4	6	58	2	4	M12 (1.2")	14	0.947	0.952
25	30 (33.7*)	115	16	16	16	85	38	42 45	2.6	4	6	68	2	4	M12 (1.2")	14	1.14	1.14
32	38 (42.4*)	140	16	16	16	100	40	52 56	2.6	6	6	78	2	4	M16 (5/8")	18	1.66	1.69
40	44.5 (48.3*)	150	16	16	18	110	42	60 64	2.6	6	7	88	3	4	M16 (5/8")	18	1.89	1.86
50	57 (60.3*)	165	18	18	18	125	45	72 75	2.9	6	8	102	3	4	M16 (5/8")	18	2.51	2.53
65	76.1*)	185	18	18	18	145	45	90	2.9	6	10	122	3	4	M16 (5/8")	18	3.00	3.06
80	88.9*)	200	20	20	20	160	50	105	3.2	8	10	138	3	4	M16 (5/8")	18	3.79	3.70
100	108 (114.3*)	220	20	20	20	180	52	125 131	3.6	8	12	158	3	8	M16 (5/8")	18	4.20	4.62
125	133 (139.7*)	250	22	22	22	210	55	150 156	4.0	8	12	188	3	8	M16 (5/8")	18	5.71	6.30
150	159 (168.3*)	285	22	22	22	240	55	175 184	4.5	10	12	212	3	8	M20 (3/4")	23	6.72	7.75
200	216 (219.1*)	340	24	24	24	295	62	232 235	5.9	10	16	268	3	8	M20 (3/4")	23	9.50	11.3
250	267 (273*)	395	26	26	26	350	68	285 292	6.3	12	16	320	3	12	M20 (3/4")	23	12.5	14.7
300	381 (323.9*)	445	26	26	28	400	68	335 344	7.1	12	16	370	4	12	M20 (3/4")	23	14.4	17.6
350	355.6*) 368	505	26	28	30	460	68	385	7.1	12	16	430	4	16	M20 (3/4")	23	20.6	21.4
400	406.4*) 419	565	26	32	32	515	72	440	7.1	12	16	482	4	16	M24 (7/8")	27	27.9	26.1
500	508*) 521	670	28	38	34	620	75	542	7.1	12	16	585	4	20	M24 (7/8")	27	41.1	34.7
600	609.6*) 622	780	28			725	80	642	7.1	12	18	685	5	20	M27 (1")	30		
700	711.2*) 720	895	30			840	80	754	8.0	12	18	800	5	24	M27 (1")	30		
800	812.8*) 820	1015	32			950	90	850	8.0	12	18	905	5	24	M30 (1.1/8")	30		
900	914.4*) 920	1115	34			1050	95	950	10.0	12	20	1005	5	28	M30 (1.1/8")	33		
1000	1016*) 1020	1230	34			1160	95	1052	10.0	16	20	1110	5	28	M33 (1 1/4")	36		

Out side diameter of pipe complies with ISO recommendation R64



# 16BAR

**DIN 2543 SLIP - ON FLANGES**

**DIN 2527 BLIND FLANGES**

**DIN 2633 WELDING NECK FLANGES**

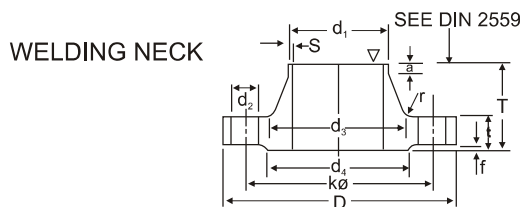

Unit : mm

Bore		Common Dimension					Hub				Raise Face		Drilling			Approx Weight (kg)			
Nominal Bore	d <sub>1</sub>	D	t			K	T	d <sub>3</sub>	s	r	a	d <sub>4</sub>	f	No. of Bolt	Dia. of Bolt		d <sub>2</sub>	DIN 2543	DIN 2633
			Welding neck	slip-on (No-hub)	Blind														
10	14 17.2*)	90	14	14	14	60	35	25 28	1.8	4	6	40	2	4	M12	(1.2")	14	0.63	0.580
15	20 21.3*)	95	14	14	14	65	35	30 32	2.0	4	6	45	2	4	M12	(1.2")	14	0.72	0.648
20	25 26.9*)	105	16	16	16	75	38	38 40	2.3	4	6	58	2	4	M12	(1.2")	14	1.01	0.952
25	30 33.7*)	115	16	16	16	85	38	42 45	2.6	4	6	68	2	4	M12	(1.2")	14	1.23	1.14
32	38 42.4*)	140	16	16	16	100	40	52 56	2.6	6	6	78	2	4	M16	(5/8")	18	1.80	1.69
40	44.5 48.3*)	150	16	16	16	110	42	60 64	2.6	6	7	88	3	4	M16	(5/8")	18	2.09	1.86
50	57 60.3*)	165	18	18	18	125	45	72 75	2.9	6	8	102	3	4	M16	(5/8")	18	2.88	2.53
65	76.1*)	185	18	18	18	145	45	90	2.9	6	10	122	3	4	M16	(5/8")	18	3.66	3.06
80	88.9*)	200	20	20	20	160	50	105	3.2	8	10	138	3	8	M16	(5/8")	18	4.77	3.70
100	108 114.3*)	220	20	20	20	180	52	125 131	3.6	8	12	158	3	8	M16	(5/8")	18	5.65	4.62
125	133 139.7*)	250	22	22	22	210	55	150 156	4.0	8	12	188	3	8	M16	(5/8")	18	8.42	6.30
150	159 168.3*)	285	22	22	22	240	55	175 184	4.5	10	12	212	3	8	M20	(3/4")	23	10.4	7.75
200	216 219.1*)	340	24	24	24	295	62	232 235	5.9	10	16	268	3	12	M20	(3/4")	23	16.1	11.0
250	267 273*)	405	26	26	26	355	70	285 292	6.3	12	16	320	3	12	M24	(7/8")	27	24.9	15.6
300	381 323.9*)	460	28	28	28	410	78	338 344	7.1	12	16	378	4	12	M24	(7/8")	27	35.1	22.0
350	355.6*) 368	520	30	30	30	470	82	390	8.0	12	16	438	4	16	M24	(7/8")	27	47.8	28.7
400	406.4*) 419	580	32	32	32	525	85	445	8.8	12	16	490	4	16	M27	(1")	30	63.5	36.3
500	508*) 521	715	34	36	34	650	90	548	8.0	12	16	610	4	20	M30	(1 1/8")	33	102.0	59.3
600	609.6*) 622	840	36	40		770	95	652	8.8	12	18	725	5	20	M33	(1 1/4")	36		
700	711.2*) 720	910	36			840	100	755	8.8	12	18	795	5	24	M33	(1 1/4")	36		
800	812.8*) 820	1025	38			950	105	855	10.0	12	20	900	5	24	M36	(1 3/8")	39		
900	914.4*) 920	1125	40			1050	110	955	10.0	12	20	1000	5	28	M36	(1 3/8")	39		
1000	1016*) 1020	1255	42			1170	120	1058	10.0	16	20	1115	5	28	M39	(1 1/2")	42		

Out side diameter of pipe complies with ISO recommendation R64



## 25BAR

DIN 2544 SLIP - ON FLANGES

DIN 2527 BLIND FLANGES

DIN 2634 WELDING NECK FLANGES

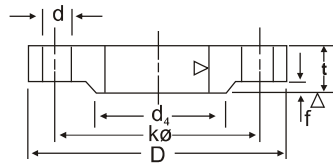

SLIP-ON

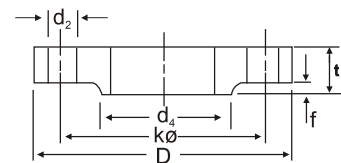

BLIND

Unit : mm

Bore		Common Dimension						Hub				Raise Face		Drilling			Approx Weight (kg)		
Nominal Bore	d <sub>1</sub>	D	t			K	T	d <sub>3</sub>	s	r	a	d <sub>1</sub>	f	No. of Bolt	Dia. of Bolt		d <sub>3</sub>	DIN 2544	DIN 2634
			Welding neck	slip-on (No-hub)	Blind														
10	14 17.2*)	90	16	16	16	60	35	25 28	1.8	4	6	40	2	4	M12	(1.2")	14	0.72	0.661
15	20 21.3*)	95	16	16	16	65	35	30 32	2.0	4	6	45	2	4	M12	(1.2")	14	0.81	0.746
20	25 26.9*)	105	18	18	18	75	40	38 40	2.3	4	6	58	2	4	M12	(1.2")	14	1.24	1.06
25	30 33.7*)	115	18	18	18	85	40	42 46	2.6	4	6	68	2	4	M12	(1.2")	14	1.38	1.29
32	38 42.4*)	140	18	18	18	100	42	52 56	2.6	6	6	78	2	4	M16	(5/8")	18	2.03	1.88
40	44.5 48.3*)	150	18	18	18	110	45	60 64	2.6	6	7	88	3	4	M16	(5/8")	18	2.35	2.34
50	57 60.3*)	165	20	20	20	125	48	72 75	2.9	6	8	102	3	4	M16	(5/8")	18	3.20	2.82
65	76.1*)	185	22	22	22	145	52	90	2.9	6	10	122	3	8	M16	(5/8")	18	4.29	3.74
80	88.9*)	200	24	24	24	160	58	105	3.2	8	12	138	3	8	M16	(5/8")	18	5.88	4.75
100	108 114.3*)	235	24	24	24	190	65	128 134	3.6	8	12	162	3	8	M20	(3/4")	23	7.54	6.52
125	133 139.7*)	270	26	26	26	220	68	155 162	4.0	8	12	188	3	8	M24	(7/8")	27	10.8	9.07
150	159 168.3*)	300	28	28	28	250	75	182 192	4.5	10	12	218	3	8	M24	(7/8")	27	14.5	11.8
200	216 219.1*)	360	30	30	30	310	80	240 244	6.3	10	16	278	3	12	M24	(7/8")	27	22.3	17.0
250	267 273*)	425	32	32	32	370	88	292 298	7.1	12	18	355	3	12	M27	(1")	30	33.5	24.4
300	381 323.9*)	485	34	34	34	430	92	345 352	8.0	12	18	395	4	16	M27	(1")	30	46.3	31.2
350	355.6*)	555	38	38	38	490	100	398	8.0	12	20	450	4	16	M30	(1 1/8")	33	68.0	45.0
400	406.4*)	620	40	40	40	550	110	452	8.8	12	20	505	4	16	M33	(1 1/4")	36	89.7	58.7
500	508*)	730	44	44	44	660	125	558	10.0	12	20	615	4	20	M33	(1 1/4")	36	138.0	86.1
600	609.6*)	845	46			770	125	660	11.0	12	20	720	5	20	M36	(1 3/8")	39		101.0
700	711.2*)	960	46			875	125	760	12.5	12	20	820	5	24	M39	(1 1/2")	42		134.0
800	812.8*)	1085	50			990	135	865	14.2	12	22	930	5	24	M45	(1 3/4")	48		183.0
900	914.4*)	1185	54			1090	145	968	16.0	12	24	1030	5	28	M45	(1 3/4")	48		232.0
1000	1016*)	1320	58			1210	155	1070	17.5	16	24	1140	5	28	M52	(2")	56		302.0

Out side diameter of pipe complies with ISO recommendation R64



## 40BAR

DIN 2545 SLIP - ON FLANGES

DIN 2527 BLIND FLANGES

DIN 2635 WELDING NECK FLANGES

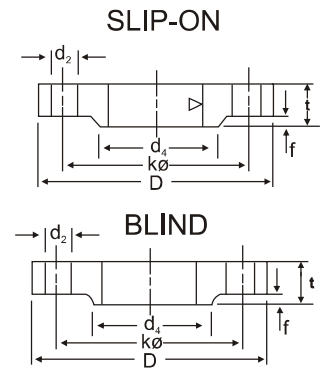
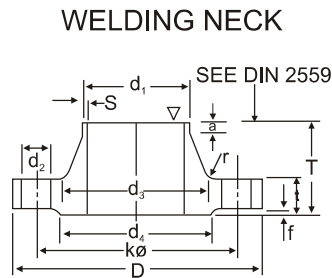

Unit : mm

Bore		Common Dimension					Hub				Raise Face		Drilling			Approx Weight (kg)		
Nominal Bore	d <sub>1</sub>	D	t			K	T	d <sub>3</sub>	s	r	a	d <sub>4</sub>	f	No. of Bolt	Dia. of Bolt	d <sub>2</sub>	DIN 2545	DIN 2635
			Welding neck	slip-on (No-hub)	Blind						≈							
10	14 17.2*)	90	16	16	16	60	35	25 28	1.8	4	6	40	2	4	M12 (1.2")	14	0.72	0.661
15	20 21.3*)	95	16	16	16	65	38	32	2.0	4	6	45	2	4	M12 (1.2")	14	0.81	0.746
20	25 26.9*)	105	18	18	18	75	40	38 40	2.3	4	6	58	2	4	M12 (1.2")	14	1.24	1.06
25	30 33.7*)	115	18	18	18	85	40	42 46	2.6	4	6	68	2	4	M12 (1.2")	14	1.38	1.29
32	38 42.4*)	140	18	18	18	100	42	52 56	2.6	6	6	78	2	4	M16 (5/8")	18	2.03	1.88
40	44.5 48.3*)	150	18	18	18	110	45	60 64	2.6	6	7	88	3	4	M16 (5/8")	18	2.35	2.33
50	57 60.3*)	165	20	20	20	125	48	72 75	2.9	6	8	102	3	4	M16 (5/8")	18	3.20	2.82
65	76.1*)	185	22	22	22	145	52	90	2.9	6	10	122	3	8	M16 (5/8")	18	4.29	3.74
80	88.9*)	200	24	24	24	160	58	105	3.2	8	12	138	3	8	M16 (5/8")	18	5.88	4.75
100	108 114.3*)	235	24	24	24	190	65	128 134	3.6	8	12	162	3	8	M20 (3/4")	23	7.54	6.52
125	133 139.7*)	270	26	26	26	220	68	155 162	4.0	8	12	188	3	8	M24 (7/8")	27	10.8	9.07
150	159 168.3*)	300	28	28	28	250	75	182 192	4.5	10	12	218	3	8	M24 (7/8")	27	14.5	11.80
(175)	(191 193.7*)	350	32	30	32	295	82	251 218	5.6	10	15	260	3	12	M27 (1")	30	22.1	18.2
200	216 291.1*)	375	34	34	34	320	88	240 244	6.3	10	16	385	3	12	M27 (1")	30	27.2	21.5
250	267 273*)	450	38	38	38	385	105	298 306	7.1	12	18	345	3	12	M30 (1 1/8")	33	43.8	34.9
300	318 323.9*)	515	42	42	42	450	115	352 362	8.0	12	18	410	4	16	M30 (1 1/8")	33	63.3	49.7
350	355.6* 368	580	46	46	46	510	125	408	8.8	12	20	565	4	16	M33 (1 1/4")	36	89.5	68.1
400	406.4* 419	660	50	50	50	585	135	462	11.0	12	20	535	4	16	M36 (1 1/8")	39	127.0	96.5
500	508* 521	744	52	52	52	670	140	562	142	12	20	615	4	20	M39 (1 1/8")	42	172.0	117.0

Out side diameter of pipe complies with ISO recommendation R64

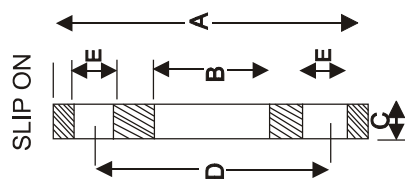

**BS 10 Pipes**

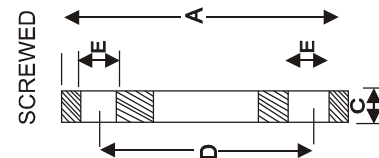
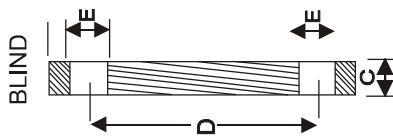

**BS 10 Pipes**

N.B. Size	Table	Dia of Flange A	Bore of Slip-on B	Thickness of Flange C	Pitch circle Dia D (PCD)	Dia of Bolt Holes E	No. of Bolts
1/2"	D	95	22.3	4.7	67	14.3	4
	E	95	22.3	6	67	14.3	4
	F	95	22.3	9.5	67	14.3	4
	H	114	22.3	13	83	17.5	4
3/4"	D	102	27.7	4.7	73	14.3	4
	E	102	27.7	6	73	14.3	4
	F	102	27.7	9.5	73	14.3	4
	H	114	27.7	13	83	17.5	4
1"	D	114	34.6	5	83	14.3	4
	E	114	34.6	7	83	14.3	4
	F	120	34.6	10	87	17.5	4
	H	120	34.6	14	87	17.5	4
1 1/4"	D	120	43.2	6	87	14.3	4
	E	120	43.2	8	87	14.3	4
	F	133	43.2	13	98	17.5	4
	H	133	43.2	17	98	17.5	4
1 1/2"	D	133	49.5	6	98	14.3	4
	E	133	49.5	9	98	14.3	4
	F	140	49.5	13	105	17.5	4
	H	140	49.5	17	105	17.5	4
2"	D	152	62	8	114	17.5	4
	E	152	62	10	114	17.5	4
	F	165	62	16	127	17.5	4
	H	165	62	19	127	17.5	4
2 1/2"	D	165	75	8	127	17.5	4
	E	165	75	10	127	17.5	4
	F	184	75	16	145	17.5	8
	H	184	75	19	145	17.5	8
3"	D	184	90.5	9.5	145	17.5	4
	E	184	90.5	11	145	17.5	4
	F	203	90.5	16	165	17.5	8
	H	203	90.5	22	165	17.5	8
4"	D	215	116	9.5	178	17.5	4
	E	215	116	13	178	17.5	8
	F	228	116	19	191	17.5	8
	H	228	116	25	191	17.5	8
5"	D	254	144	12.7	210	17.5	8
	E	254	144	14	210	17.5	8
	F	279	144	22	235	22.2	8
	H	279	144	25	235	22.2	8

N.B. Size	Table	Dia of Flange A	Bore of Slip-on B	Thickness of Flange C	Pitch circle Dia D	Dia of Bolt Holes E	No. of Bolts
6"	D	279	171	12.7	235	17.5	8
	E	279	171	17	235	22.2	8
	F	305	171	22	260	22.2	12
	H	305	171	29	260	22.2	12
8"	D	336	221.5	13	292	17.5	8
	E	336	221.5	19	292	22.2	8
	F	368	221.5	25	324	22.2	12
	H	368	221.5	32	324	22.2	12
10"	D	406	276.5	16	356	22.2	8
	E	406	276.5	25	356	22.2	12
	F	431	276.5	22	381	25.4	12
	H	431	276.5	35	381	25.4	12
12"	D	457	327	16	406	22.2	12
	E	457	327	29	406	25.4	12
	F	488	327	25	438	25.4	16
	H	488	327	38	438	25.4	16
14"	D	527	359	19	470	25.4	12
	E	527	359	32	470	25.4	12
	F	552	359	25	495	28.7	16
	H	552	359	41	495	28.7	16
16"	D	578	410.5	19	521	25.4	12
	E	578	410.5	32	521	25.4	12
	F	610	410.5	25	552	28.7	20
	H	610	410.5	44	552	32	20
18"	D	641	461.5	22	584	25.4	12
	E	641	461.5	35	584	25.4	16
	F	673	461.5	29	610	32	20
	H	673	461.5	48	610	32	20
20"	D	705	513	25	641	25.4	16
	E	705	513	38	641	25.4	16
	F	737	513	32	673	32	24
	H	737	513	51	673	32	24
24"	D	826	616	29	756	28.7	16
	E	826	616	38	756	32.3	16
	F	851	616	38	781	32	24
	H	851	616	57	781	35	24



### DIMENSIONS OF RAISED FLANGES - AS PER IS :1538 (PART IV) - 1976

N. B	Out Dia	Thickness	Bolt Circle Dia	No. Of Bolt	Dia. Of Holes
80	200	21	160	4	19
100	220	22	180	8	19
125	250	22.5	210	8	19
150	285	23.0	240	8	23
200	340	24.5	295	8	23
250	395	26	350	12	23
300	445	27.5	400	12	23
350	505	29	450	16	23
400	565	30	515	16	28
450	615	31.5	565	20	28
500	670	33	620	20	28
600	780	36	725	20	31
700	895	38.5	840	24	31
750	960	40	900	24	31
800	1015	41.5	950	24	34



## STANDARD FINISH

### STANDARD FINISHES for Face of flange (ANSI B16.5)

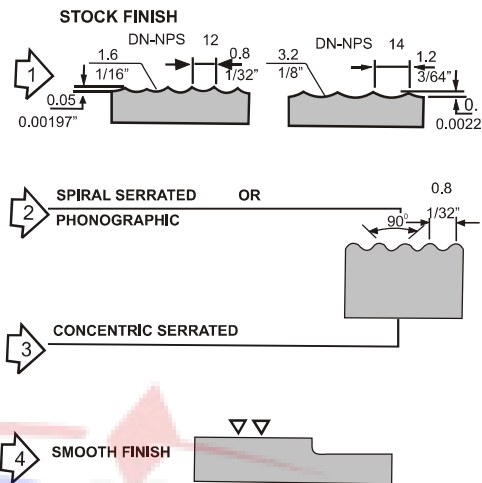
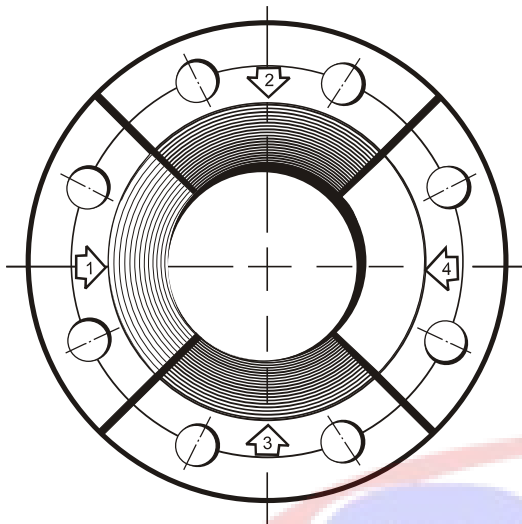

#### STOCK FINISH:

The most widely of any gasket finish, because practically is suitable for all ordinary service conditions. This is a continuous spiral groove. Flanges sizes 12" (304.8mm) and smaller are produced with a 1/16" round-nosed tool at a feed of 1/32" per revolution for sizes 14" (355.6mm) and larger, the finish is made with 1/8" round-nosed tool at a feed of 3/64" per revolution.

#### SPIRAL SERRATED OR PHONOGRAPHIC.

This Finish Is Producing By Using A 90° Round-nosed Tool.

#### CONCENTRIC SERRATED:

This finish is producing by using a 90° round-nosed tool.

#### SMOOTH FINISH:

The Cutting tool employed shall have an approximate 0.06" radius.

The resultant surface finish shall have a 125μ inch to 250μ inch (ANSI B 16.5 para 6.4;4.1)

#### 1. RAISED FACE, AND LARGE MALE AND FEMALE

Either a serrated-concentric or serrated-spiral finish having from 34 to 64 grooves per inch is used,

The Cutting tool employed has an approximate 0.06 in. radius. The resultant surface finish shall have a 125μ (3.2μm) to 500μ inch (12.5μm) approximate roughness.

#### 2. TONGUE AND GROOVE, AND SMALL MALE AND FEMALE

The gasket contact surface does not exceed 125μ in.(3.2μm) roughness

#### 3. RING JOINT

The inside wall surface of gasket groove does not exceed 63μ in.(16.μm) roughness.

#### 4. BLIND

Blind flanges need not be face in the center if, when this center part is raised, its diameter is at least 1 in.

smaller than the inside diameter of fittings of the corresponding pressure class. When the center part is depressed, its diameter is not greater than the inside diameter of the corresponding pressure class fittings. Machining of the depressed center is not required.





## DIMENSIONAL TOLERANCES OF FORGED FLANGES ANSI B 16.5

### Welding Neck

### Threaded, Slipon, Lapjoint, Socket Welding & Blind

Outside Diameter	O.D. is 600 or smaller O. D. over 600	$\pm 1.6$ $\pm 3.1$	Outside Diameter	O.D. is 50 or smaller O. D. over 600	$\pm 1.6$ $\pm 3.1$
Inside Diameter (bore)	250 and smaller 12 through 450 500 and larger	$\pm 0.7$ $\pm 1.6$ $\pm 3.1$	Inside Diameter slip lap joint:	threaded: to standard gauge limits socket-welding: 250 and larger 300 and larger	(bore)  $+0.7$ $-0.0$ $+1.6$ $-0.0$
Diameter of contact face	1.6 raise face 6.3 raised face: tongue & grooved male & female	$\pm 0.7$ $\pm 0.4$	Diameter of counter bore	threaded 250 and smaller 300 and larger	$+0.7$ $-0.0$ $+1.6$ $-0.0$
Diameter of hub at base	When E is 600 or smaller When E is over 600	$\pm 1.6$ $\pm 3.1$	Outside diameter hub	300 and smaller 350 and larger	$+2.3$ $-1.6$ $\pm 3.1$
Diameter hub at point of welding	125 and smaller 150 and larger	$+0.7$ $\pm 0.7$ $+4.0$ $\pm 0.0$	Diameter of contact face	1.6 raised face 6.3 raised: tongue & grooved male & female	$\pm 0.7$ $\pm 0.4$
Thickness	450 and smaller 500 and larger	$+3.1$ $\pm 0.0$ $+4.7$ $\pm 0.0$	Thickness	450 and smaller 500 and larger	$+3.1$ $-0.0$ $+4.7$ $-0.0$
Length through hub	250 and smaller 300 and larger	$\pm 1.6$ $\pm 3.1$	Length through hub	250 and smaller 300 and larger	$\pm 1.6$ $\pm 3.1$
Drilling	bolt circle bolt hole spacing	$\pm 1.6$ $\pm 0.7$	Drilling	bolt circle bolt hole spacing	$\pm 1.6$ $\pm 0.7$
	essentricity with respect to bore	0.7 max		essentricity with respect to bore	0.7 max

### WELDING NECK FLANGE BORE

NPS (NB)	O.D. (MM)	Sch. 10	Sch. 20	Sch. 30	Sch. Std	Sch. 40	Sch. XS	Sch. 80	Sch. 120	Sch. 160	Sch. XXS
15	21.33	17.1	-	-	15.7	15.7	13.8	13.8	-	11.7	6.4
20	26.67	22.5	-	-	20.8	20.8	18.8	18.8	-	15.5	11.0
25	33.40	27.9	-	-	26.6	25.4	24.3	24.3	-	20.7	15.2
32	42.16	36.6	-	-	35.0	35.0	32.4	32.4	-	29.4	22.7
40	48.26	42.7	-	-	40.8	40.8	38.1	38.1	-	33.7	27.9
50	60.31	54.8	-	-	52.3	52.3	49.2	49.2	-	42.8	38.1
65	73.02	66.9	-	-	62.4	62.4	59.0	59.0	-	53.9	44.9
80	88.90	82.8	-	-	77.9	77.9	73.6	73.6	-	66.6	58.4
100	114.30	108.2	-	-	102.2	102.2	97.1	97.1	92.0	87.3	80.0
125	141.30	134.5	-	-	128.1	128.1	122.2	122.2	115.9	109.5	103.2
150	168.27	161.5	-	-	154.0	154.0	146.3	146.3	139.7	131.7	124.3
200	219.07	211.6	206.2	204.9	202.7	202.7	193.6	193.6	182.5	173.0	174.6
250	273.05	264.7	260.3	257.4	254.5	254.5	247.6	242.8	230.1	215.9	222.2
300	323.85	314.7	311.1	307.0	304.8	303.2	298.4	288.8	273.0	257.2	273.0
350	355.60	346.2	337.8	336.5	336.5	333.3	330.2	317.5	300.0	284.1	-
400	406.40	396.7	390.3	387.3	387.3	381.0	381.0	363.5	344.5	325.4	-
450	457.20	447.5	441.1	434.9	438.1	428.6	431.8	409.5	387.3	366.7	-
500	508.00	497.3	488.9	482.6	488.9	477.8	482.6	455.6	431.8	407.9	-
600	609.60	596.9	590.5	581.0	590.5	574.6	584.2	547.6	517.5	490.5	-



## ANSI FLANGES WEIGHT (KGS)

Nom Pipe Size	150#			300#			600#			900#			1500#			2500#		
	WN	S/O	B/K	WN	S/O	B/K	WN	S/O	B/K	WN	S/O	B/K	WN	S/O	B/K	WN	S/O	B/K
1/2"	0.7	0.4	0.5	0.8	0.7	0.8	0.9	0.8	0.8	2.1	1.8	1.9	2.1	1.8	1.9	3.2	3	3
3/4"	0.8	0.7	0.8	1.4	1.2	1.2	1.6	1.4	1.4	2.7	2.4	2.7	2.7	2.4	2.7	3.6	4	4.5
1"	1.1	0.8	0.9	1.7	1.4	1.5	1.9	1.7	1.7	3.9	3.6	3.7	3.9	3.6	3.7	5.4	5	5
1.1/4"	1.5	1.2	1.3	2.2	1.8	2	2.6	2.1	2.4	4.5	4.1	4.3	4.5	4.1	4.3	7.8	8	8
1.1/2"	1.8	1.4	1.6	3.2	2.7	2.9	3.6	3.1	3.4	6.2	5.4	5.9	6.2	5.4	5.9	11.5	11	11
2"	2.7	2.2	2.6	3.6	3.2	3.5	4.7	3.9	4.4	11.3	10.5	11.3	11.3	10.5	11.3	19	17	17
2.1/2"	4.4	3.5	4.1	5.4	4.5	5.3	4.8	5.4	6.8	16.3	15.8	16	16.3	15.8	16	24	25	25
3"	5.2	3.8	5.1	7.3	5.9	7.2	8.7	7.3	8.9	15	12.3	16.8	21	21.5	19.5	42.6	38	39
3.1/2"	6.4	5	6.5	8.9	7.5	9.2	11.6	9	12.7	-	-	-	-	-	-	-	-	-
4"	7.5	5.6	7.5	11.8	10	12.2	18.4	16.5	18.6	24	23.2	24.5	31.8	31	33	64	58	60
5"	9.2	6.5	9.2	16	12.5	16	31	28.5	30.8	38.5	37.5	39.5	59	58.8	60	111	95	101
6"	11.0	8.1	11.8	20.2	16.5	22	37	36.2	38	50	48.3	51.5	72	74	75	171	146	156
8"	18.4	13	20.4	31.2	25.5	36	54.5	51.5	62.2	85	75	89	124	112	125	261	220	242
10"	25.5	18.4	31	44.3	35	55	98.5	76.2	102	123	110	131	207	184	215	485	420	465
12"	37	28.5	47	63.5	52	82.5	105	89.5	132	168	146	187	306	264	316	698	590	665
14"	51	37.5	60	86	73	108	150	102	158	198	172	224	416	-	-	-	-	-
16"	61.5	44.5	61	112	88	139	177	150	225	225	192	259	567	-	-	-	-	-
18"	71.5	54	93	141	115	178	228	180	285	318	272	383	736	-	-	-	-	-
20"	85	72	127	173	139	228	285	231	365	376	330	482	929	-	-	-	-	-
24"	119	95	190	248	212	350	372	330	532	680	632	905	1504	-	-	-	-	-



### Bolt and Stud Dimensions ASME B 16.5

Nominal Pipe Size	150 LB. Flanges				300 LB. Flanges				600 LB. Flanges			
	# Bolts or Studs	Dia of Bolts or Studs	Length of Stud		# Bolts or Studs	Dia of Bolts or Studs	Length of Stud		# Bolts or Studs	Dia of Bolts or Studs	Length of Stud	
			1/16 RF	RTJ			1/16 RF	RTJ			1/4 RF	RTJ
1/2	4	0.50	2-1/4	-	4	0.50	2 1/2	3	4	0.50	3	3
3/4	4	0.50	2-1/2	-	4	0.63	3	3-1/2	4	0.63	3-1/2	3-1/2
1	4	0.50	2-1/2	3	4	0.63	3	3-1/2	4	0.63	3-1/2	3-1/2
1-1/4	4	0.50	2-3/4	3-1/4	4	0.63	3-1/4	3-3/4	4	0.63	3-3/4	3-3/4
1-1/2	4	0.50	2-3/4	3-1/4	4	0.75	3-1/2	4	4	0.75	4-1/4	4-1/4
2	4	0.63	3-1/4	3-3/4	8	0.63	3-1/2	4	8	0.63	4-1/4	4-1/4
2-1/2	4	0.63	3-1/2	4	8	0.75	4	4-1/2	8	0.75	4-3/4	4-3/4
3	4	0.63	3-1/2	4	8	0.75	4-1/4	4-3/4	8	0.75	5	5
3-1/2	8	0.63	3-1/2	4	8	0.75	4-1/4	5	8	0.88	5-1/2	5-1/2
4	8	0.63	3-1/2	4	8	0.75	4-1/2	5	8	0.88	5-3/4	5-3/4
5	8	0.75	3-3/4	4-1/4	8	0.75	4-3/4	5-1/4	8	1.00	6-1/2	6-1/2
6	8	0.75	4	4-1/2	12	0.75	4-3/4	5-1/2	12	1.00	6-3/4	6-3/4
8	8	0.75	4-1/4	4-3/4	12	0.88	5-1/2	6	12	1.13	7-1/2	7-3/4
10	12	0.88	4-1/2	5	16	1.00	6-1/4	6-3/4	16	1.25	8-1/2	8-1/2
12	12	0.88	4-3/4	5-1/4	16	1.13	6-3/4	7-1/4	20	1.25	8-3/4	8-3/4
14	12	1.00	5-1/4	5-3/4	20	1.13	7	7-1/2	20	1.38	9-1/4	9-1/4
16	16	1.00	5-1/4	5-3/4	20	1.25	7-1/2	8	20	1.50	10	10
18	16	1.13	5-3/4	6-1/4	24	1.25	7-3/4	8-1/4	20	1.63	10-3/4	10-3/4
20	20	1.13	6-1/4	6-3/4	24	1.25	8	8-3/4	24	1.63	11-1/4	11-1/2
24	20	1.25	6-3/4	7-1/4	24	1.50	9	10	24	1.88	13	13-1/4

Nominal Pipe Size	900 LB. Flanges				1500 LB. Flanges				2500 LB. Flanges			
	# Bolts or Studs	Dia of Bolts or Studs	Length of Stud		# Bolts or Studs	Dia of Bolts or Studs	Length of Stud		# Bolts or Studs	Dia of Bolts or Studs	Length of Stud	
			1/4 RF	RTJ			1/4 RF	RTJ			1/4 RF	RTJ
1/2	4	0.75	4-1/4	4-1/4	4	0.75	4-1/4	4-1/4	4	0.75	4 3/4	4 3/4
3/4	4	0.75	4-1/2	4-1/2	4	0.75	4-1/2	4-1/2	4	0.75	5	5
1	4	0.88	5	5	4	0.88	5	5	4	0.88	5-1/2	5-1/2
1-1/4	4	0.88	5	5	4	0.88	5	5	4	1.00	6	6
1-1/2	4	1.00	5-1/2	5-1/2	4	1.00	5-1/2	5-1/2	4	1.13	6	6
2	8	0.88	5-3/4	5-3/4	8	0.88	5-3/4	5-3/4	8	1.00	7	7
2-1/2	8	1.00	6-1/4	6-1/4	8	1.00	6-1/4	6-1/4	8	1.13	7-3/4	8
3	8	0.88	5-3/4	5-3/4	8	1.13	7	7	8	1.25	8-3/4	9
4	8	1.13	6-3/4	6-3/4	8	1.25	7-3/4	7-3/4	8	1.50	10	10-1/4
5	8	1.25	7-1/2	7-1/2	8	1.50	9-3/4	9-3/4	8	1.75	11-3/4	12-1/4
6	12	1.13	7-1/2	7-3/4	12	1.38	10-1/4	10-1/2	8	2.00	13-1/2	14
8	12	1.38	8-3/4	8-3/4	12	1.63	11-1/2	12-3/4	12	2.00	15	15-1/2
10	16	1.38	9-1/4	9-1/4	12	1.88	12-1/4	12-1/2	12	2.50	19-1/4	20
12	20	1.38	10	10	16	2.00	14-3/4	15-1/4	12	2.75	21-1/4	22
14	20	1.50	10-3/4	11	16	2.25	16	16-3/4	-	-	-	-
16	20	1.63	11-1/4	11-1/4	16	2.50	17-1/2	18-1/2	-	-	-	-
18	20	1.88	12-3/4	13-1/4	16	2.75	19-1/2	20-3/4	-	-	-	-
20	20	2.00	13-3/4	14-1/4	16	3.00	21-1/4	22-1/4	-	-	-	-
24	20	2.50	17-1/4	18	16	3.50	24-1/4	25-1/2	-	-	-	-

Dimensions are in inches

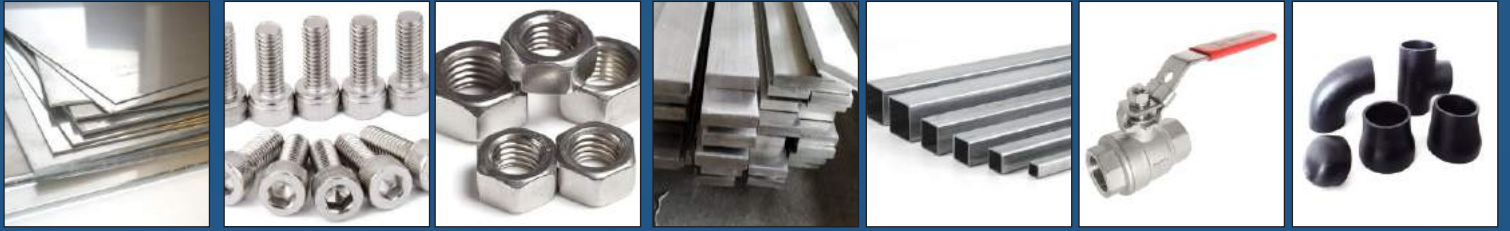

## APPLICATION INDUSTRIES

- Textile Industries
- Cement Industries
- Paper & Pulp Mills
- Sugar Industries
- Water Piping Systems
- Refinery Plants
- Power Plant
- Chemical & Fertilizers
- Beverage Industries
- Pharmacy Industries
- Food Industries
- Oil & Gas Industries

We are one of the leading manufacturer, Exporter & well Diversified Groups supplying to more than 90 countries dealing in Stainless Steel, Carbon Steel & Alloy Steel Since 1991.



# SACHIYA STEEL INTERNATIONAL

(A HUB OF QUALITY)

MANUFACTURERS OF :

TUBES | PIPES | PIPE FITTINGS | FORGED FITTINGS | FLANGES | FASTENERS

IN STAINLESS STEEL | MILD STEEL | NICKEL ALLOYS | ALUMINIUM ALLOYS

INCO ALLOYS | TITANIUM ALLOYS | SQUARE PIPES | SHEETS | SQUARE RODS | ROUND BARS | HEX BARS

**Head Office :**

D-3, Ground Flr, Bharat Nagar Society, Grant Road (E), Mumbai-400007

Tel No.: 022-66518863 | Mob.: +91 9769056007 | Mob.: +91 9137972560

E-mail : [sales@sachiyasteel.com](mailto:sales@sachiyasteel.com) | [export@sachiyasteel.com](mailto:export@sachiyasteel.com) | [connectsachiyasteel@gmail.com](mailto:connectsachiyasteel@gmail.com)

Website : [www.sachiyasteel.com](http://www.sachiyasteel.com)