



MFG: OVERHEAD ELECTRICAL CRANE CONTROL SYSTEM

OUR CORE PURPOSE
 TO MAXIMIZE THE GROWTH OF PEOPLE BY PROVIDING TECHNOLOGICAL AND CUSTOMIZED SOLUTIONS BY UPLIFTING THEIR ETHOS TO INCREASE THEIR PRODUCTIVITY

OUR CORE VALUES
 » COMMITMENT » TRANSPARENCY
 » INNOVATION AND IMPROVEMENT
 » NO COMPROMISE WITH QUALITY
 » RESPECT TO ALL



PRODUCT RANGE

- » Electro Hydraulic Thruster Brake
- » AC Solenoid brake
- » DSL System (Shrouded Busbar System)
- » EOT Crane Limit switches
- » Anti Collision Device
- » Master Controller
- » C Rail festoon system
- » Busbar System
- » DSL indicating Lamp
- » Wireless Radio remote
- » Punch Grid Resistance Box
- » Pendant Push Button Station
- » Cable Trolley
- » Current Collector
- » Electric Wire Rope Hoist
- » End Carriage System
- » Cable Reeling Drum
- » Gear Coupling
- » Brake Drum Coupling
- » Electro Magnetic Disc Brake

MFG.BY:
GUNATIT ELECTROPOWER PVT. LTD.

E : sales.gepl2010@gmail.com P : +91 99047 82878 A : Plot No.38, Akshat Industrial Area,
 W : www.gunatitelectropower.in M : +91 7990845584 Vil. Ravki, Rajkot-360004 (Guj.) India.
 M : +91 8799046793

www.gunatitelectropower.in

MANUFACTURER OF
CRANE CONTROL EQUIPMENTS



COMPANY PROFILE

We, Gunatit Electropower Private Limited are an ISO 9001:2015 certified company, executing all the business operations in a streamlined manner. We undertake every possible measure to make sure that only defect free products are offered to the buyers. Known as one of the leading Manufacturers, Exporters and Suppliers, we strive to establish long term relation with our valued clients. Our comprehensive range of Products are Thruster Brake, Shrouded DSL Busbar, Punch Grid Resistance Box, C-Rail Festoon System, Master Controller, Rotary Geared Limit Switch, Push Button Pendent Station, Worm Drive Limit Switch, Weight Operated Limit Switch, Radio Remote control, Festoon Cable, Pendent Cable, Cable Trolleys, etc. These are in compliance with the superior industrial and international standards of quality.



THE CONTENT

EOT CRANES	03
ELECTRIC ROPE HOISTS / END CARRIAGE	04
CRANE LIMIT SWITCH	05
CRANE BRAKES	06
DSL/FESTOON	07
CONTROL EQUIPMENTS	08
BRAKE DRUM / CRD / ENCLOSED BUS BAR	09
CRANE REMOTE	10

CRANE

We are engaged in offering a broad range of material lifting cranes such as EOT Cranes which is highly appreciated for low maintenance cost and longer service life. EOT Cranes are well known for their reliable operations, durable finish standards and genuine quality. Due to its quality features, it finds its application in the areas like railway workshops, boat manufacturing and glass handling. The crane is also used for lifting structure steels in construction sites. We use premium quality of stainless steel, procured from reliable vendors, for fabricating equipment.

Single Girder EOT Cranes | Double Girder EOT Cranes | Heavy Duty EOT Cranes with Main & Auxiliary Hoists | Jib Crane
Gantry Cranes End Carriage | Crab | Gears | Rope Drum | Rope Guide



ELECTRIC WIRE ROPE HOISTS

Our organization deals in an advanced and extremely reliable range of electric wire rope hoists, which has trouble-free performance and is sturdy in design. Fabricated using latest technology that represents a revolutionary new generation of exceptionally reliable electric wire hoists. Our expert engineers design an innovative hoist range, featuring advanced technology and breakthrough performance.

» Available Range : 500kg to 10 ton

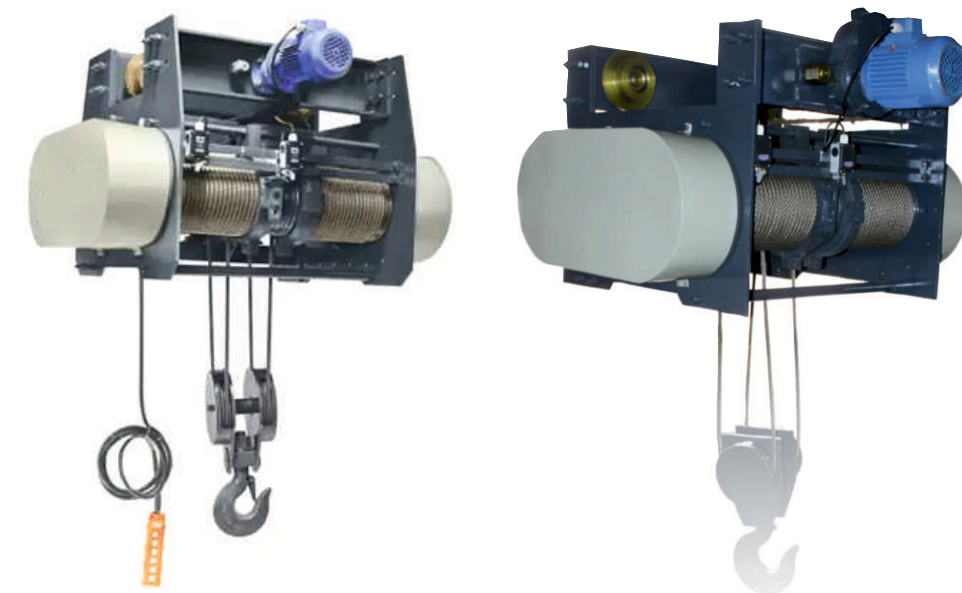

END CARRIAGE

The end carriage beam is a complete driving unit for overhead crane traveling, which is connected with the crane main beam. This carriage beam is also with box girder design with motor, reducer, wheels as a piece of a full set equipment.



Open Reduction Type

L-Block Type



ROTARY GEARED LIMIT SWITCHES (GRLS)

Rotary geared type limit switches are used on control circuit of reversing drivers so as to limit their rotation / movement with a pre-determined position. suitable for use on reversing drives, such as Hoists, Winches, Rolling Mills, various Other mechanisms used in steel plants such as cock oven, Feeding machinery, etc.

- » Steel Sheet Body-IP41
- » Aluminium Body-IP54



WEIGHT OPERATED LIMIT SWITCH (CWLS)

Weight Operated Limit Switches (Counter Weight or Gravity) are used for Heavy duty E.O.T. Cranes, Hoists to prevent over travel of hoisting motion on power and control circuit up to 500v.a.c. and 40 Amps. continuous current. When the Snatch Block of the crane reaches its top position the snatch block pushes a plate which is hanging from one end of the Lever of the Limit Switch. Due to The weight placed on the other end of the lever this lever is pushed up and shaft this lever is connected rotates there by rotating the cams which eventually open the contacts and

- » Steel Sheet Body-IP41
- » Aluminium Body-IP54 (10 & 40 Amps.)



LEVER TYPE LIMIT SWITCH (LLS)

Lever Limit Switches are used for Heavy duty E.O.T. Cranes, Hoists to prevent over Travel of hoisting motion on power and control circuit up to 500V and 40Amps. Continuous current. The Limit switch normally remains closed and cuts off power to stop the motor of the crane. The Lever limit switch operates when it reaches predetermined position when the lever is moved over a projecting member fixed on the girder.

- » Steel Sheet Body-IP41
- » Aluminium Body-IP54 (10 & 40 Amps.)



WORM DRIVE LIMIT SWITCHES (FG)

The new range of limit switches FG has been designed & manufactured according to safety standard are suitable for use on reversing drives. The driving motion is transmitted by worm gear. All gears and hubs are made of low wear thermoplastic. The rotational movements are transmitted to switches by adjustable cams each lever has a single micro metric register screw. This screw exclusively works on its own combined lever, excluding any mechanical.

- » FG12.5P2, FG25P2, FG50P2, FG100P2, FG200P2, FG400P2
- » FG50P4, FG100P4

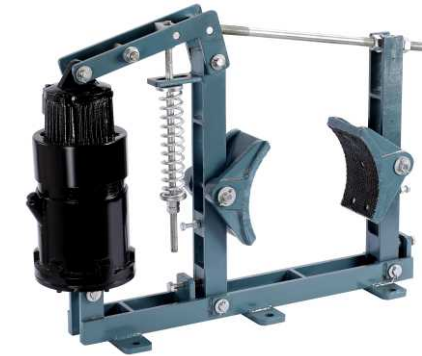

THRUSTER OPERATED BRAKES

Thruster brakes are suitable for 400/440volts, 3 Phase, 50C/s, A.C. Supply. Brake Drum Diameter-100-400mm. Braking torque-6Kg. M.-190 Kg.M. Easy installation & maintenance Reverse action version available Self adjusting lining wear mechanism Hydraulic actuator.



AC SOLENOID BRAKE

AC Solenoid Brake that are suitable for AC Supply up to 400 to 440 volts, and are available for a wide range of drum sizes from 100mm to 250mm Dia. we stand in the midst of prominent electromagnetic brakes suppliers based in India. Since these brakes are in normally closed position, the release of the brake shoes is affected by energizing the electro magnetic coil, which overcomes the spring force and the shoes are moved clear off the drum lever arm linkage system so that the drum is free to rotate without any friction.

These brakes are specially designed

- » To work trouble free & Easy installation
- » To absorb shocks and with stands class'F' insulation
- » To operate in low spring pressure to make long life of friction liner shoes.
- » Size: SSB 4,SSB 5.5, SSB 7, SSB 10



ELECTRO MAGNETIC DISC BRAKE

Electro Magnetic Disc Brake Offered by us has a high class insulation coil, a good quality liner plate and a thick liner. when electric supply is given, the brake is released and the shaft free to rotate in case of power failure or cut off, the brake is instantaneously applied. Brake motor is combination of three phase squirrel cage induction motor with failsafe Brake when power is switched off with ordinary motor, the rotating part will stopped after some time but if brake motor is used rotating mass will stop instantaneously. all brakes are mounted at non-driving end of motor, braking disc is mounted directly on motor shaft. liner plate is only wearing part and this is easily replaceable

RANGE: EP-130 / EP-140 / EP-150 / EP-150X / EP-190 / EP-190X
EP-235 / EP-235X / EP-290 / EP-290 / EP-290XX

CRANE BRAKE PARTS



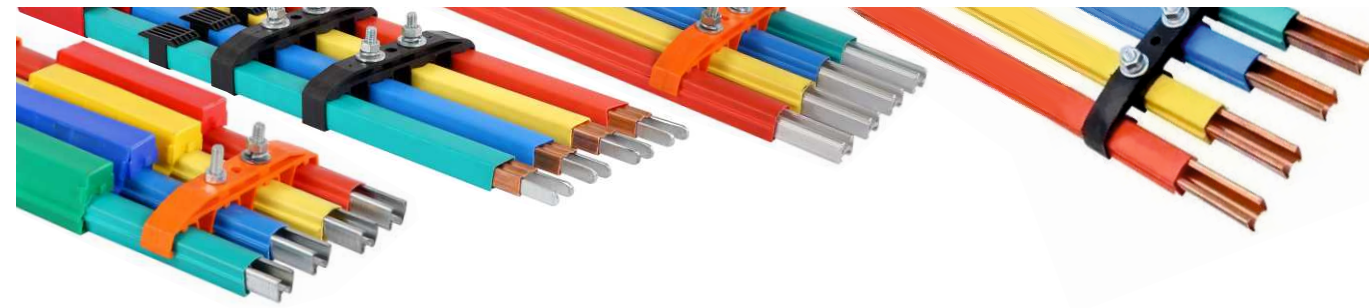

SHROUDED BUSBAR(DSL) SYSTEM

Conductor bars are used for power transmission Conductor bar provide a safe & economical supply of electric power for track guided Mobile machinery. single pole individually insulated conductors. ideally used for EOT Cranes etc. 100-1200 Amps. ratings.

- » Touch proof, no exposed live part Quick & easy installation.
- » Bolted joint Suitable for indoor/Outdoor installation
- » 1 pole / 4 Pole Hanger No Expansion Joints up to 150 meters
- » Insulating cover shaped to shed from water & dust
- » Track Configuration: Straight or Curved 60 to 400 Amps.
- » Conductor in same standard & GI, Aluminum and Copper Material.

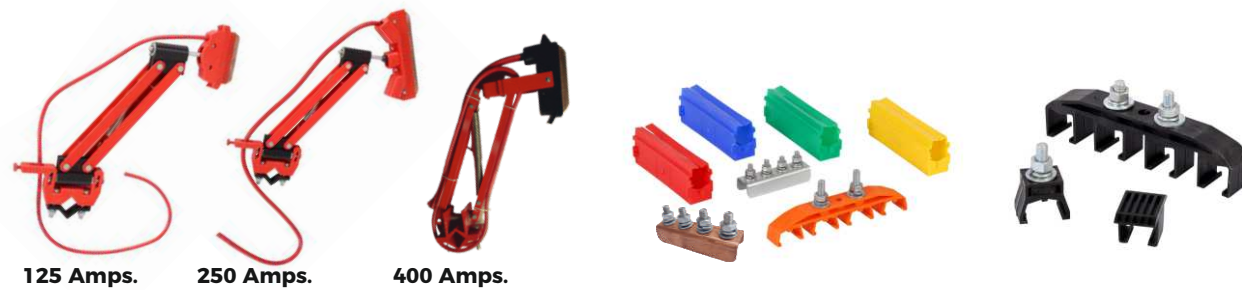

C-RAIL FESTOON SYSTEM

Festoon System are used to electrify various types of mobile equipment. They can be designed not only to support and protect flat and round electrical cables, but air and water hoses as well. Festoon systems are typically used on overhead cranes, port cranes, refuse cranes and other material handling applications. We also have a solution for extremely corrosive environments. Our product range includes non-rusting, acid-proof, and seawater-resistant festoon cable systems, as well as accessories for the various cable management systems.

- » 30x32
- » 40x40



RESISTANCE BOX

Resistor are designed to meet requirement of both A.C. & D.C. application for E.O.T. cranes, winches, rubber mills coal mines, power plants, conveyors etc. for developing starting torques of motors resistors are manufactured.

Air cooled type Punched Steel Grids Resistors :

Punched Grid Resistor consists of grids punched from corrosion resisting nickel chromium alloy sheet steels. the punched steel grids are completely immune to shock & vibration. they function reliably under the worst operating conditions and are particularly suited for steel mill duty. These resistors are available in wide range of current ratings from 8 to 800 amps. continuous with single & multiple parallel paths.

Stainless Steel Grid Resistors:

These Resistors consists of stainless steel wires or strip in form of grids, the current rating generally ranges from 7 to 400 amps continuous with multiple or single paths.



MASTER CONTROLLER

Master controllers are of cam type where in contracts are actuated by individual cams mounted on operated shaft. These controllers are used for remote operation of contractors equipment controlling heavy duty E.O.T. cranes & rolling mill drives Master controller is housed in enclosure and provided with an easily removable cover with ample area for maintenance. The cam shaft is mounted on bearing bushes spindle switch is moved by handle. The cams are cut correspond to the switching program.

- » Steel Sheet Body-IP41
- » Aluminium Body-IP54

ANTI CRANE COLLISION SWITCH



Anti Crane Collision switch for two over head cranes on the same rail. These units are installed on two cranes on the same rail approaching each other. with these units, the two cranes on the same rail will never collide with each other & thus the damage caused due to collision can be saved. the minimum distance in between two cranes will always be maintained, and the cranes will be able to move away from each other but not closer.

- » Supply Voltage : 110 V AC or 220 V AC (User Selectable)
- » Laser Alignment tool : Provided for Alignment of sensor and reflector
- » Output : Potential Free Relay Contacts
- » Contacts Rating : 5 Amps (max.) at 220 V AC
- » Output connections : Through Terminal Strip
- » Range Adjustment : 0 to 10 Mtrs.
- » housing : Metal/PVC Housing

CABLE TROLLEY

- » Suitable For Beam Size from 40mm to 150mm



CABLE CARRIER

- » Suitable For Wire Rope Size from 3mm to 15mm
- » Plastic Body & Metal Body Both Available

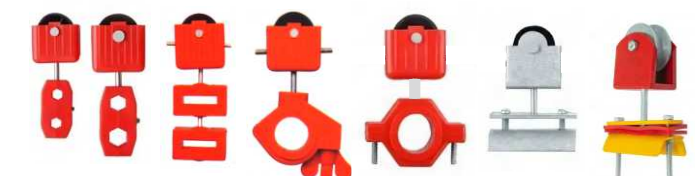

BRAKE DRUMS

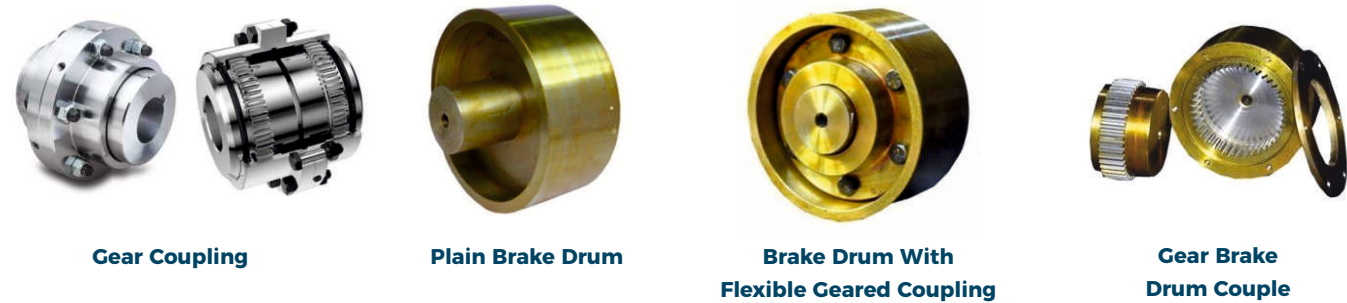

Gear Coupling

Plain Brake Drum

Brake Drum With Flexible Geared Coupling

Gear Brake Drum Couple

CABLE REELING DRUMS

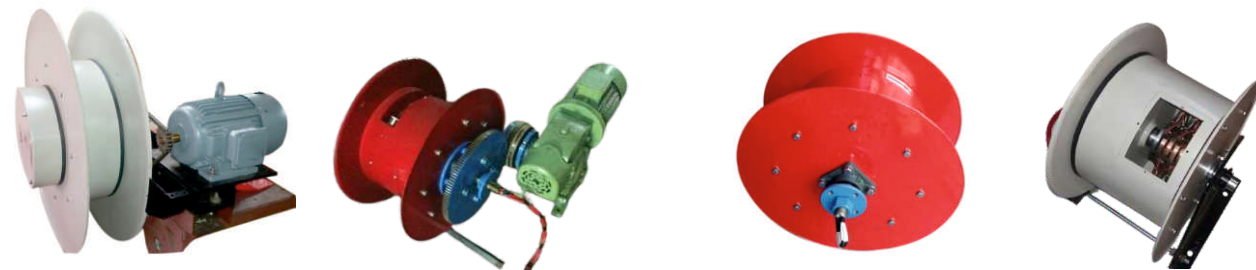

Motorised CRD

Spring Operated CRD

SAFELEAD-4 ENCLOSED CONDUCTOR BAR

The enclosed conductor system are modern and safe system for power energy and data transmission for various types of equipment such as cranes, bridge cranes, conveyors belts, chain conveyors and all moving machineries.



MODEL NO.	TR60-40A	TR60-60A	TR85-40A	TR85-70A	TR85-100A	TR85-140A
Material	COPPER					
Conductor Rating AT +35°C	40A	60A	40A	70A	100A	140A
Impedence Ohms/M 10° +35°C	17.9	11.38	18.36	11.01	7.87	5.55
Resistance Ohms/M 10° +35°C	17	11.33	18.27	10.96	7.83	5.48
Copper Strip Section[mm]	10	15	9.3	15.5	21.7	31

SAFELEAD-4 SPARES



Joint Cover

Hanger Clamp

End Power Feed

End Cap

Towing Arm

25 A Current Collector

35 A Current Collector

70 A Current Collector

Joint Cover Steel

Hanger Clamp Steel

Copper Shoe

Central power Feed

PENDANT PUSH BUTTON STATION

- » Available Range : From 2 Buttons to 14 Buttons
- » Available Range : From 2 Buttons to 14 Buttons



WIRELESS RADIO REMOTE CONTROL

The Radio Remote Control of Gunatit Electro Power Pvt. Ltd. is ideal for EOT cranes, Tower Cranes and other industrial Machinery. The Range of Radio Remote Control is designed to enable wide variety of industrial applications. it enables the operator to work in extreme conditions with ease and hence provides greater safety. The rugged design of transmitter allows the possibility to incorporate single depression push buttons as per requirement. The Receiver will be supplied with 2.5 meter Cable and can be fixed near the panel. The receiver is of Nylon Fiber.

Best Suited for uninterrupted radio signals | No possibility of signal being grounded | lightweight but more sturdy | Very easy to handle and install No corrosion, Aesthetic look | Dust Proof

- » Available Range : From 2 Buttons to 14 Buttons
- » Range of each Remote up to 100 meters

