



Packaging Machinery made for you



半自动缠绕机系列

Semi Automatic Wrapper

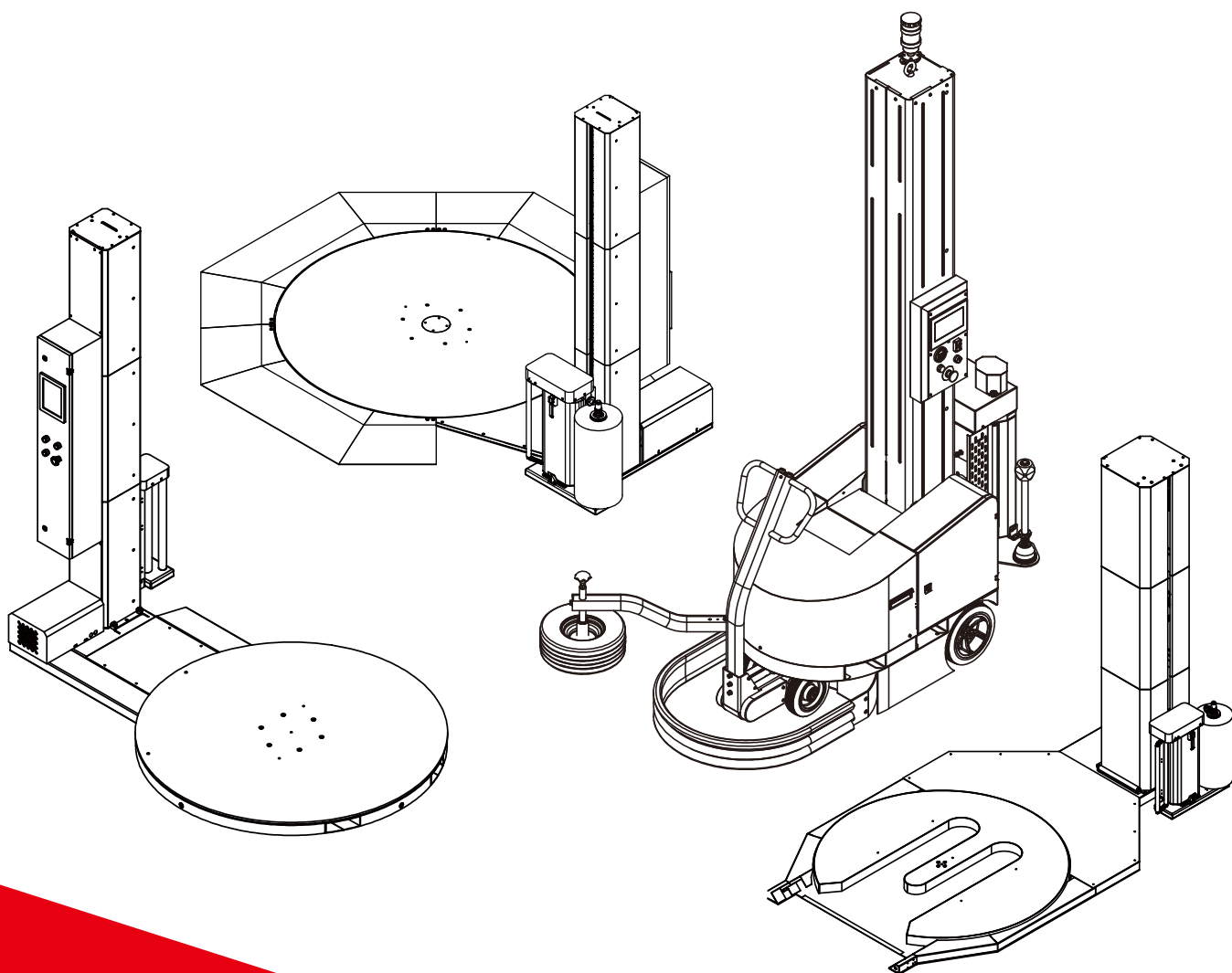

www.earflappack.com

易尔富来普智能设备(嘉兴)有限公司
Earflap Intelligent Equipment (Jiaxing) Co., Ltd



Robust · Easy Running · 24/7 Uptime

European Technology Perfection Crafted with Chinese Ingenuity

The King of Cost-Effectiveness

欧洲技术精粹 中国匠心质造 性价比之王的完美演绎!



省空间 提升集装箱运输装载量 40%

Save Space Increase Container Transport Capacity by 40%



省膜材 系列预拉伸膜架 预拉伸 100%-400%

Save Film Series of Pre-stretch Carriage Pre-stretch Ratio 100%-400%



省人工 易用易安装 触屏可视化图标 一键操作

Save Labor User-Friendly & Easy to Install, Touchscreen Visual Icons, One-Touch Operation



省保养 国际品牌配件 中国先进加工供应链保障

Save Maintenance Premium International Components China's Advanced Supply Chain Assurance

About EARFLAP | 关于易尔富来普

- 由意大利和西班牙EAR-FLAP公司在中国共同创办
- 专注于饮料和液态食品等整线后道智能包装设备研发、制造和一站式集成方案
- 核心技术源自欧洲,公司拥有强大的研发和中国生产、售后服务团队
- Co-founded in China by Italian and Spanish Company EAR-FLAP
- Focus on Beverage and Liquid Food End-of-line Packaging, Particularly Good at R&D, Manufacturing and One-stop Integration Solution
- The Core Technology Comes From Europe, and We Have an Experienced R&D and Chinese Manufacture and After-Sale Service Team

*Packaging
focused*

Standard Turntable Wrapper

标准型转盘缠绕机

6 Wrapping Models 种缠绕方式

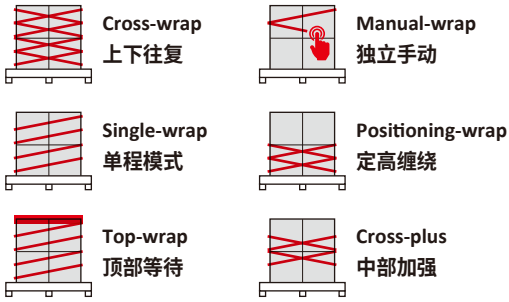

8 Optional & Accessories 种可选配件和功能

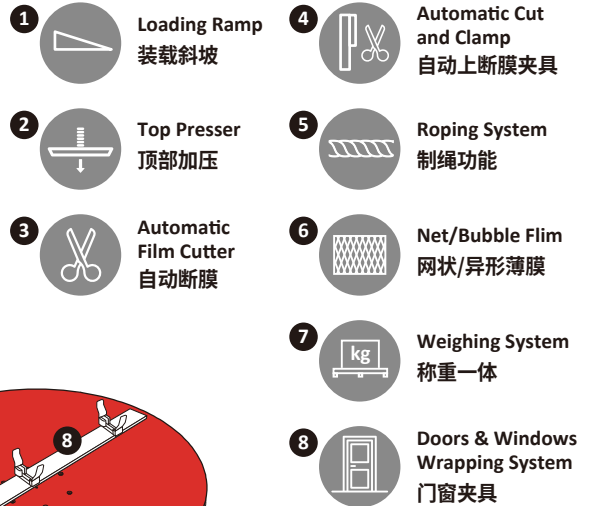

与顶部加压配合使用, 最大承重1000kg
Use with Top Presser, max. loading weight is 1000kg

Technical Data 技术参数

	Standard Turntable Wrapper 标准型转盘缠绕机 (小立柱)	Model 型号 EF-CRT-S15022-DC	Standard Turntable Wrapper 标准型转盘缠绕机 (大立柱)	Model 型号 EF-CRT-S16527L-DC
Machine Features 外形参数				
Size 尺寸 (L×W×H)	2250×1500×2310mm		2700×1650×2730mm	
Column Height 立柱高度	2200mm		2700mm	
	Option 可选: 2700mm/3200mm		Option 可选: 3200mm	
Turntable Diameter 转盘直径	1500mm		1650mm	
			Option 可选: 1500mm/1800mm/2000mm/2200mm	
Weight 重量	450-500 kg			
Operator Panel 操作面板	LCD Touch Screen 触摸屏			
Electricity Features 电气参数				
Power Supply 额定电源	1P 220V-230V/110V 50/60HZ			
Installed Power 额定功率	1.25 KW			
Wrapping Features 缠绕参数				
Wrapping Speed 缠绕速度	90s / Pcs		100s / Pcs	
Turntable Speed 转盘速度	0-10 rpm			
Carriage Lifting Speed 膜架速度	0-5.4 m/min			
Load Height 货物高度	2000mm or Pillar Height minus 400mm 2000mm或立柱高度减400mm			
Load Weight 货物负载	2000kg (max.)			
Wrapping Model 缠绕方式	6 Wrapping Models 6种缠绕方式			
Film Pre-stretch 预拉伸	Damping Carriage 阻尼膜架: 120%/ 150%			
	Pre-stretch Carriage 预拉伸膜架: 100%-150%-200%-250% / 100%-400% Adjustable 可调			
Film Tensing 包装遏制力	Adjustable 可调节			
Height Control 高度调节	Photoelectric automatic 光电自动测高			
Film Carriage 膜架参数				
Carriage Types 膜架类型	Damping Carriage 阻尼膜架			
	Pre-stretch Carriage 预拉伸膜架			
Filming Method 上膜方式	By Manual 手动上膜			
Roll Features 卷膜参数				
Roll Size 尺寸 (H×Ø)	500mm×250mm		500 mm / 750mm×250mm	
Roll Diameter 卷芯直径	50/76 mm			
Roll Weight 重量	20 kg			

M Turntable Wrapper

M 型转盘缠绕机

6 Wrapping Models 6种缠绕方式

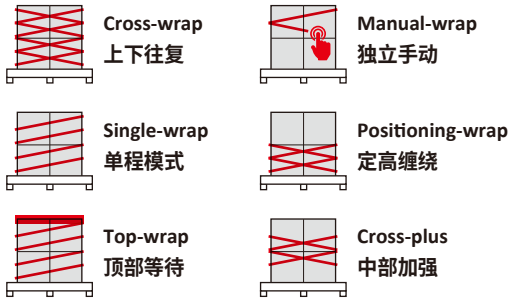

6 Optional & Accessories 6种可选配件和功能

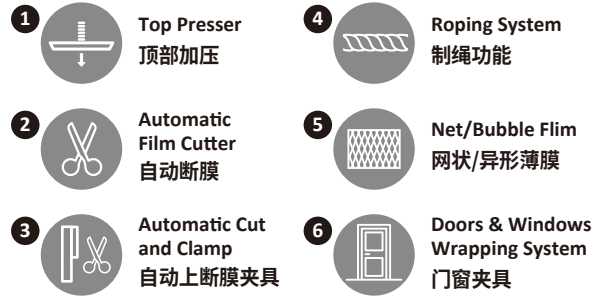

与顶部加压配合使用, 最大承重1000kg
Use with Top Presser, max. loading weight is 1000kg

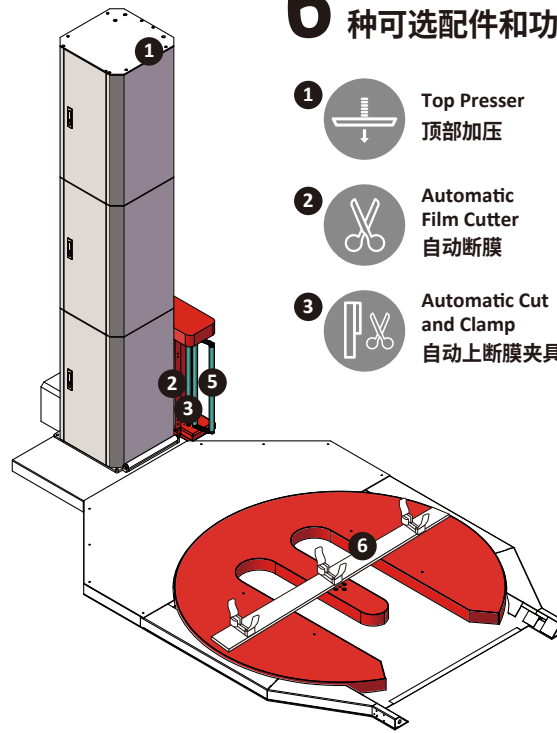

Technical Data 技术参数

	M Turntable Wrapper M型转盘缠绕机 (小立柱)	Model 型号 EF-CRT-M16522-PC	M Turntable Wrapper M型转盘缠绕机 (大立柱)	Model 型号 EF-CRT-M16527L-PC
Machine Features 外形参数				
Size 尺寸 (L×W×H)	2250×1650×2310mm		2700×1650×2730mm	
Column Height 立柱高度	2200mm		2700mm	
	Option 可选: 2700mm/3200mm		Option 可选: 2200mm/3200mm	
Turntable Diameter 转盘直径	1650mm			
Weight 重量	600-700 kg			
Operator Panel 操作面板	LCD Touch Screen 触摸屏			
Electricity Features 电气参数				
Power Supply 额定电源	1P 220V-230V/110V 50/60HZ			
Installed Power 额定功率	1.25 KW			
Wrapping Features 缠绕参数				
Wrapping Speed 缠绕速度	90s / Pcs		100s / Pcs	
Turntable Speed 转盘速度	0-10 rpm			
Carriage Lifting Speed 膜架速度	0-5.4 m/min			
Load Height 货物高度	2000mm or Pillar Height minus 400mm		2000mm或立柱高度减400mm	
Load Weight 货物负载	1500kg			
Wrapping Model 缠绕方式	6 Wrapping Models 6种缠绕方式			
Film Pre-stretch 预拉伸	Damping Carriage 阻尼膜架: 120%/ 150%			
	Pre-stretch Carriage 预拉伸膜架: 100%-150%-200%-250% / 100%-400% Adjustable 可调			
Film Tensing 包装遏制力	Adjustable 可调节			
Height Control 高度调节	Photoelectric automatic 光电自动测高			
Film Carriage 膜架参数				
Carriage Types 膜架类型	Damping Carriage 阻尼膜架			
	Pre-stretch Carriage 预拉伸膜架			
Filming Method 上膜方式	By Manual 手动上膜			
Roll Features 卷膜参数				
Roll Size 尺寸 (H×Ø)	500mm×250mm		500 mm / 750mm×250mm	
Roll Diameter 卷芯直径	50/76 mm			
Roll Weight 重量	20 kg			

Low Turntable Wrapper 超薄转盘缠绕机

6 Wrapping Models 6种缠绕方式



Cross-wrap
上下往复



Manual-wrap
独立手动



Single-wrap
单程模式



Positioning-wrap
定高缠绕



Top-wrap
顶部等待



Cross-plus
中部加强

6 Optional & Accessories 6种可选配件和功能



1 Loading Ramp
装载斜坡



3 Automatic Film Cutter
自动断膜

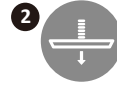

2 Top Presser
顶部加压



4 Automatic Cut and Clamp
自动上断膜夹具



5 Roping System
制绳功能



6 Net/Bubble Film
网状/异形薄膜

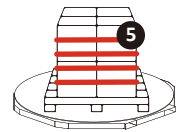
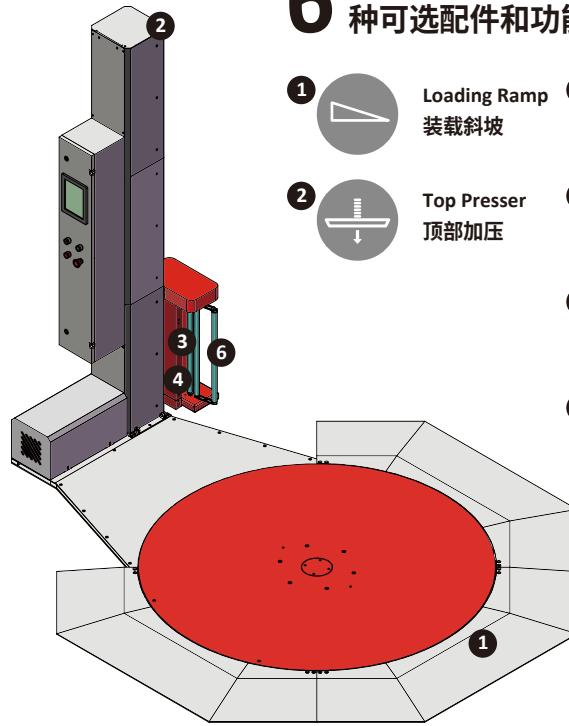

Technical Data 技术参数

	Low Turntable Wrapper 超薄转盘缠绕机(小立柱)	Model 型号 EF-CRT-L16822-PC	Low Turntable Wrapper 超薄转盘缠绕机(大立柱)	Model 型号 EF-CRT-L16827L-PC
Machine Features 外形参数				
Size 尺寸 (L×W×H)	2500×1680×2230mm		2700×1680×2730mm	
Column Height 立柱高度	2200mm		2700mm	
	Option 可选: 2700mm/3200mm		Option 可选: 2200mm/3200mm	
Turntable Diameter 转盘直径	1680mm			
Weight 重量	500-600 kg			
Operator Panel 操作面板	LCD Touch Screen 触摸屏			
Electricity Features 电气参数				
Power Supply 额定电源	1P 220V-230V/110V 50/60HZ			
Installed Power 额定功率	1.25 KW			
Wrapping Features 缠绕参数				
Wrapping Speed 缠绕速度	90s / Pcs		100s / Pcs	
Turntable Speed 转盘速度	0-10 rpm			
Carriage Lifting Speed 膜架速度	0-5.4 m/min			
Load Height 货物高度	2000mm or Pillar Height minus 400mm 2000mm或立柱高度减400mm			
Load Weight 货物负载	1000kg			
Wrapping Model 缠绕方式	6 Wrapping Models 6种缠绕方式			
Film Pre-stretch 预拉伸	Damping Carriage 阻尼膜架: 120%/ 150%			
	Pre-stretch Carriage 预拉伸膜架: 100%-150%-200%-250% / 100%-400% Adjustable 可调			
Film Tensing 包装遏制力	Adjustable 可调节			
Height Control 高度调节	Photoelectric automatic 光电自动测高			
Film Carriage 膜架参数				
Carriage Types 膜架类型	Damping Carriage 阻尼膜架			
	Pre-stretch Carriage 预拉伸膜架			
Filming Method 上膜方式	By Manual 手动上膜			
Roll Features 卷膜参数				
Roll Size 尺寸 (H×Ø)	500mm×250mm		500 mm / 750mm×250mm	
Roll Diameter 卷芯直径	50/76 mm			
Roll Weight 重量	20 kg			



Packaging Machinery made for you



易尔富来普智能设备(嘉兴)有限公司

Earflap Intelligent Equipment (Jiaxing) Co., Ltd

地址：浙江省嘉兴市南湖区建瑞大厦A座1105室
Add : Room 1105, Jianrui Building A , Nanhu Dist.
Jiaxing City, Zhejiang Province

电话 / Tel: 0573-82822099
邮箱 / Email: service@earflappack.com
网址 / Web: www.earflappack.com

