

Universal[®]

STEAM BOILER

TYPE: SB



Universal[®]

Örnek Mahallesi Ercüment Batınay Sokak No: 14 Duman Kaya
Icon Residence A3 Blok Kat: 32-33 Daire:170
Ataşehir / İSTANBUL
Tel: (0212) 549 70 70
Fax: (0212) 671 40 06

www.universalkazan.com
info@universalkazan.com

Oil and Natural Gas Gas fired scotch Type



OIL AND NATURAL GAS FIRED SCOTCH TYPE 3 PASS, FIRE SMOKE TUBE STEAM BOILER. TYPE:SB

DESIGN: High pressure, 3 Pass, fire-smoke tube Scotch type steam boilers are manufactured according to Lloyd rules, TRD, DIN and EN norms(TSE, TRD, DIN, EN, GOST and ASME norms)

MATERIALS: Cylinder shell, flue plates and combustion chamber are manufactured from HI-HI(boiler sheet)(boiler steel plate). Smoke tubes are seamless boiler tubes (according to DIN 17155).

HIGH EFFICIENCY: Flue gases, formed as a result of good combustion, pass through convection surfaces and leave the boiler without causing low temperature corrosion. Maximum heat transfer and high efficiency (88-90%) is obtained.

- Responds sudden demands of great (huge) amount of steam
- Has a large evaporation surface and large steam storage volume
- Has a large and corrugated combustion chamber
- Hydrolic test applied at 1,5 times higher than the operating pressure
- The combustion chamber is easily reachable from the explosion gate, the smoke tubes are easily reachable from the front door and the water-side is easily reachable from the manhole and the handholes

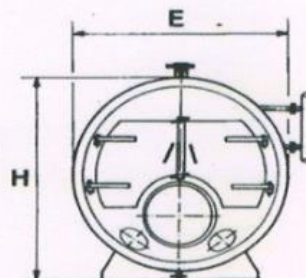
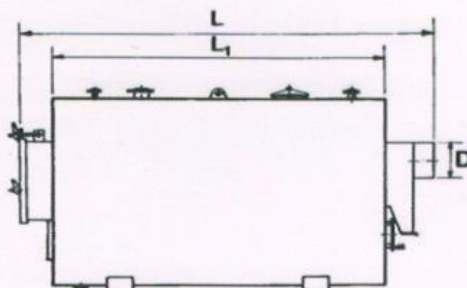
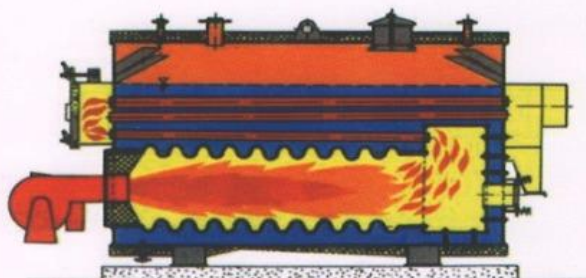

TYPE: SB- Capacity and Main Dimension

TYPE		SB 5	SB 10	SB 15	SB 20	SB 25	SB 30	SB 35	SB 40	SB 50	SB 60	SB 70	SB 80	SB 90	SB 100	SB 125	SB 150	SB 200	SB 250	SB 300	SB 350	SB 400
Steam capacity	kg/h	150	300	500	750	900	1100	1350	1550	1900	2400	2800	3200	3800	4200	5200	6250	8350	10500	12500	14600	16700
Length	mm	1950	2100	2330	2490	2625	2745	2860	3010	3200	3375	3530	3680	3820	4150	4525	4820	5340	5800	6315	6700	7055
Width	mm	1350	1690	1820	1850	1900	2000	2000	2000	2250	2350	2410	2500	2550	2650	2650	2830	3000	3200	3350	3500	3550
Height	mm	1500	1840	1970	2000	2050	2150	2150	2150	2400	2500	2560	2750	2800	2900	2900	3080	3250	3450	3600	3750	3800
Steam volume	m ³	0,21	0,44	0,65	0,71	0,92	1,17	1,23	1,32	1,55	1,70	1,83	1,97	2,09	2,36	2,99	4,25	4,97	5,69	7,16	7,85	8,39
Water volume	lt	430	1030	1360	1420	1520	1550	1580	1650	2755	3850	4450	5070	5740	5900	6180	7495	9390	11570	13740	16865	18600
Stack Diameter	mm	200	250	300	300	350	350	350	400	450	500	550	600	600	600	650	700	700	800	1000	1000	1000
Flue Gas Pressure Drop	mm SS	15	15	30	30	30	30	30	30	30	30	40	50	50	60	70	70	80	90	100	100	100
Approximate weight	6 barg kg/h	1100	1750	2250	2600	2900	3300	3700	4000	5000	5450	6100	7100	7800	9400	10700	13200	16700	20900	23500	27250	31000
	10 barg kg/h	1300	2000	2450	2900	3200	3900	4300	4600	5800	6100	6900	7950	8650	11100	11850	14700	18750	23900	27900	31000	34700

* Capacities refer to the operating pressure of 6 barg and the feed water temperature of 70°C
* Dimensions may be changed without notice

Universal[®]

PRESSURIZED COMBUSTION STEAM BOILERS

TYPE:RB

Light oil/ Heavy oil/ Natural gas/ Lpg burned

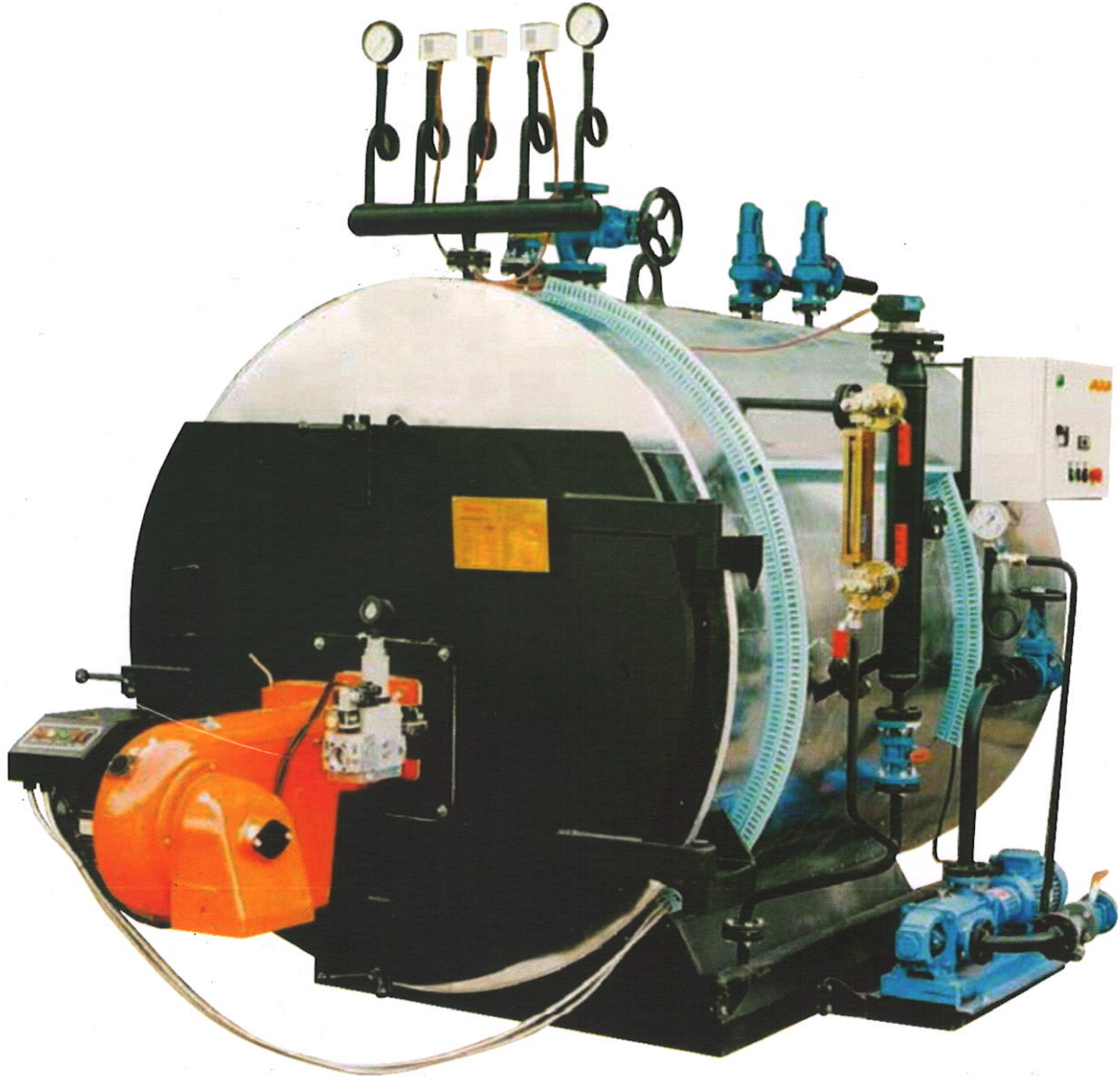

Universal[®]

İkitelli Organiza Sanayi Bölgesi Metal - İş Sanayi Sitesi
8. Ada No: 36 Başakşehir / İSTANBUL
Tel: 0212 549 70 70 • Fax: 0212 671 40 06
E-mail: info@universalkazan.com
www.universalkazan.com

PRESSURIZED COMBUSTION STEAM BOILERS TYPE:RB

Light oil/ Heavy oil/ Natural gas/ Lpg burned

Pressurized combustion (Radiation) type cylindrical, flame smoke tube steam boilers have 3 passes where first and second passes occur as reverse flame in the large combustion chamber. This constitutes turbulence occurring more efficient air-fuel mixture and good combustion. On the third pass, hot gas passes through the smoke tubes. Temperature of the gas is lowered as much as possible during the flow in the tubes until the flue gas leaves the boiler. Thus high boiler efficiency of 85-90% is obtained.

ADVANTAGES

- Has large and corrugated combustion chamber
- Has relatively small dimensions and requires small installation area
- Produces steam rapidly
- Has optimum heat transfer surface (it does not have excessive heat load per unit heat transfer surface)
- Has minimum heat loss on exterior surface
- Has long life time and high efficiency
- The combustion chamber and the smoke tubes are easily reachable from the front door and the waterside is easily reachable from the manhole and the handholes)

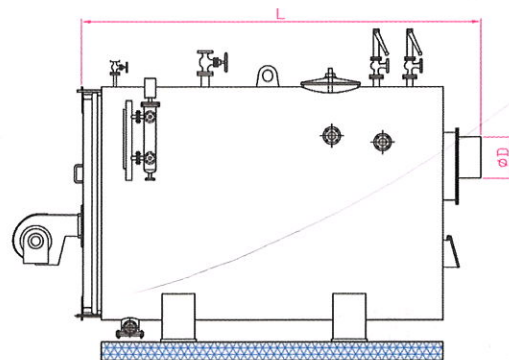
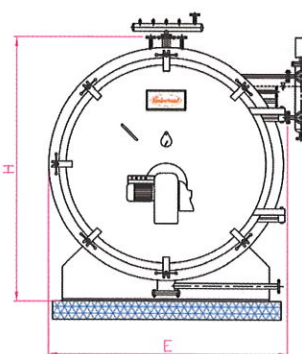
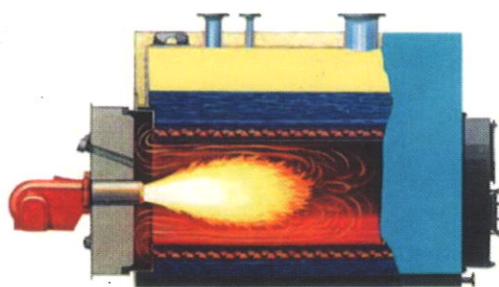
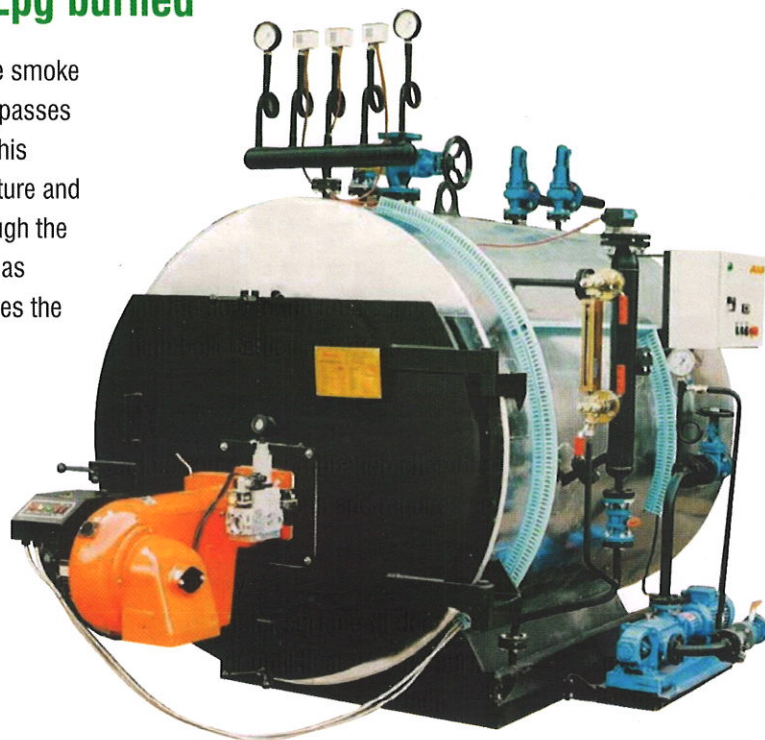

TIP		RB 250	RB 300	RB 350	RB 400	RB 450	RB 500	RB 600	RB 750	RB 1000	RB 1250	RB 1500	RB 1750	RB 2000	RB 2500	RB 3000	RB 3500	RB 4000	RB 5000	RB 6000
Steam capacity	kg/h	250	300	350	400	450	500	600	750	1000	1250	1500	1750	2000	2500	3000	3500	4000	5000	6000
Length	mm	1580	1680	1780	1880	1880	2100	2200	2300	2500	2700	2950	3100	3200	3400	3700	3850	4100	4400	4700
Width	mm	1100	1200	1250	1250	1250	1400	1450	1600	1600	1700	1750	1750	1750	1800	2000	2150	2250	2350	2550
Height	mm	1250	1350	1400	1400	1400	1550	1600	1750	1750	1850	1900	1900	1950	2150	2150	2300	2400	2500	2700
Steam volume	m ³	0,21	0,25	0,28	0,30	0,37	0,46	0,51	0,68	0,76	0,89	1,18	1,29	1,61	1,73	1,96	2,81	3,18	3,95	4,50
Water volume	lt	410	540	680	715	630	990	1180	1280	1390	2200	2240	2590	2860	2930	3920	4730	7350	7500	11050
Stack diameter	mm	200	200	250	250	250	300	350	400	400	400	400	450	500	500	550	600	600	650	700
Flue gas pressure Drop	mm SS	10	10	10	15	15	15	18	20	25	30	40	50	50	55	60	70	80	90	100
Approximate weight	6 barg kg/h	600	740	840	900	920	1230	1415	1765	1930	2400	2700	2970	3565	4050	4990	5880	7050	8540	10850
	10 barg kg/h	700	850	950	1050	1100	1400	1600	2030	2200	2750	3100	3400	4100	4650	5600	6700	8000	9750	12000
Combustion chamber	L mm	900	1000	1100	1200	1200	1400	1500	1600	1800	2000	2250	2400	2500	2700	3000	3150	3400	3700	4000
	D mm	500	600	600	600	600	700	800	900	900	1000	1000	1000	1150	1150	1150	1250	1250	1380	1450

* Dimensions may be changed without notice

Universal[®]

THERMANL OIL BOILERS

TYPE:KYK

Temperature in the system is up to 300°C at atmospheric pressure

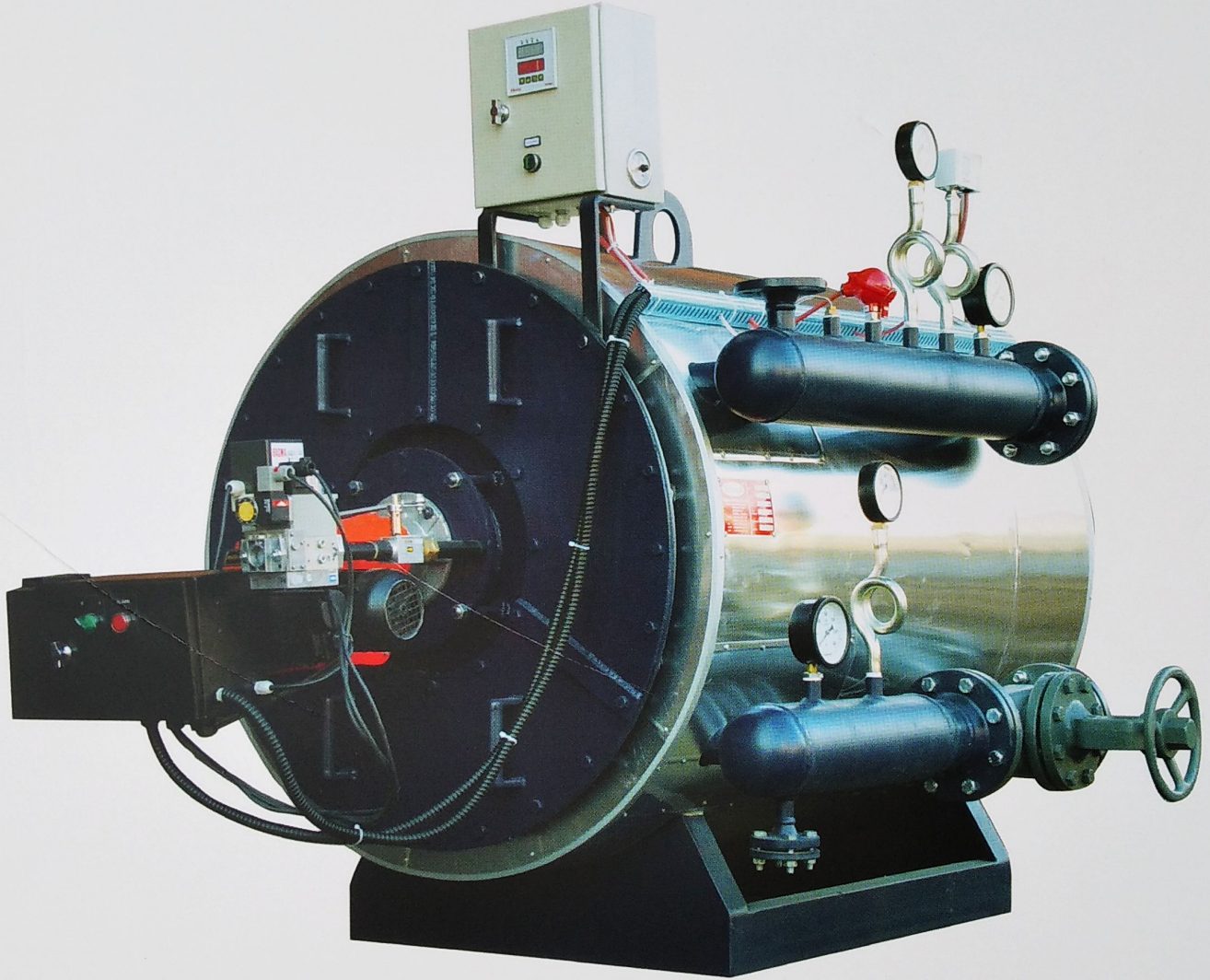

Universal[®]

İkitelli Organiza Sanayi Bölgesi Metal - İş Sanayi Sitesi
8. Ada No: 36 Başakşehir / İSTANBUL
Tel: 0212 549 70 70 • Fax: 0212 671 40 06
E-mail: info@universalkazan.com
www.universalkazan.com

THERMANL OIL BOILERS TYPE:KYK

Temperature in the system is up to 300°C at atmospheric pressure

ADVANTAGES

- Temperature in the system is up to 300°C at atmospheric pressure. Heat carrying oil does not cause sedimentation, corrosion or crust
- Thermal oil does not need conditioning
- There is no risk of freezing in cold weather
- The outlet temperature can be adjustable up to 300°C
- Thermal oil can be used either to reach high temperatures or to produce steam, hot water or superheated water



TYPE:KYK - Capacity and Main Dimensions

TYPE		KYK 100	KYK 125	KYK 150	KYK 200	KYK 250	KYK 300	KYK 400	KYK 500	KYK 600	KYK 800	KYK 1000	KYK 1250	KYK 1500	KYK 2000	KYK 2500	KYK 3000	KYK 3500	KYK 4000	KYK 5000	KYK 6000	KYK 8000	KYK 10000
Heating Capacity	kcal/h. 10 ³	100	125	150	200	250	300	400	500	600	800	1000	1250	1500	2000	2500	3000	3500	4000	5000	6000	8000	10000
	kW	115	156	174	233	291	349	465	581	698	930	1163	1453	1744	2326	2907	3488	4070	4651	5814	6977	9302	11628
Oil outlet temperature	°C	280	280	280	280	280	280	280	280	280	280	280	280	280	280	280	280	280	280	280	280	280	280
Oil inlet temperature	°C	240	240	240	240	240	240	240	240	240	240	240	240	240	240	240	240	240	240	240	240	240	240
Length without burner	mm	1250	1350	1450	1550	1650	1880	2630	2800	2300	2500	2700	2825	3325	3825	4025	4425	4550	5050	5450	5850	5850	5850
Width without fittings	mm	1150	1200	1200	1330	1300	1330	1430	1525	1750	1900	2000	2000	2250	2600	2700	2850	3000	4075	3425	3715	4180	5350
Hight without fittings	mm	1000	1050	1050	1150	1150	1150	1250	1400	1500	1660	1760	1960	2000	2350	2450	2600	2750	2800	3150	3400	3800	4000
Oil inlet diameter	DN	32	32	32	40	40	50	65	65	65	80	100	100	125	125	150	150	150	200	200	200	250	250
Oil outlet diameter	DN	32	32	32	40	40	50	65	65	65	80	100	100	125	125	150	150	150	200	200	200	250	250
Oil contents	lt	20	31	36	50	56	68	91	133	160	252	674	1043	1292	2175	2561	3636	4158	4719	7122	8604	13977	17498
Stack diameter	mm	150	150	150	200	200	200	250	250	300	300	350	400	450	500	550	600	650	700	800	900	1000	1150
Resistance of oil side	mbar	450	460	500	525	550	600	800	850	850	870	950	1000	1100	1200	1400	2200	2500	2750	3000	3000	3000	3500
Resistance of flue gas side	mbar	1.0	1.0	1,2	1,5	1,5	1,6	1,8	2,0	2,5	3,0	4,0	5,0	5,0	5,5	6,0	7,0	8,0	9,0	10,0	11,5	12,0	15,0
Weight (App.)	kg/h	920	1025	1100	1360	1440	1875	2065	2645	3100	3250	4500	6150	7200	10450	11630	14955	17150	19100	24685	31625	42275	54230

* Dimensions may be changed without notice

Universal[®]

COMPACT STEAM GENERATORS

TYPE:KBJ

■ Light Oil / Heavy Oil / Natural Gas / LPG Burned ■



Universal[®]

İkitelli Organiza Sanayi Bölgesi Metal - İş Sanayi Sitesi
8. Ada No: 36 Başakşehir / İSTANBUL
Tel: 0212 549 70 70 • Fax: 0212 671 40 06
E-mail: info@universalkazan.com
www.universalkazan.com

COMPACT STEAM GENERATORS

TYPE:KBJ

Light oil/ Heavy oil/ Natural gas/ Lpg burned

- Universal Compact Steam Generators are used in hotels, laundries, garment workshops, textile factories, food and beverage industry, concrete curing, dry cleaning workshops, bottling facilities, ironing shops, washing and cleaning processes, hosieries and all other processes of industries which need steam
- Requires small installation area and produces steam rapidly
- Produced for hard conditions of operation and yet not easily affected by hard and untreated water
- Operates full automatically and safely
- Has several features for security
- Developed in long term experiences and proved its quality with hundreds of examples working for many years in Turkey and all over the world
- It is a very compact device with burner, feed-water pump, condensate tank, water filter, automatic water treatment unit, electric panel and its installation



www.universalkazan.com

TYPE KBJ - Capacity and Main Dimensions

TYPE	KBJ 500	KBJ 600	KBJ 750	KBJ 1000	KBJ 1250	KBJ 1500	KBJ 1750	KBJ 2000
Steam capacity	500	600	750	1000	1250	1500	1750	2000
Length without burner	2600	2600	2600	2950	2950	3200	3500	3500
Total width (mm)	1150	1650	1750	1750	1880	1880	1880	2140
Height without fittings (mm)	2270	2370	2470	2470	2650	2650	2650	2910
Total length (mm)	3400	3400	3510	3860	3860	4200	4500	4500
Total height (mm)	2520	2620	2720	2720	2900	2900	2900	3160
Water volume (lt)	772	841	953	1101	1344	1482	1626	2400
Stack diameter (mm)	300	350	400	400	400	400	450	500
Approximate weight (kg)	2625	2900	3215	3640	4200	4500	4900	6400

* Dimensions may be changed without notice

Universal[®]

PACKAGE MINI STEAM GENERATORS

TYPE:MBÜ

■ Light Oil / Heavy Oil / Natural Gas / LPG Burned ■



Universal[®]

İkitelli Organiza Sanayi Bölgesi Metal - İş Sanayi Sitesi
8. Ada No: 36 Başakşehir / İSTANBUL
Tel: 0212 549 70 70 • Fax: 0212 671 40 06
E-mail: info@universalkazan.com
www.universalkazan.com

PACKAGE MINI STEAM GENERATORS TYPE:MBÜ

Light oil/ Heavy oil/ Natural gas/ Lpg burned

- Universal Compact Steam Generators are used in hotels, laundries, garment workshops, bottling factories, ironing shops, washing and cleaning processes, hosieries and all other processes of industries that need small amount of steam
- Requires small installation area and produces steam in a very short time
- Produced for hard conditions of operation and not easily affected by hard and untreated water
- Operates full automatically and safely
- Has several features for security
- Easy to operate without supervision
- Developed in long term experiences and proved its quality with hundreds of examples working for many years in Turkey and all over the world
- It is a very compact device with the burner, feed-water pump, condensate tank, water filter, automatic water treatment unit, electric panel and its installation

MBU type steam generators contain:

- Steam generator
- Boiler fittings
- Boiler automatics
- Safety systems
- Feed-water pump and its fittings
- Burner
- Electric switchbox

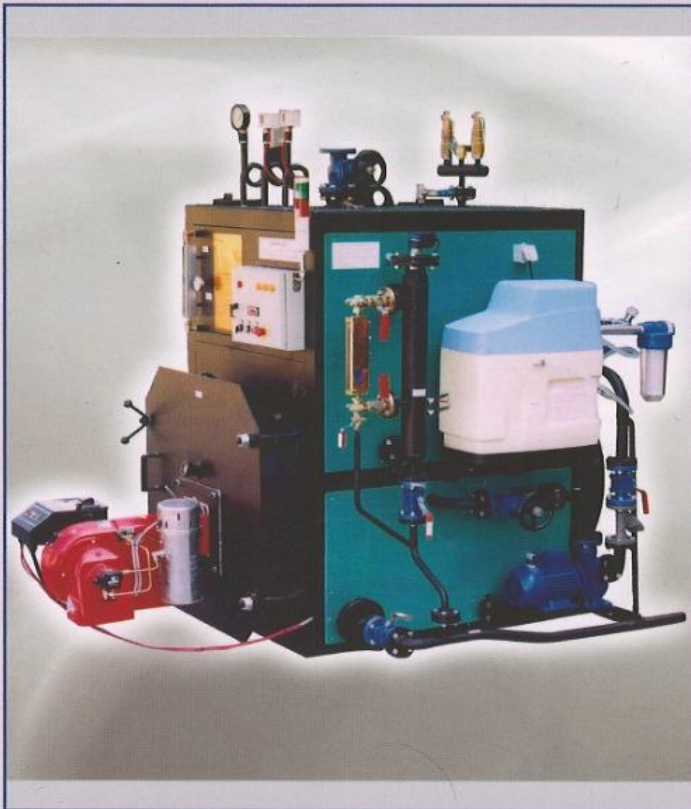

Capacity and Main Dimensions

	MBÜ 200	MBÜ 300	MBÜ 400	MBÜ 500
Steam Capacity (kg/h)	200	300	400	500
Length Without Burner (mm)	1600	1800	1900	2040
Width Without Armatures (mm)	1040	1200	1200	1250
Height Width Without Armatures (mm)	1635	1920	1920	1970
Total Length (mm)	2400	2600	2700	2840
Total Width (mm)	1380	1530	1530	1580
Total Height (mm)	1885	2170	2170	2220
Water Volume (lt)	240	430	470	620
Flue Outlet (mm)	200	250	300	300
App. Weight (kg)	1100	1500	1650	1800

* Dimensions may be changed without notice

HOT WATER BOILER

In hot water boilers, the most ideal type of boiler is the 3-pass, fire-tube, Scotch type, cylindrical boiler. These boilers achieve high efficiency, long life, and low emission values.

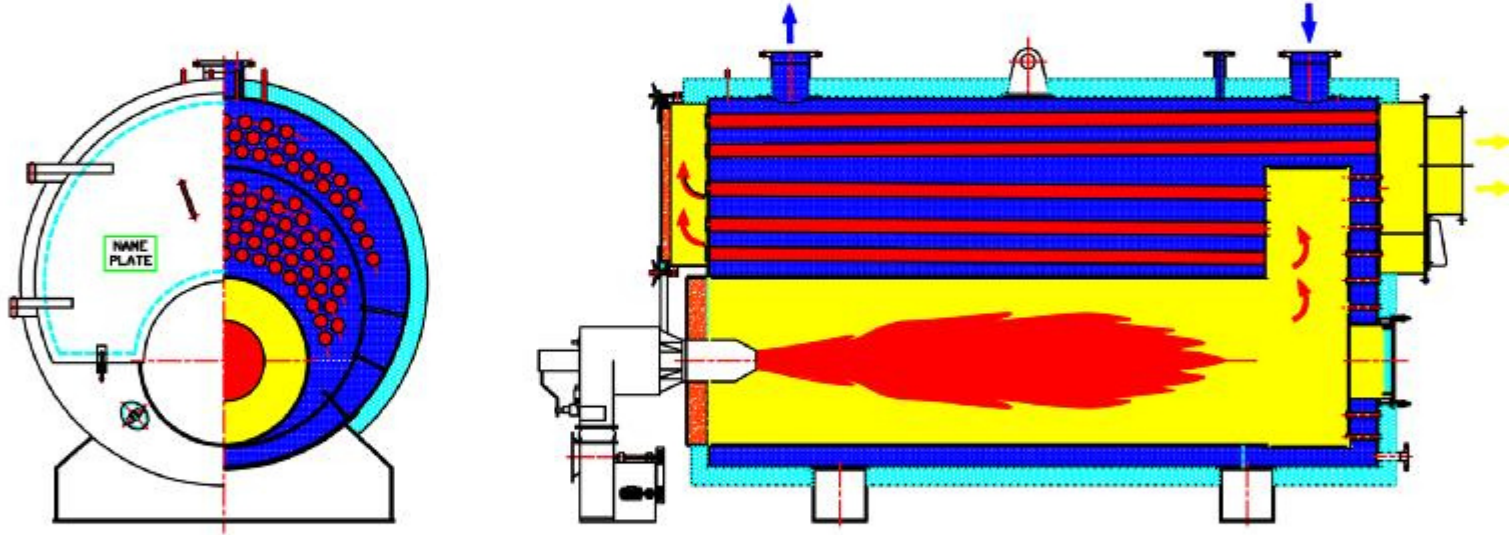

Figure 1: SSK Type Scotch Boiler, real 3-pass, hot water boiler, boiler efficiency 92%



SSK Type Scotch Boiler, 3-pass, hot water boiler

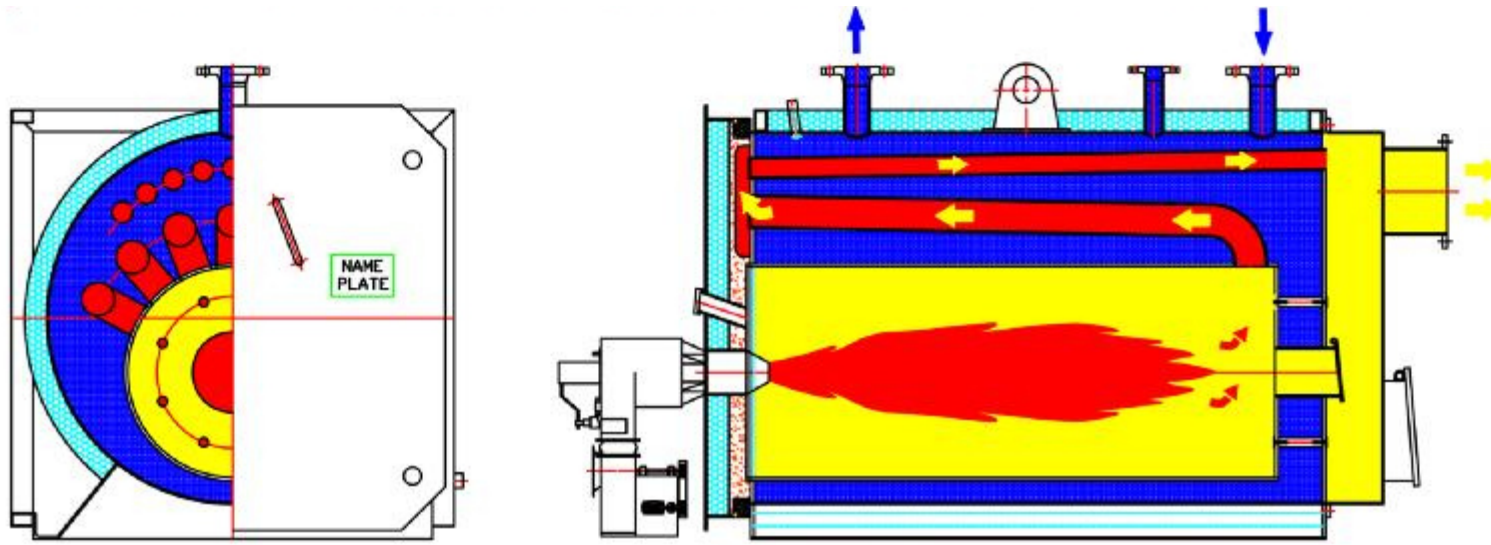

Figure 2: ÜGK Type real 3-pass, hot water boiler, boiler efficiency 92%

In counter-pressure, radiation type, 2-pass hot water boilers, the burner flame is formed in the combustion chamber in reverse turning flame shape, and at high temperatures, it enters the smoke tubes. Through the use of turbulators placed in the tubes, heat transfer is increased, and the temperature of the flue gas entering the chimney is reduced to normal values. However, contrary to the temperature, due to the flame, the NOx value increases significantly (Figure 3). To prevent this, the flue gases are brought to the front of the boiler through one or two tubes at the end of the combustion chamber.

From here, the flue gases pass through the smoke tubes and go to the chimney. To increase heat transfer here as well, especially in natural gas combustion, turbulators should be placed in the smoke tubes. This is not a true three-pass boiler. The main goal is to reduce the amount of NOx in the 2-pass boiler due to the flame's reverse movement (Figure 4).

Note: The exteriors of all boilers are covered with stainless steel sheets over rock wool.

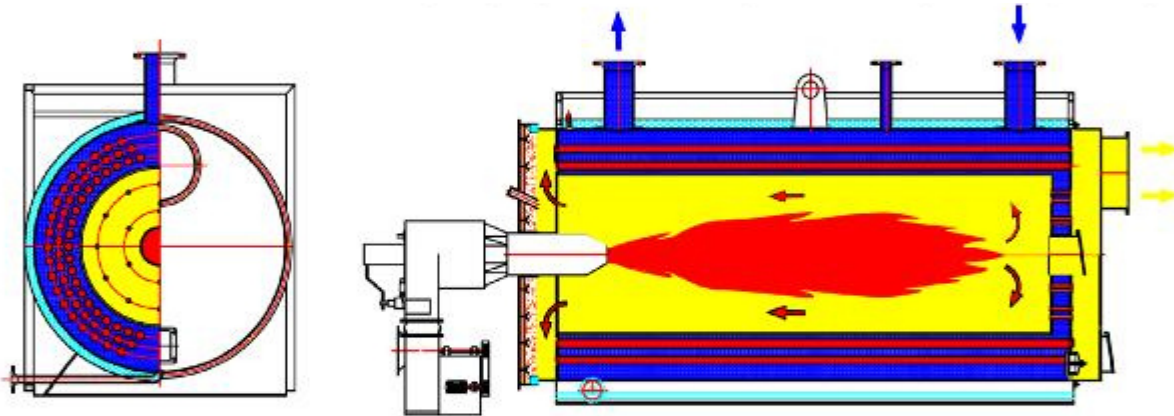

Figure 3: RKK Type 2-pass, counter-pressure hot water boiler, boiler efficiency 90%

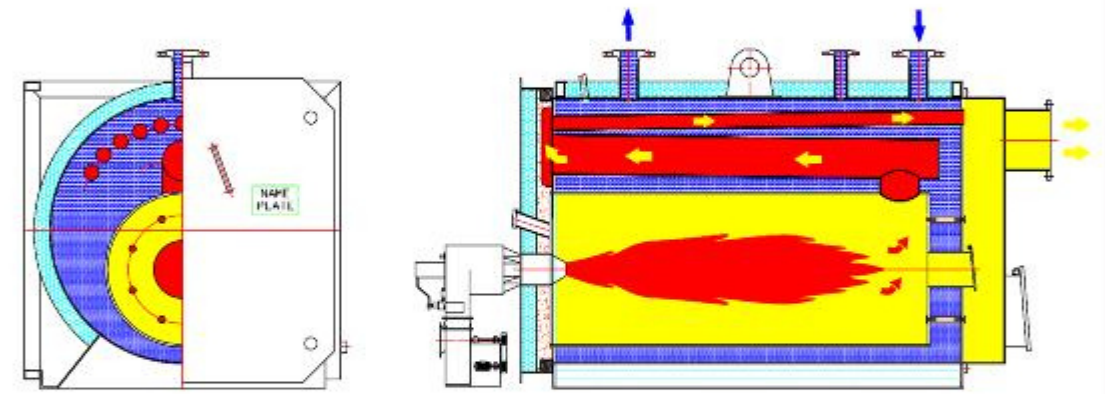

Figure 4: A 3-pass boiler created to reduce the NOx value in the 2-pass boiler, boiler efficiency 90% to 92%

* We reserve the right to change the dimensions due to technical developments.

Note: Please contact our company for boiler dimensions.

ÜNİVERSAL KAZAN PAZARLAMA VE TAAHÜT LTD. ŞTİ

Fabrika : İkitelli OSB, Metal İş Sanayi Sitesi Yolu 8.Blok No:36-38, 34490
İkitelli Osb/Başakşehir/İstanbul



Telefon: (0212) 549 70 70
info@universalkazan.com.tr www.universalkazan.com.tr



ÜNİVERSAL KAZAN PAZARLAMA VE
TAAHÜT LTD. ŞTİ.



SCOTCH TYPE, 3 PASS, FIRE-SMOKE TUBE HOT WATER BOILER

Tip : SSK

OIL AND NATURAL GAS FIRED

DESIGN :

High pressure, 3 pass, fire-smoke tube Scotch type overheated/hot water boilers are manufactured according to EN 12953

Lloyd rules, TRD, DIN and EN norms.

MATERIALS:

Cylinder shell, flue plates and combustion chamber are manufactured from P265 GH (boiler sheet)

Smoke tubes are seamless boiler tubes (according to EN 10028-2)

HIGH EFFICIENCY:

Flue gases, formed as a result of good combustion, pass through convection surfaces and leave the boiler without causing low temperature corrosion. maximum heat transfer and high efficiency (88-90%) is obtained.

Schematic Diagram

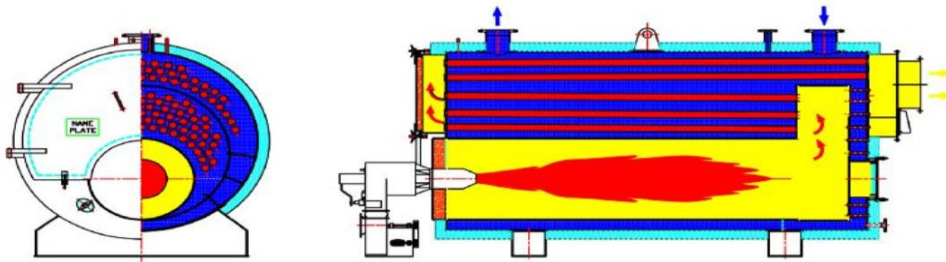

Type :SSK - Capacity and Dimension

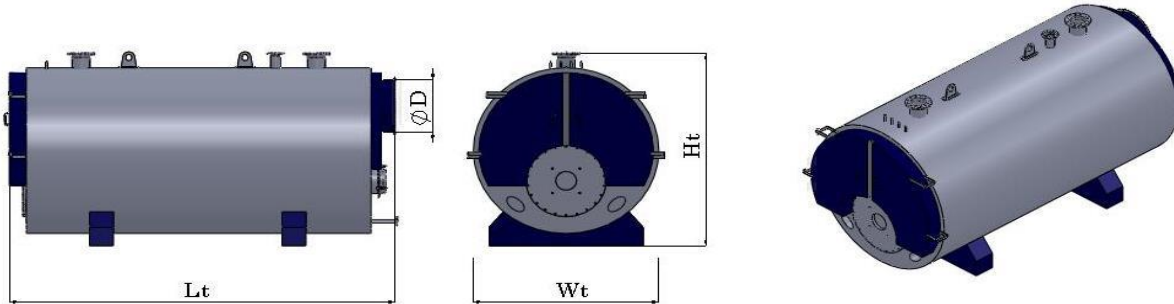

Surface Area	Heat Capacity	Length	Width	Height	Stack diameter	Water Volume	Flue gas pressure Drop	Bare Weight	Weight
Surface Area	Q	Lt	Wt	Ht	Ø D	Vs	DP	M	M _i
m ²	kcal/h	mm	mm	mm	mm	lt	mmSS	kg	kg
5	120.000	2.100	1.200	1.450	200	660	25	920	1.580
10	240.000	2.550	1.350	1.600	250	1.070	30	1.450	2.520
15	360.000	2.700	1.450	1.700	250	1.420	30	1.730	3.150
20	500.000	2.900	1.550	1.800	300	1.900	40	2.090	3.990
25	600.000	2.900	1.700	1.950	300	2.270	40	2.490	4.760
30	720.000	2.950	1.800	2.050	300	2.740	50	2.770	5.510
35	840.000	3.075	1.800	2.050	350	2.820	50	2.980	5.800
40	960.000	3.275	1.950	2.200	350	3.700	50	3.490	7.190
50	1.200.000	3.715	1.950	2.200	400	4.150	50	3.810	7.960
60	1.440.000	3.775	2.100	2.350	400	4.850	60	5.020	9.870
70	1.680.000	4.175	2.100	2.350	450	5.490	60	5.520	11.010
80	1.920.000	4.200	2.200	2.450	500	6.070	60	6.030	12.100
90	2.160.000	4.400	2.200	2.450	500	6.310	60	6.530	12.840
100	2.400.000	4.500	2.300	2.550	550	7.470	60	7.090	14.560
125	3.000.000	4.800	2.400	2.650	600	8.490	70	8.750	17.240
150	3.600.000	5.150	2.600	2.850	650	11.550	70	10.520	22.070
175	4.200.000	5.350	2.600	2.850	700	11.770	70	11.180	22.950
200	4.800.000	5.550	2.750	3.050	750	13.680	70	13.680	27.360
250	6.000.000	6.200	2.950	3.250	850	18.360	80	16.300	34.660
300	7.200.000	6.700	3.100	3.400	900	21.830	80	19.210	41.040
350	8.400.000	5.600	3.850	4.150	950	29.410	90	25.320	54.730
400	9.600.000	5.800	3.850	4.150	1.000	30.080	100	26.950	57.030

Universal[®]

HOT WATER BOILER

TYPE:ÜRK

Light oil/ Heavy oil/ Natural gas/ Lpg burned



Universal[®]

İkitelli Organiza Sanayi Bölgesi Metal - İş Sanayi Sitesi
8. Ada No: 36 Başakşehir / İSTANBUL
Tel: 0212 549 70 70 • Fax: 0212 671 40 06
E-mail: info@universalkazan.com
www.universalkazan.com

HOT WATER BOILER TYPE:ÜRK

Light oil/ Heavy oil/ Natural gas/ Lpg burned

- Suitable for heating buildings, hotels, hospitals, plants and factories
- Has small dimensions and requires small installation area
- Provides stable operating conditions in a very short time after the start-up
- Has high efficiency
- Environmentally friendly
- Has pressurized combustion chamber and 3 pass design
- If requested automatic control unit and elements can be installed

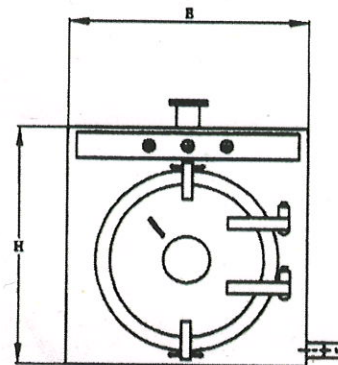
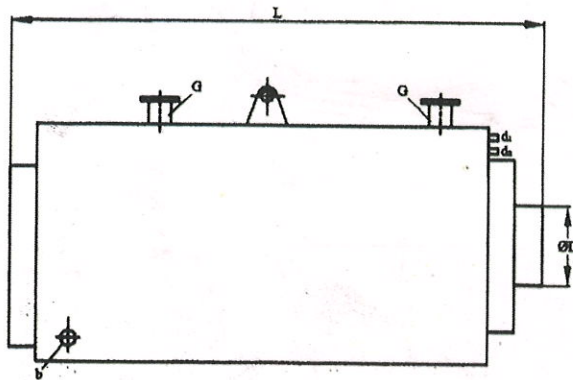

TYPE		40	50	60	80	100	125	150	175	200	250	300	350	400	450	500	600	700	800	900	1000	1250	1500	1750	2000	2500	3000
Capacity	(kcal/h)	40000	50000	60000	80000	100000	125000	150000	175000	200000	250000	300000	350000	400000	450000	500000	600000	700000	800000	900000	1000000	1250000	1500000	1750000	2000000	2500000	3000000
Total length	L (mm)	1250	1350	1450	1550	1550	1550	1750	1850	1850	2150	2150	2250	2500	2560	2660	2760	3000	3000	3250	3250	3550	3750	3950	4150	4550	4950
Height	H (mm)	1150	1150	1150	1150	1250	1250	1250	1250	1360	1360	1450	1450	1550	1550	1550	1550	1550	1650	1650	1750	1880	1880	1980	2125	2230	2380
Width	E (mm)	800	800	800	800	900	900	900	900	1010	1010	1100	1100	1200	1200	1200	1200	1200	1300	1300	1400	1530	1530	1630	1770	1880	2030
Stack diameter	Ø D (mm)	200	200	200	200	200	200	200	200	200	250	300	300	350	350	350	350	350	350	350	350	450	450	500	500	550	600
Water inlet - outlet	G (DN)	40	40	40	50	50	50	65	65	65	65	65	65	80	80	80	100	100	125	125	125	150	200	200	200	250	250
Expansion connections	d1=d2(inc)	1"	1"	1"	1"	1 1/4"	1 1/4"	1 1/4"	1 1/2"	1 1/2"	1 1/2"	1 1/2"	2"	2"	2"	2"	2"	2 1/2"	2 1/2"	2 1/2"	2 1/2"	2 1/2"	2 1/2"	3"	3"	3"	3"
Drain	b (inc)	1/2"	1/2"	1/2"	1/2"	1/2"	1/2"	1/2"	1/2"	3/4"	3/4"	3/4"	1"	1"	1"	1"	1"	1"	1"	1 1/4"	1 1/4"	1 1/4"	1 1/4"	1 1/4"	1 1/2"	1 1/2"	1 1/2"
Pressure Drop	(mmSS)	3	3	4	4	5	7	10	10	10	15	15	15	18	20	25	25	28	30	40	50	50	60	60	60	60	60
Water volume	Litre	189	190	211	231	285	285	334	358	444	534	738	781	1015	1015	1030	1135	1256	1414	1548	1723	27000	2878	3336	3935	4739	4749

* Dimensions may be changed without notice



SUPER FAST SANITARY HOT WATER HEATER

TYPE:ÜSB

Utilises steam, hot water, superheated water and thermal oil for producing sanitary hot water

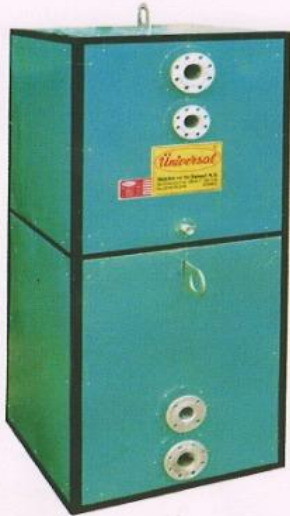

It is the right unit for apartment buildings, hotels, laundries, industrial plants and similar places.

IT IS RAPIDLY GENERATES HOT WATER IN A SMALL HEAT TRANSFER VOLUME

Smaller than conventional units and produces hot water rapidly because of large heat transfer surface.

IT INCLUDES REPLACEABLE STRAIGHT TUBES HEATING COIL

In general, the water to be heated is not treated or softened before entering to the unit. After a time period, tubes are covered with limestones and thus heat transfer efficiency decreases. In this case, the concerned tubes need to be cleaned or replaced. Our unit makes possible this opportunity and provides long term service efficiently and economically.

IT IS HYGIENIC AND RESISTANT TO CORROSION

Optionally, it is made of stainless steel or fully galvanized sheet. Thus, there is no corrosion risk. Forming of any bacteria is avoided, since the temperature is above 60°C throughout the unit. Some kind of microbes exist and increase rapidly at temperatures 30-55 °C and cause legioner disease with death effect. World Health Organisation recommends to keep water temperature at least 60°C or more. It is possible to adjust this temperature by mixing with cold water.

IT IS ECONOMIC AND EFFICIENT IN TERMS OF ENERGY CONSUMPTION

Since it has smaller volumes comparing conventional units and covered with isolation material, heat losses are very low

DIFFERENT TYPE OF HEATING FLUIDS CAN BE USED

Central heating hot water, superheated water, steam and superheated thermal oil can be used as the heating fluid.



Header fluid	Hot Water (90/70 °C)		Steam at 4 bag		DIMENSIONS			CONNECTION DIAMETERS					
	Water capacity at 60 °C lt/h	Heat Demand kcal/h	Water capacity at 60 °C lt/h	Heat Demand kcal/h	WIDTH A mm	LENGTH B mm	HEIGHT H mm	Hot Water (90/70) inlet-outlet inch	Cold Water (10/50) inlet-outlet inch	Steam at 4 bag inlet-outlet inch	Cold Water (10/60) inlet-outlet inch	Water Circulation inch	Thermostatic valve sensor inch
ÜSB 150	1.190	59.510	7.333	366.670	600	800	1400	2"	1/2"	2 1/2"	1 1/4"	1"	1 1/4"
ÜSB 300	2.332	116.615	14.370	718.516	700	900	1750	2 1/2"	3/4"	3"	1 1/2"	1 1/2"	1 1/4"
ÜSB 500	3.781	189.041	23.295	1.164.769	800	1000	2000	3"	1"	4"	2"	2"	1 1/4"
ÜSB 750	4.831	241.527	29.763	1.488.157	950	1150	2000	4"	1 1/4"	5"	2 1/2"	2 1/2"	1 1/4"
ÜSB 1.000	8.859	442.950	54.584	2.729.221	950	1150	2500	5"	1 1/2"	6"	3"	3"	1 1/4"
ÜSB 1.500	9.700	484.987	59.765	2.988.227	1150	1350	2400	6"	1 1/2"	6"	4"	3"	1 1/4"
ÜSB 2.000	12.378	618.898	76.266	3.813.315	1250	1450	2650	6"	2"	8"	4"	4"	1 1/4"
ÜSB 3.000	21.507	1.075.359	132.516	6.625.780	1300	1500	3400	8"	2 1/2"	8"	5"	4"	1 1/4"
ÜSB 4.000	22.299	1.114.947	137.394	6.869.704	1550	1750	3180	8"	2 1/2"	8"	6"	4"	1 1/4"
ÜSB 5.000	25.689	1.284.456	158.282	7.914.122	1650	1850	3500	10"	2 1/2"	10"	6"	5"	1 1/4"
ÜSB 6.000	33.336	1.666.820	205.401	10.270.043	1650	1850	4050	10"	3"	12"	8"	6"	1 1/4"
ÜSB 7.000	37.015	1.850.736	228.065	11.403.234	1750	1950	4150	10"	3"	12"	8"	6"	1 1/4"
ÜSB 8.000	46.646	2.332.323	287.410	14.370.514	1750	1950	4650	12"	4"	14"	10"	6"	1 1/4"
ÜSB 10.000	64.413	3.220.648	396.878	19.843.893	1750	1950	5650	14"	4"	16"	10"	8"	1 1/4"

* Dimensions may be changed without notice



İkitelli Organiza Sanayi Bölgesi Metal - İş Sanayi Sitesi
8. Ada No: 36 Başakşehir / İSTANBUL
Tel: 0212 549 70 70 • Fax: 0212 671 40 06
E-mail: info@universalkazan.com
www.universalkazan.com

HOT AIR BOILERS FOR HEATING PURPOSES

TYPE:SHK-I

Utilises steam, hot water, superheated water and thermal oil for producing sanitary hot water

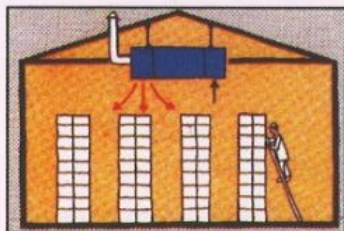

STORES AND SHOPS

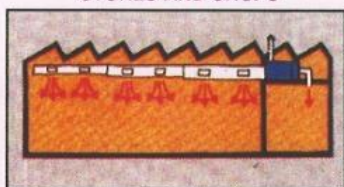

FACTORIES AND WORKSHOPS



GARAGES AND PASSENGER HALLS

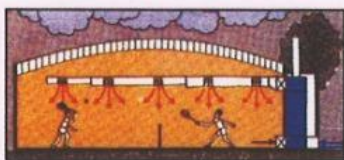

SPORT HALLS, SWIMMING POOLS
MOSQUES, CHURCS, ETC.

Hot air boilers are good solution for heating and ventilating purposes in plants, sport halls, swimming pools, passenger halls, big restaurants, mosques, churches, greenhouses, poultry houses etc.

SUPERIORITIES TO OTHER HEATING SYSTEMS

- Has minimum installation cost
- Has minimum operation costs (fuel consumption is even 25% lower comparing to heating systems with hot water or steam)
- Installed very quickly and easily
- Starts heating immediately as the system is started up (thus saves fuel as much as possible)
- When the system is operated without starting burner, cooling is possible via air Exchange
- Humidifier can be fitted to eliminate the effects of dry air
- System operates safely and automatically. Air outlet temperature and the temperature of the heated location are controlled automatically
- Steel boiler sheet and steel tubes are used for construction



TYPE SHK-I - Capacity and Main Dimensions

Type	Heating capacity	Air flow rate m ³ /h, 15°C	Air outlet temperature (°C)	Width A (mm)	Length B (mm)	Height C (mm)	Stack diameter (mm)
SHK-I/100	100.000	8.000	55	1000	1300	2500	250
SHK-I/150	150.000	11.500	55	1000	1300	2500	250
SHK-I/200	200.000	15.000	55	1300	1700	3000	350
SHK-I/250	250.000	19.000	55	1300	1700	3000	350
SHK-I/300	300.000	23.000	55	1300	1700	3000	350
SHK-I/350	350.000	27.000	55	1770	2300	4100	450
SHK-I/400	400.000	30.000	55	1770	2300	4100	450
SHK-I/450	450.000	33.500	55	1770	2300	4100	450
SHK-I/500	500.000	37.000	55	1770	2300	4100	450
SHK-I/600	600.000	44.000	55	2400	3000	5150	550
SHK-I/700	700.000	49.000	55	2400	3000	5150	550
SHK-I/800	800.000	58.000	55	2400	3000	5150	550
SHK-I/900	900.000	69.000	55	2400	3000	5150	550
SHK-I/1000	1.000.000	72.500	55	2400	3000	5150	550

• For higher capacities, please contact us.
• Dimensions may be changed without notice



HEAT RECOVERY SYSTEM FROM WASTE ENERGY



3,3 T/h, 6 Atü



WASTE HEAT RECOVERY BOILER
Boiler Çimsa Cement - Kayseri



HEAT ENERGY RECOVERY SYSTEMS FROM HOT SMOKE GASES INSTALLED IN THE CHIMNEY



TYPE: E-DG

HEAT RECOVERY BY USING AN ECONOMIZER FROM THE FLUE GAS INSTALLED IN THE CHIMNEY OF FUEL OIL BOILERS The recovery is up to 7.5%.

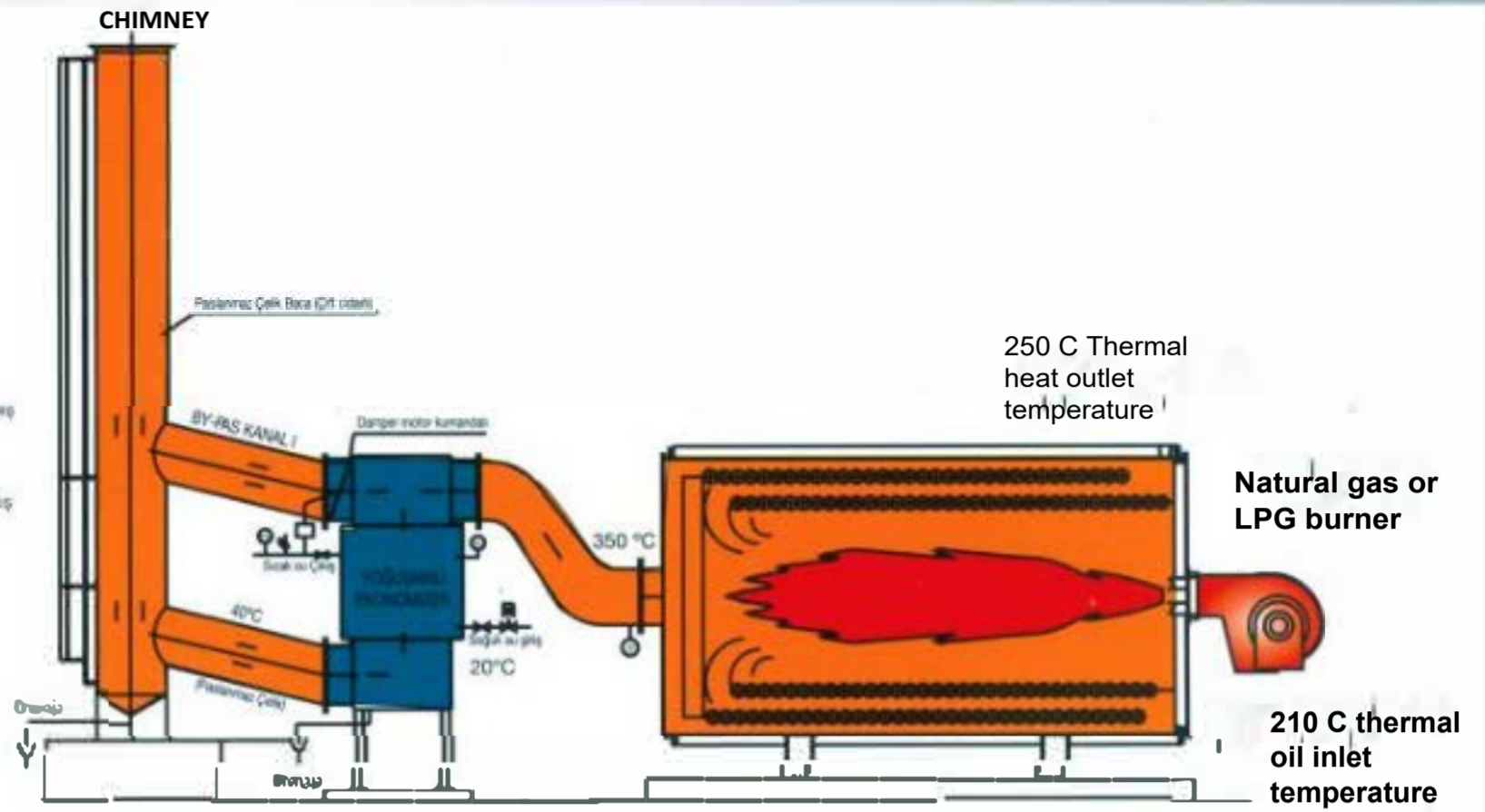
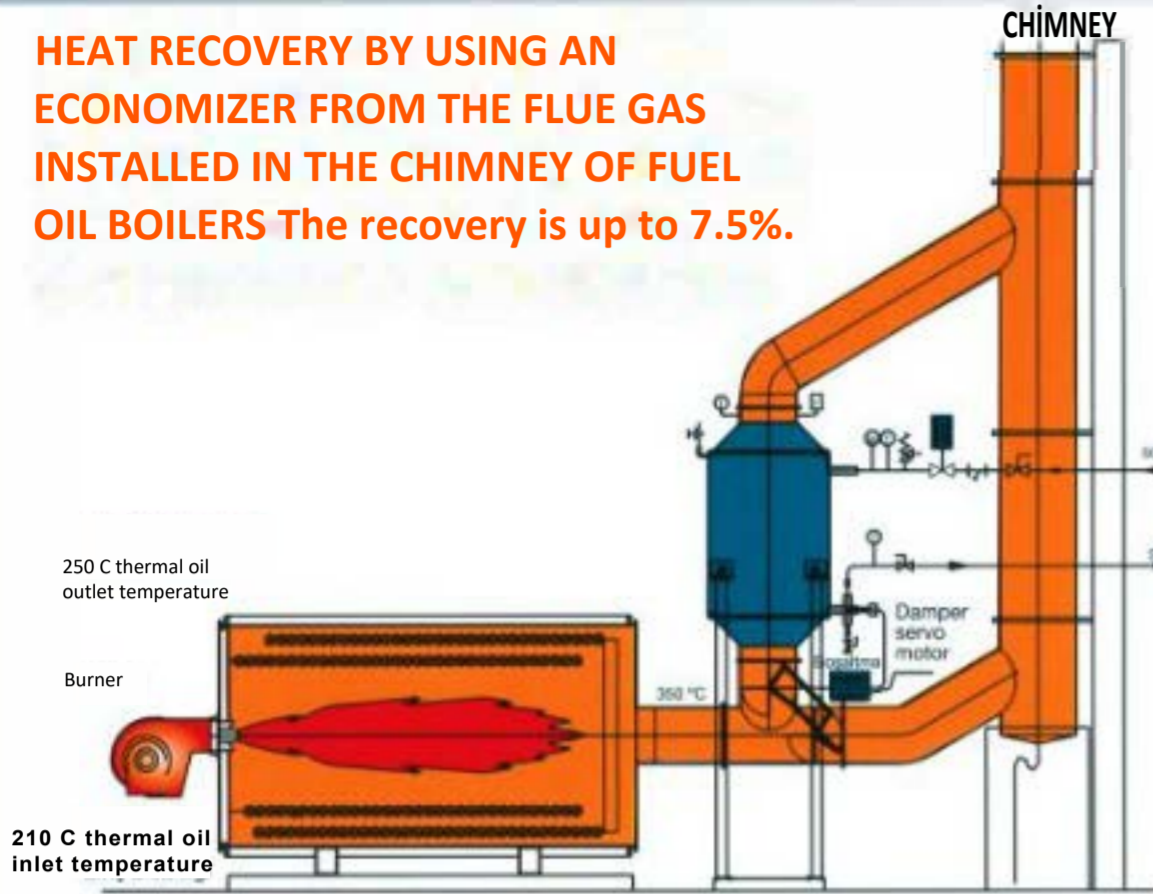

IN THERMAL OIL BOILERS

Flue gas temperature installed in the chimney; Approximate thermal oil outlet temperature is + 100°C. In the example above, it is 350°C.

HEAT RECOVERY USING A FLUE GAS CONDENSING ECONOMIZER ATTACHED TO THE CHIMNEY IN HOT OIL BOILERS THAT BURN NATURAL GAS

Recovery is up to 20%.

THERMAL OIL BOILER WITH COMBUSTION AIR HEATER

In natural gas combustion, by means of the combustion air heater added to the hot oil boiler, the smoke gas temperature can be reduced to 120°C, while the combustion air temperature can be increased to 250°C.

Boiler efficiency increases by 11.5%.

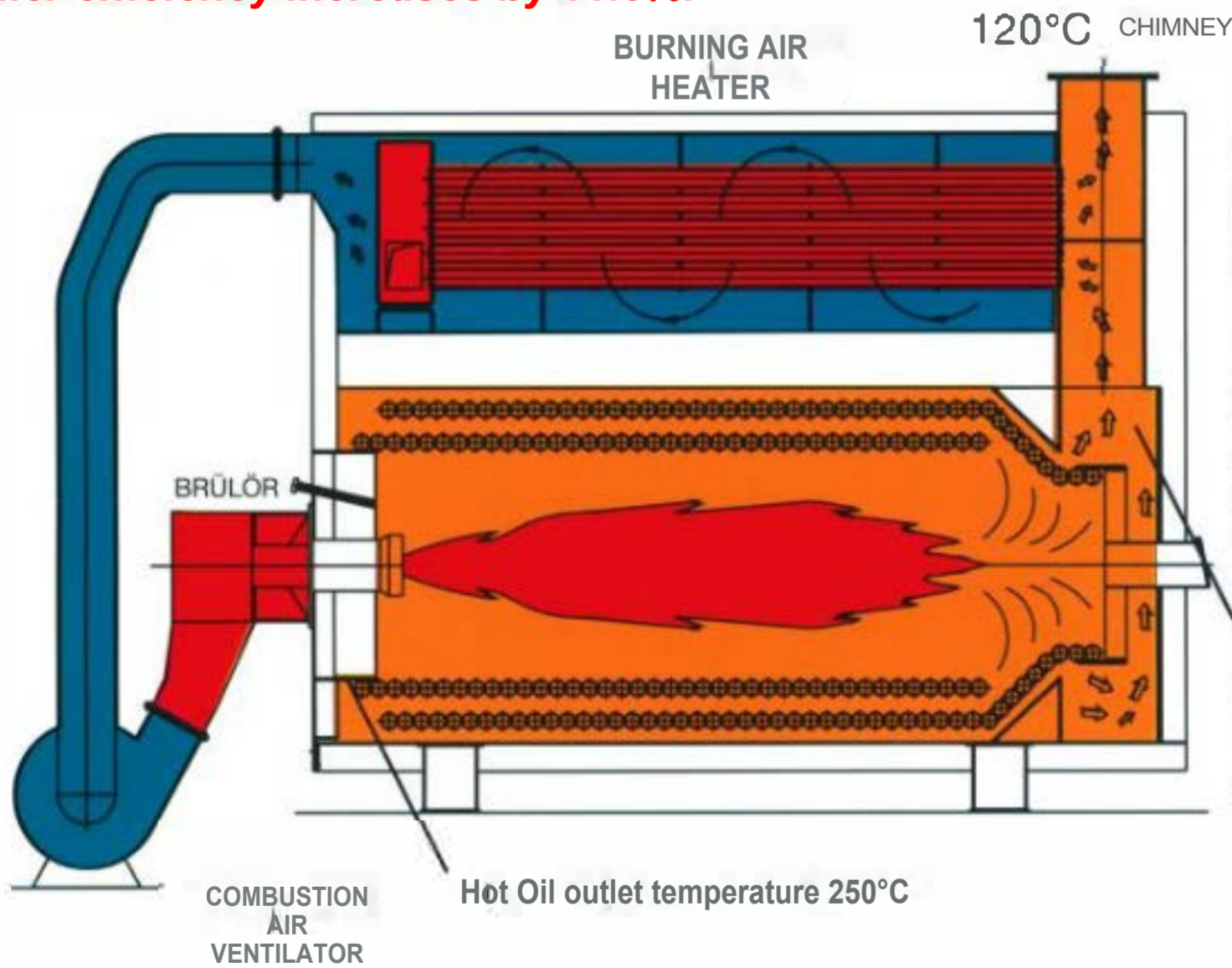

The smoke gas temperature coming out of the boiler is 350 C.

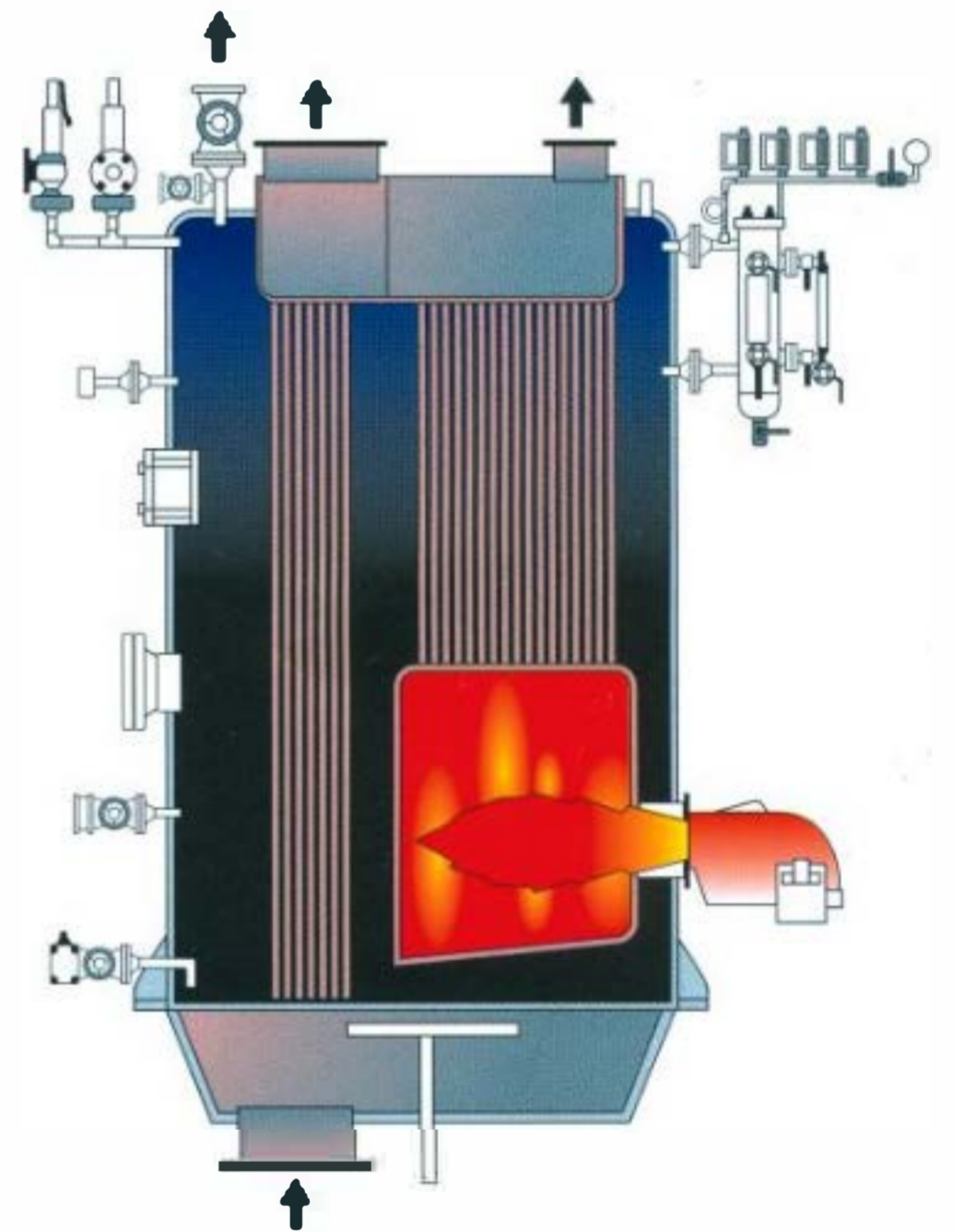

500 ... 600°C flue gas
Steam producing, burner reinforced waste heat boiler
(Vertical type)

WASTE HEAT RECOVERY STEAM BOILER (Horizontal Type)



STONE KILN OR COGENERATION PLANT

SMOKE GAS->

600 C

150 C

WASTE HEAT RECOVERY SYSTEMS

FREE
ENERGY



From waste hot gases (200° C); Our waste heat boiler producing 4.2 t/h, 7 bar steam As Çimento - Antalya



Please contact our company for detailed information.

ÜNİVERSAL KAZAN

Adres: Ziya Gökalp, Metal İş Sanayi Sitesi Yolu
8.Blok No:36-38, 34490 İkitelli Osb/Başakşehir/İstanbul
Telefon: (0212) 549 70 70
info@universalkazan.com.tr
www.universalkazan.com.tr



Machinery and Heat
Industry



HEAT ENERGY RECOVERY SYSTEMS FROM HOT SMOKE GASES INSTALLED IN THE CHIMNEY TYPE:E-DG

In steam boilers, hot oil boilers, glass or similar melting or drying furnaces, cogeneration facilities through hot gases thrown into the chimney; By heating boiler feed water, central heating water, domestic hot water, process water; or burning. Recycling is achieved by heating air, ambient air and process air. **It should not be forgotten that every 20°C temperature decrease of the hot smoke gas discharged into the chimney increases the device efficiency by 1%.**

STRUCTURE OF HEAT RECOVERY DEVICES:

It is manufactured in different designs depending on the usage conditions and the characteristics of the fuel burned. Depending on the usage conditions, economizers can be made of straight seamless pipe, finned pipe, 316L stainless steel pipe; It is made of straight pipe and hairpin-shaped finned pipe with or without reserve.

HEAT RECOVERY FROM THE FUSE GAS PUSHED INTO THE CHIMNEY DURING FUEL OIL BURNING USING AN ECONOMIZER

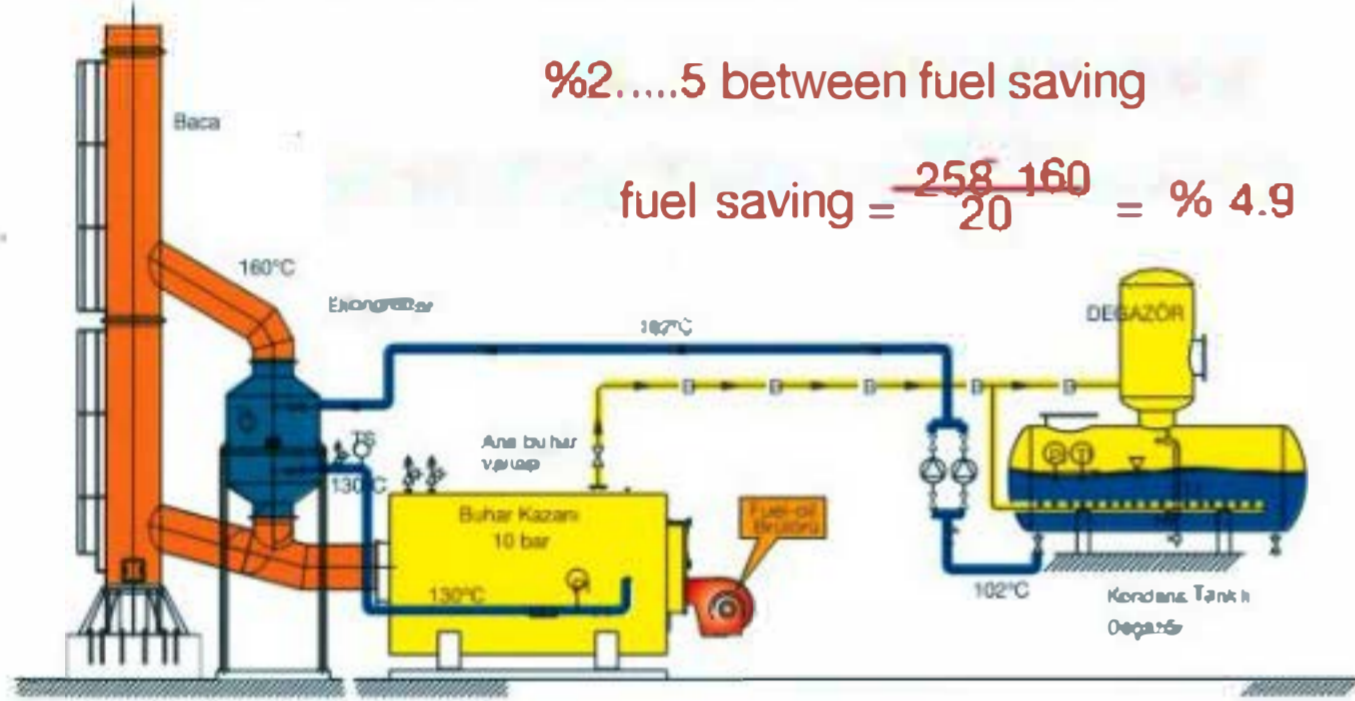

Ekonomizere giren duman gazı sıcaklığı = buhar sıcaklığı + (50 ... 70°C) = 258°C
 Water in boilers burning coal and fuel oil; economizer min. 70°C must enter at temperature. Otherwise, corrosion at the entry point occurs. The flue gas leaving the economizer is in sulfur coal. 180°C, 160°C in fuel oil, non-condensing in natural gas
 It should not be less than 120°C in the economizer.

HEAT RECOVERY USING A FLUE GAS CONDENSING ECONOMIZER INSTALLED IN THE CHIMNEY IN NATURAL GAS FIRING

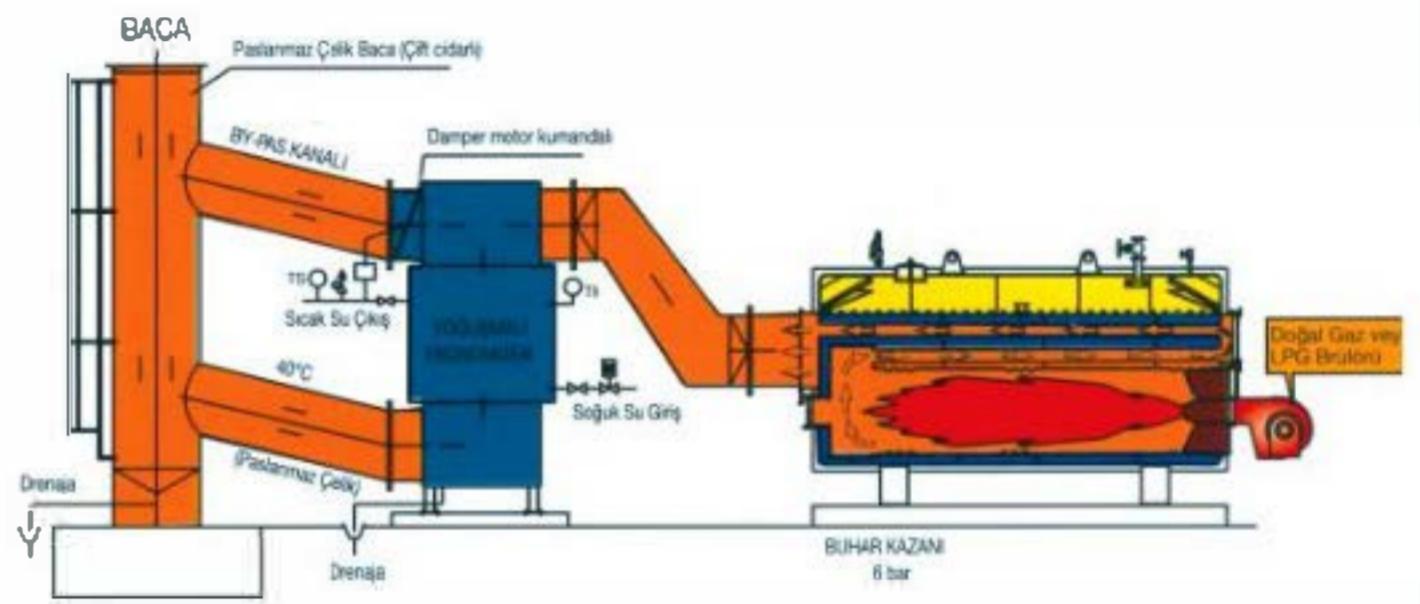

Boiler efficiency can be increased by up to 15.7% by using a condensing economizer in gas-fired boilers.

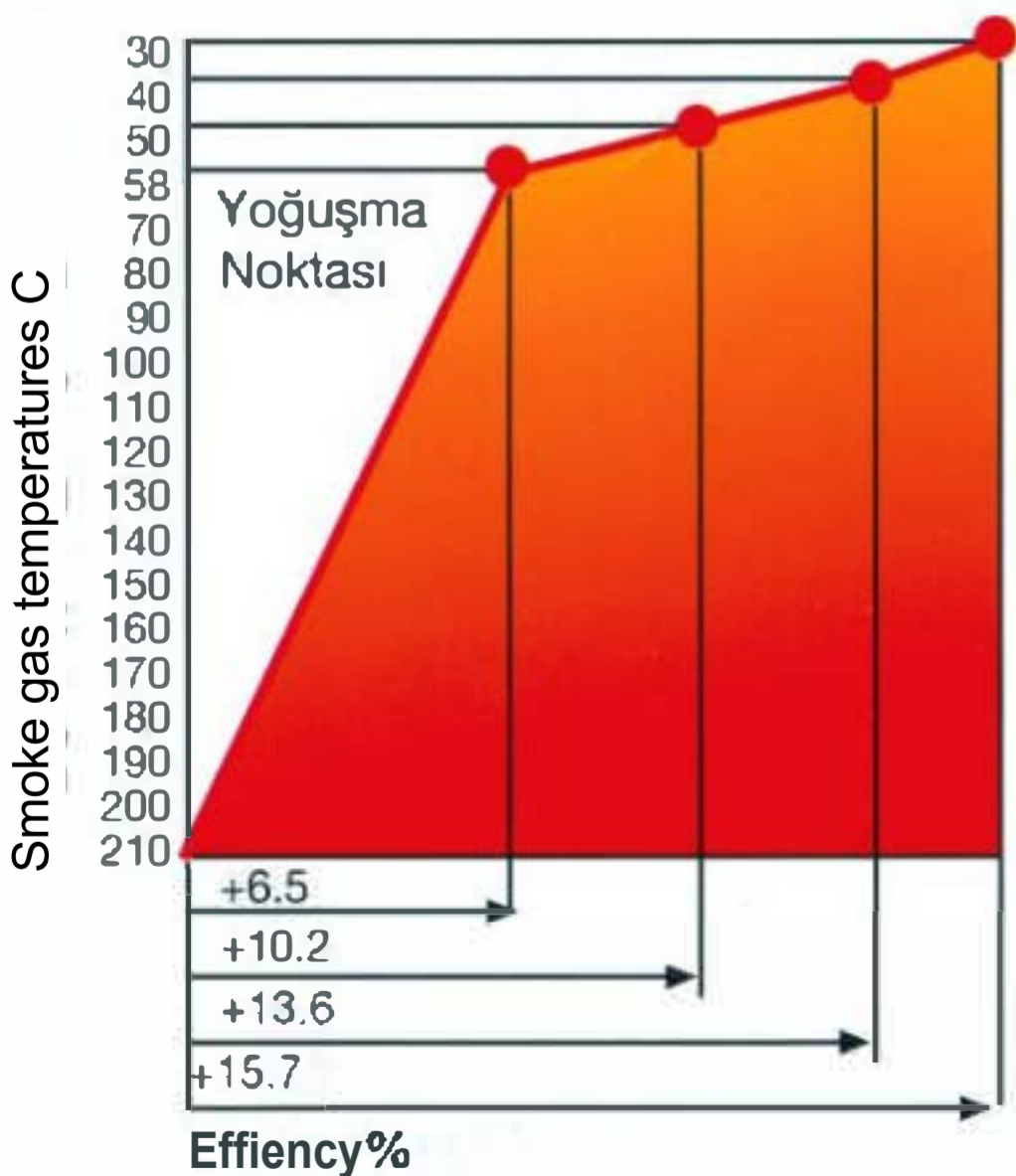

Skoc type at 6 bar operating pressure; The temperature of the smoke gas leaving a steam boiler burning natural gas is 210°C at full load, and the recovery (fuel saving) values obtained at different temperatures of the smoke gas leaving the economizer placed behind the boiler

Universal[®]



DEAERATOR

TYPE:Ü-KD

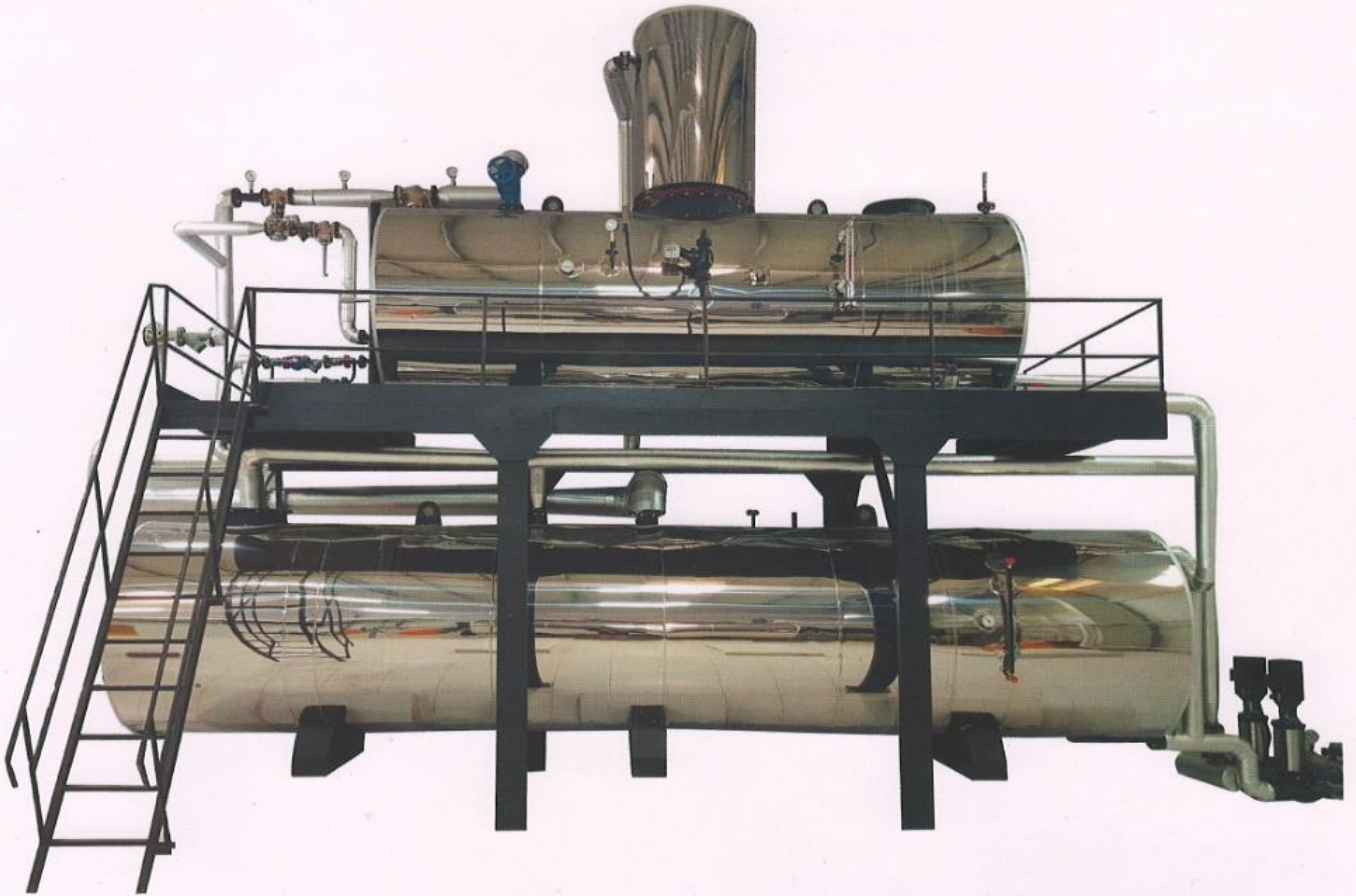

İkitelli Organiza Sanayi Bölgesi Metal - İş Sanayi Sitesi
8. Ada No: 36 Başakşehir / İSTANBUL
Tel: 0212 549 70 70 • Fax: 0212 671 40 06
E-mail: info@universalkazan.com
www.universalkazan.com

Universal[®]

KAZAN PAZARLAMA
ve TAAHHÜT LTD. ŞTİ.



CONVENTIONAL THERMAL DEAERATOR TYPE:Ü-KD (Thermic gas seperators)

For oxygen (O_2) and carbondioxide (CO_2) dissolved in feed water for steam boiler cause destruction on metal surfaces of both steam boiler and steam lines (Figure1 and Figure2). For the removal of these corrosive gasses, feed water is atomized and heated with steam, CO_2 and O_2 dissolve at $60\text{ }^\circ\text{C}$ and $100\text{ }^\circ\text{C}$, respectively (Figure3 and Figure4). Atomizing process is applied with sprinkling system at conventional deaerators.

Disadvantages of this system:

Water level inside the deaerator should be at least 6 meters above the suction side of feed water pump for avoiding evaporation and cavitation (Figure5). For this reason, height of the boiler room should be at least 10 meters. Additionally, supporting platform for the deaerator is needed. Thus construction cost of the boiler room increases.

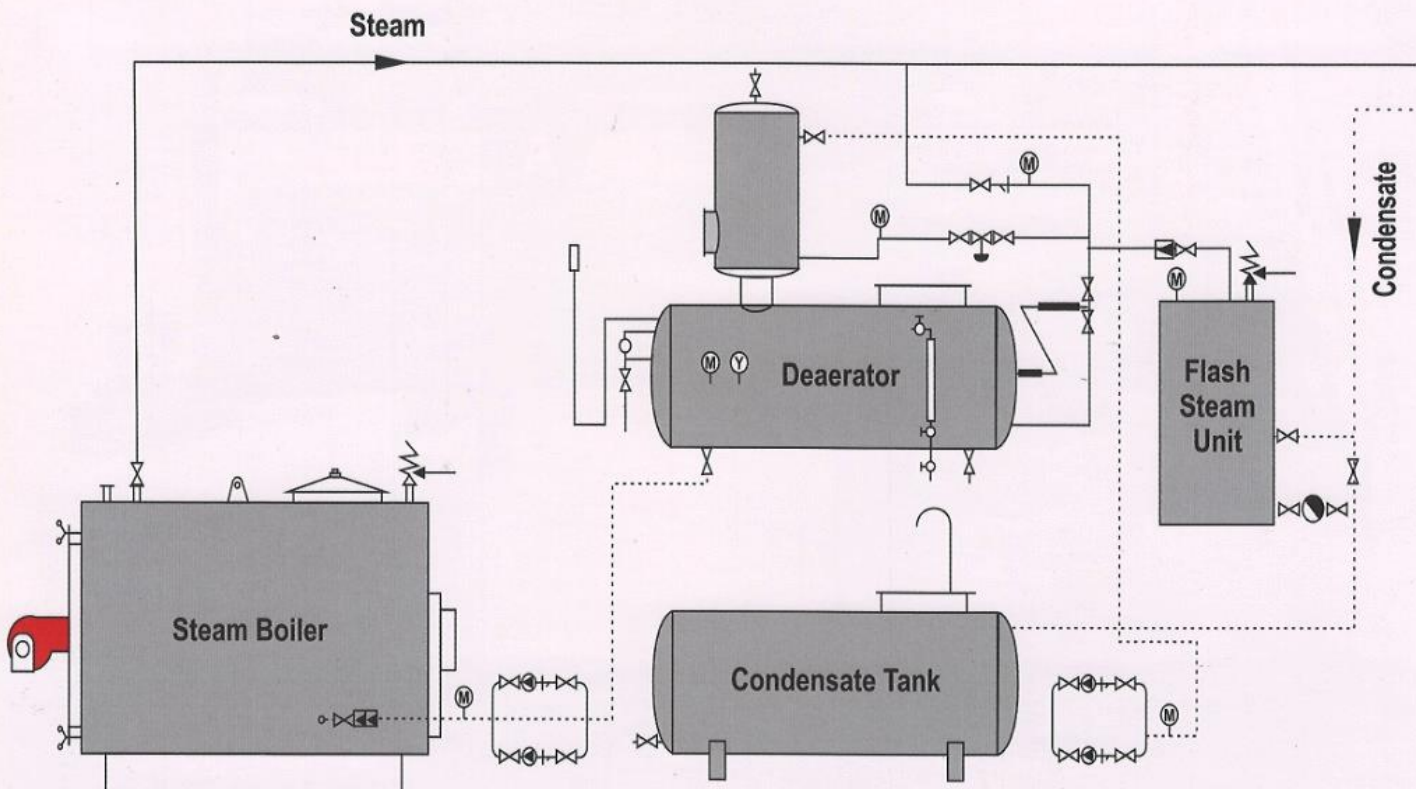

* Dimensions may be changed without notice