

Professional Products



HANGZHOU BYCON INDUSTRY CO.,LTD

#2 Building, No.58 XiangShan Road, XiaoShan District, Hangzhou, Zhejiang

✉ Email:info@bycongrp.com  www.bycongrp.com  T:+86-571-82563775
F:+86-571-82563765



Professional Diamond Tools & Machinery

2024
CATALOGUE

PROVIDE
**MACHINERY
DIAMOND TOOLS**

- CORE DRILL MOTOR • CORE DRILL RIG • FLOOR GRINDER
- INDUSTRIAL VACUUM CLEANER • FLOOR SAW • DIAMOND CORE BIT
- DIAMOND BLADE • GRINDING TOOL

HANGZHOU BYCON INDUSTRY CO.,LTD



**PROFESSIONAL
DIAMOND
TOOLS &
MACHINERY**

**“BRAVE
YOUNG
NON-STOP
INNOVATION
COMMUNICATION!
PEOPLE-CENTERED
QUALITY FIRST !”**

BYCON GROUP

Since the company began in 2005, Bycon has led the industry in developing innovative solutions for professional drilling, grinding, cutting & sawing . We produce high quality diamond drill motor, diamond drill rig, floor grinder, floor saw and diamond tools etc.

Working side-by-side with real users to understand the demands of a constantly changing workplace, and Bycon created DMP series drill motor with smart warning system LCD screen to make drilling job safer and more productive jobsite.

Bycon has been adhering to the" People-centered, Quality first" business philosophy. We will continue on the path of development and innovation. Bycon is not only a manufacturer, but also an IDEA Factory!



OUR DEVELOPMENT

We export near 95% products to the global markets with more than 20 Bycon agents, BYCON is dedicated to the optimization and innovation of professional diamond machinery and tools technology with big passion.

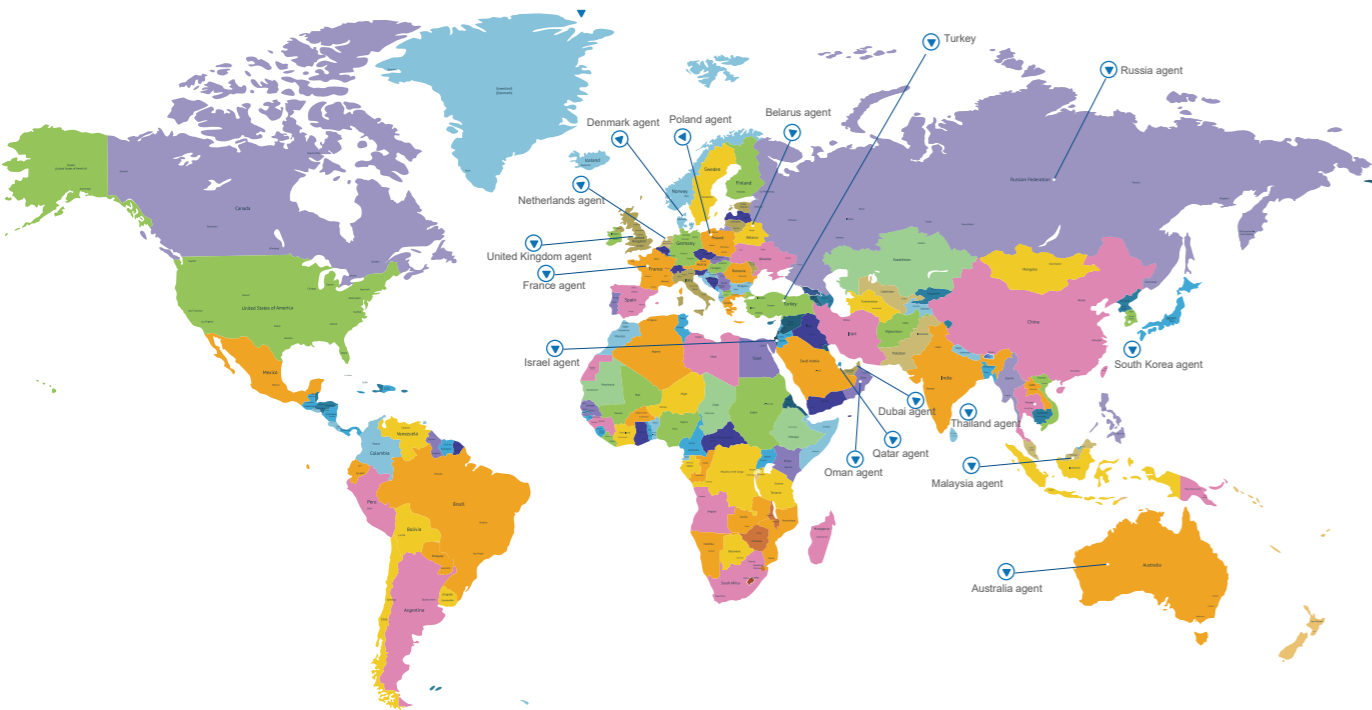

INNOVATION



Innovation is the driving force for our progress. We always adhere to scientific and technological innovation leading the development of the industry.

PROFESSIONAL PRODUCTS



Product line: drill motor, floor grinder, floor saw and diamond tools etc.

ODM SERVICE



We can support ODM service to customize our range new products.



<p>1 CORE DRILL MOTOR Holding smart warning system core drill motor series ,easy operation</p>	<p>2 CORE DRILL RIG Quick release mounted style,it's suitable for most brand drill motor</p>	<p>3 CORE BITS Laser welded wet and dry drilling core bits</p>
<p>4 FLOOR GRINDER Grinding,preparing, polishing of concrete floors as well as natural stones etc</p>	<p>5 VACUUM CLEANER High efficient way to protect you from dust and slurry by Bycon vacuum cleaner</p>	<p>6 FLOOR SAW Decades of experience in the production of floor saw</p>
<p>7 GRINDING TOOLS Revolutionary grinding tools for customized design</p>	<p>8 DIAMOND BLADES Floor sawing diamond blades cover most applicants , ranging from sawing asphalt to sawing in heavily reinforced concrete</p>	

BYCON GROUP

Hangzhou Bycon Industry Co.,Ltd is a leading manufacturer of concrete construction machines and diamond tools in China. As an ISO9001: 2015 certificated company, we produce high-quality electrical machines and diamond tools to customers, especially in diamond core drills, drill rigs, floor grinders, diamond core bits, diamond blades etc.

Bycon started its business in 2005 as a China Germany joint venture to combine the new German technology with Chinese manufacturing. In 2015, Bycon established its own brand-oriented way with new Made-in-China products to worldwide, especially in construction field. With years development and long-term growth, Bycon is with full capacity to bring innovation, professionalization and advantages of Made-in-China to overseas in terms of the performance of electric tools.

With three factories for each niche product ranges, Bycon ensures manufacturing procedures can be well-managed and products quality can be guaranteed from components to finished tools. Exported more than 40 countries, we have 20 Bycon agents around the world for better service, quicker response, mutual win cooperation. We're going to cooperate with more distributors in high-end market to complete Bycon dealers network.

Honored brands

- Bycon -- Concrete construction machines and diamond tools
- Thrall -- Petrol tools
- Dekola -- For promoting our products in domestic market
- Dry Bird -- Micro-percussion core drills and impact core bits
- Betteri -- Diamond machinery and tools online brand

Established international business as China Germany joint venture mainly focus on drill motor developing and manufacturing.

2005

Completed diamond core drilling accessories.

2010

Established Bycon diamond tools factory.

2017

Launched new series core drills with LED warning system and innovative LCD.

2019

Developing micro-percussion core drill series at Brand Dry Bird

2022

BUSINESS UNITS



BYCON Tools

Concrete construction machines and diamond tools.



DEKOLA Tools

Concrete construction machines and diamond tools for domestic market.



DRY BIRD Tools

Dry drilling solution machines and diamond tools.



BETTERI Tools

Hardware tools and diamond tools for commercial.



THRALL Tools

Petrol tools machines including post driver, jack hammer etc.

CONTENTS

11

01 Core Drill Motor

Micro percussion dry drill motor
Hand held wet & dry drill motor without micro percussion
Rig mounted wet drill motor without micro percussion

61

03 Floor Grinder

Grinding,preparing, polishing of concrete floors as well as natural stones etc.
Edging grinder to diameter 250mm
Mid duty grinding to diameter 480mm

75

05 Floor Saw

Walk behind floor saw in light duty
350mm/ mid duty 500mm cutting job

99

07 Diamond Blade

ECO universal diamond blades
PRO universal diamond blades
Concrete diamond blades
Asphalt diamond blades
Superfine prealloy diamond blades
Wall saw diamond blades
All cutting diamond blades
Tile cutting diamond blades
STR concrete diamond blades
Diamond wire

45

02 Core Drill Rig

Light duty job drill rig max. 252mm diameter
Heavy duty job drill rig max. 500mm diameter
Special drill rig for 2meter length

73

04 Industrial Vacuum Cleaner

79

06 Diamond Core Bit

Laser welded wet and dry drilling core bits.
Wet drilling
Dry drilling
Dry micro percussion drilling

107

08 Grinding Tool

Revolutionary grinding tools for customized design
PCD grinding shoes /cup wheel / Polishing pads
Diamond grinding shoes/ cup wheel/ pad



Core Drill Motor



DB-352

DB-132

DB-202D

DB-162D

DMP-52D

DMP-132P

DMP-162D

DMP-500

DMP-202P

DMP-52P

DMP-352

DB-162P

DMP-252

DB-202P

DMP-132D

DMP-162P



DMP-202D

DMP-252B

Bycon Core Drill motor General List

Bycon holds three series drill motors: DB micro-percussion drill motor, DMP hand held drill motor, DMP rig mounted type drill motor.

DB Micro percussion drill motor series is the solution for dry drilling applications in reinforced concrete, High efficiency!

■ Wet drilling  Reinforced concrete
■ Dry drilling  Micro-percussion mode  Brushless motor

DB MICRO PERCUSSION SERIES

*Brushless
DB-132





 ■ 132mm

*Brushless
DB-202D





■ 202mm
■ 202mm

*Brushless
DB-202P





■ 202mm
■ 202mm

DB-162D





■ 132mm
■ 162mm

DB-162P





■ 132mm
■ 162mm

DB-352





■ 302mm
■ 302mm

DMP SERIES

*Brushless
DMP-202BD





■ 202mm
■ 202mm

*Brushless
DMP-202BP





■ 202mm
■ 202mm

*Brushless
DMP-252B





■ 252mm

Rated power

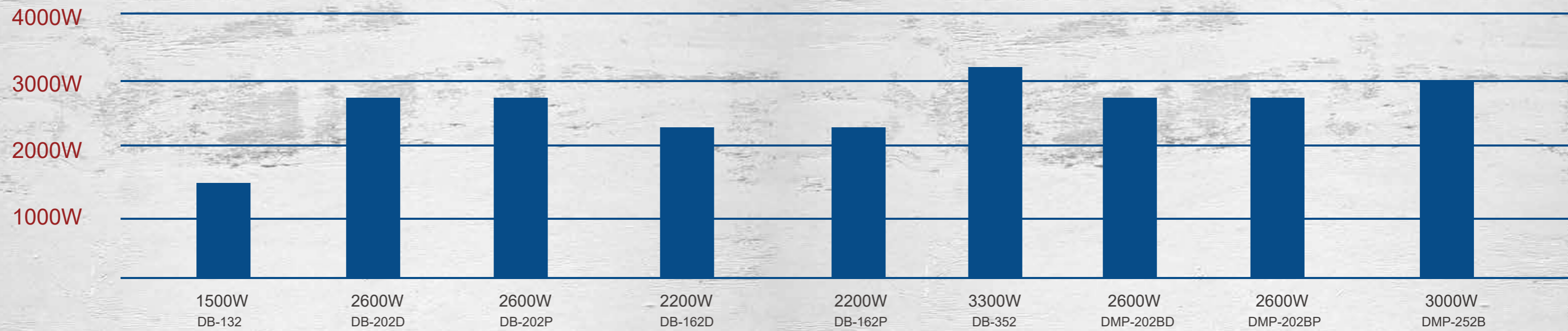

Bycon Core Drill motor General List

Bycon holds three series drill motors: DB micro-percussion drill motor, DMP hand held drill motor, DMP rig mounted type drill motor.

DB Micro percussion drill motor series is the solution for dry drilling applications in reinforced concrete, High efficiency!

■ Wet drilling reinforced concrete
■ Dry drilling

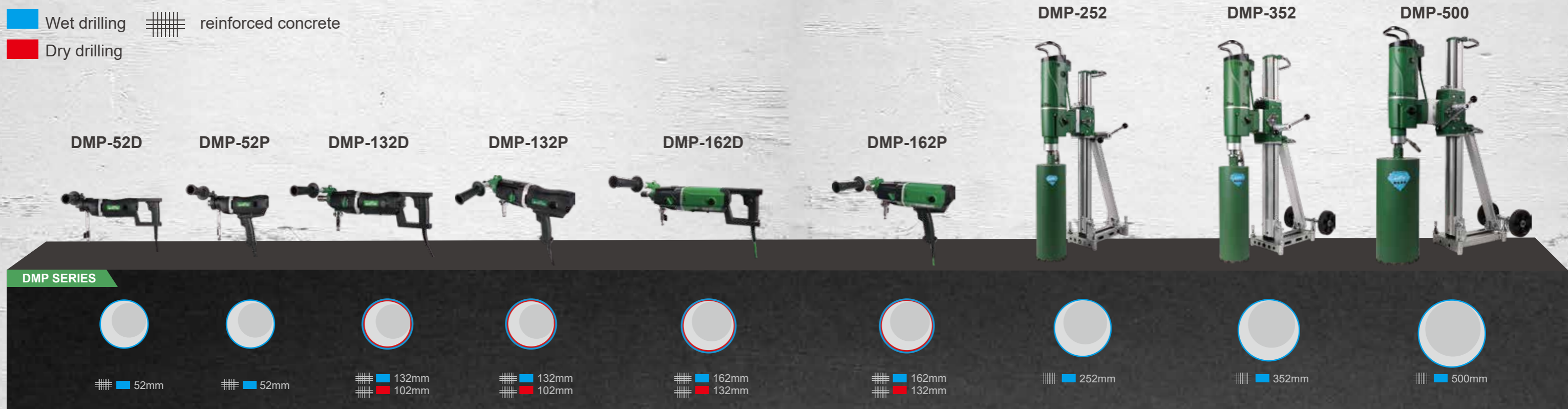

Rated power

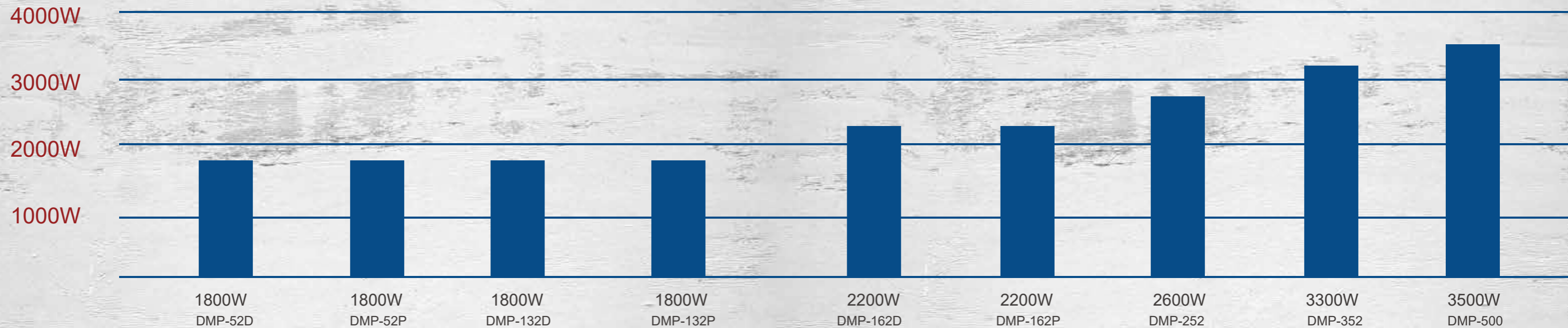



Micro-Percussion Drill Motor

Featured Micro-Percussion mode can be turned on and off using the mode select ring on the spindle. With it on, the built-in percussion hammering mechanism will let the whole spindle with drill bit move forward and backward on the axis of rotation. It will significantly increase the drill speed and efficiency when core drilling.

DB-132 DB-162D DB-162P DB-202D DB-202P DB-352

Brushless **DB-132** *new launch in 2023 Micro-Percussion Drill Motor

This type of motor is the most relevant and necessary for:

- electricians / air conditioner installers
- heating and gas installers
- as well as for installers of video surveillance systems and others



- BRUSHLESS MOTOR
- MICRO-PERCUSSION MODE
- LED INDICATOR LIGHT
- DRY OPERATION
- NORMAL MODE
- CONSTANT RPM/AMP/POWER

Model	DB-132	
Art No.	1223132	
Power	1500W	
Voltage	230V	110V
Current	10A	15A
N.W	3.7KG	
Frequency	50-60HZ	
Max Drilling Diameter	132MM	
No-Load Speed	1500/3000RPM	
No-Load Impact Speed	24000/48000BPM	
Spindle Thread	M18	

STANDARD EXTRACTOR ADAPTOR

Standard adaptor in package to help dry drill with M16 electric socket drill bits.



DRILL WITHOUT DUST

Installation with 38L vacuum cleaner, it will dry drill without dust.

Recommended core bit for socket boxes Φ 68, 72 and 82 mm diameters range for DB-132.



OPTIONAL EXTRACTOR ADAPTOR

Recommended core bit for (depending on material):

- Φ 32-52 mm - for heavy reinforced concrete B35-B50 with granite and silicon filler (including core bits for socket boxes Φ 68, 72 and 82 mm)
- Φ 32-72 mm - for lightweight concrete B22.5-B30
- Φ 32-102 mm - for bricks and other light materials.

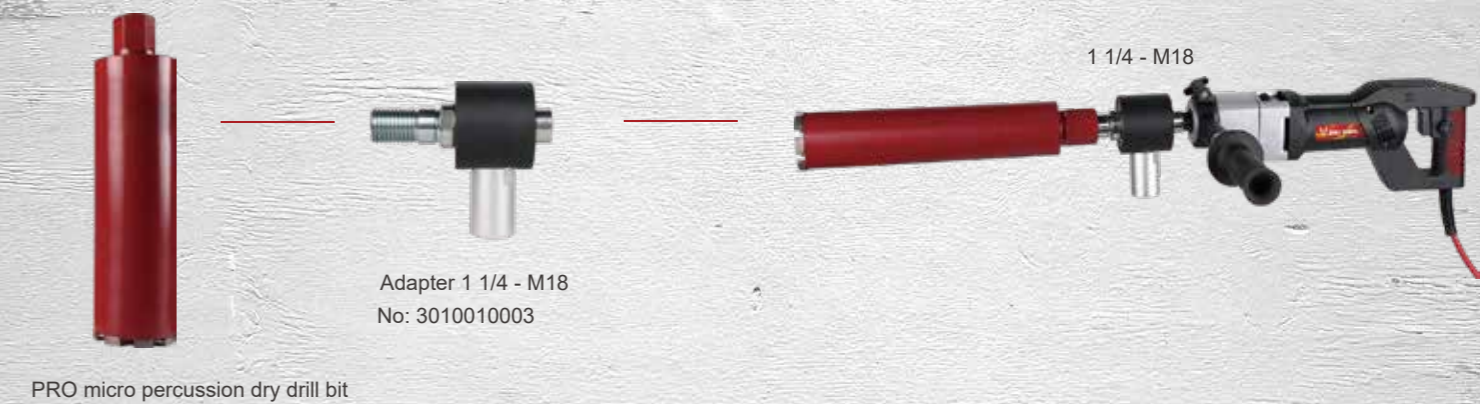

PACKAGE



ACCESORIES

- 1 x Depth gauge measuring rod
- 1 x Wrench: 22 & 24mm
- 1 x instruction manual book
- 1 x maintenance manual book
- 1 x Anti-vibration adjustable handle
- 1 x SDS Plus pilot drill bit (8x150mm)
- 1 x Adapter M18x2.5 to SDS Plus M16
- 1 x Blow mould case



Micro-Percussion Drill Motor

Featured micro-percussion function accelerates dry drilling reinforced concrete work progress. Electronics for soft start and LED indicator for optimum drilling performance. Also, it's suitable for wet drilling when you need.

DB-162

*new launch in 2023



► APPLICATION

Dry core drilling diam. up to 162mm on hard construction materials like reinforced concrete, crushed limestone with high efficiency. Suitable for drilling holes for HVAC (heating, ventilation and air-conditioning) installation work. Electrician's professional helper on installing of plug outlets and junction boxes.

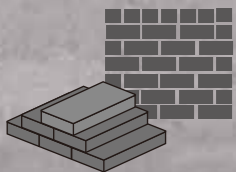

Brick

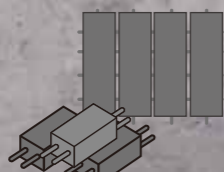

Reinforced concrete



Micro-Percussion core bit



Drill without dust

Please use with vacuum cleaner AVC-38HEPA which is suitable for wet & dry drilling job condition both for DB-162 series.

Specification

Model	DB-162P		DB-162D	
Art No.	1223162		1224162	
Power	2200W		2200W	
Voltage	230V	110V	230V	110V
Current	10A	15A	10A	15A
N.W	6.5KG		6.5KG	
Frequency	50-60HZ		50-60HZ	
Max Portable Drilling Diameter	162MM		162MM	
Max Drilling Diameter & Stand	202MM		202MM	
No-Load Speed	640/1420RPM		640/1420RPM	
No-Load Impact Speed	14040/31200BPM		14040/31200BPM	
Spindle Thread	1-1/4" UNC & 1/2"G		1-1/4" UNC & 1/2"G	
1,2 gear drilling diameter	162/76MM		162/76MM	
1,2 gear drilling diameter with stand	202/102MM		202/102MM	
Compatible stand	DSP-162&DSP-252		DSP-162&DSP-252	

Brushless Micro-Percussion Drill Motor DB-202 Series

The new DB-202D & DB-202P Drilling Machine features a brushless motor, micro-percussion mode, a maximum drilling diameter of 202mm, and 2600W power. Perfect for both dry & wet drilling, it effortlessly handles all your construction needs.

DB-202D

DB-202P

*new launch in 2024



DB-202 Series

Micro-Pr Percussion drill motor

- MICRO-PRERCUSSION MODE
- NORMAL MODE
- BRUSHLESS MOTOR
- WET/DRY OPERATION
- LED INDICATOR LIGHT

recommended core drill rig



DBS-162



Specification

Model	DB-202P		DB-202D	
Art No	1223202		1224202	
Power	2600W		2600W	
Voltage	230V	110V	230V	110V
Current	14A	25A	14A	25A
N.W	6.05KG		6.05KG	
Frequency	50-60HZ		50-60HZ	
Max.Drilling Diameter	202MM		202MM	
Speed	700/1550RPM		700/1550RPM	
Impact Speed	16800/37200 BPM		16800/37200 BPM	
Spindle Thread	1-1/4" UNC&1/2G		1-1/4" UNC&1/2G	
1,2 Gear Drilling Diameter	202/102MM		202/102MM	
Compatible Stands	DBS-162		DBS-162	
Packing Size	635 x 460 x 215MM		635 x 460 x 215MM	

*new launch in 2024

Micro-Percussion Drill Motor **DB-352**

Heavy duty drill up to 302mm, equipped with wet and dry, drilling in Reinforced Concrete / Concrete / Stones / Asphalt / Masonry / Bricks.



MICRO-PRERCUSSION MODE



WET/DRY OPERATION



THREE SPEEDS



LCD DISPLAY



Smart LCD Display



DB-352

recommended core drill rig



DBS-352

Product Details



Specification

Model	DB-352	
Art No	1223352	
Power	3300W	
Voltage	230V	110V
Current	16A	25A
N.W	18KG	
Frequency	50-60HZ	
Max.Drilling Diameter	302MM	
Speed	512/1062/1576RPM	
Impact Speed	12288/25488/37824BPM	
Spindle Thread	1-1/4" UNC	
1,2,3 Gear Drilling Diameter	302/202/102MM	
Compatible Stands	DBS-352	
Packing Size	755 x 200 x 275MM	



DMP Series Hand Held Drill Motor

Featured with smart LED warning system for all DMP series hand held drill motor, light weight and high efficiency drilling job range from diameter 10mm to 202mm.







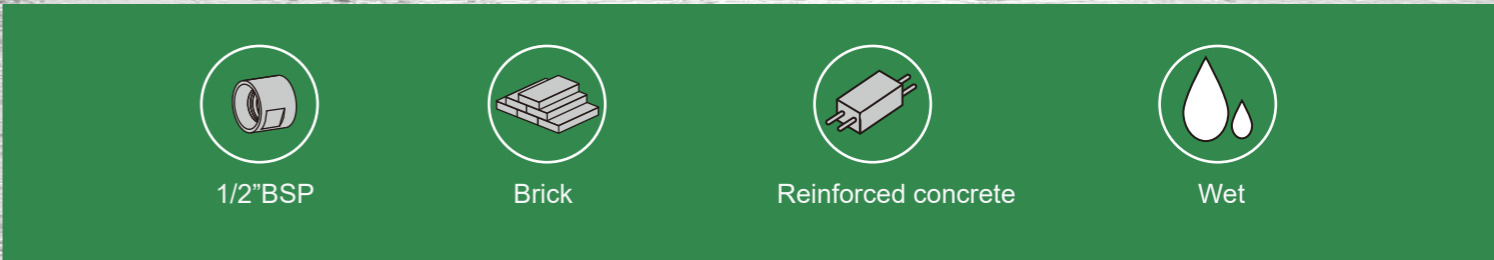

DMP-52P

DMP-52D

*new launch in 2023



Wet diamond core drill motor

-  Soft start
-  LED indicator light
-  Compact: 5.6kgs

Red light on: Overload Yellow light on: Overheat
 Red & Yellow light on: Replacement carbon brush

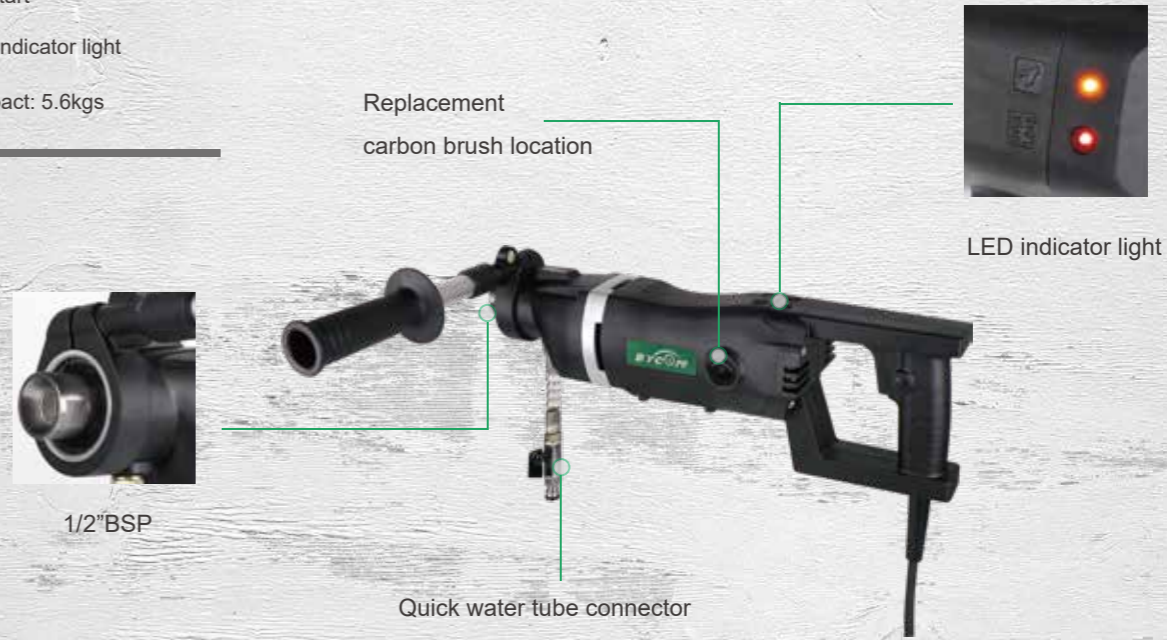

Hand-held Drill Motor DMP-52 Series

A compact 1 speed 1800W wet drilling motor designed for fast wet drilling of small diameters from 10 mm up to 50 mm in brick and concrete. Smart LED indicator light hold warning of overload,overheat and carbon brush replacement.

Specification

Model	DMP-52P		DMP-52D	
Art No.	1123052		1124052	
Input Power	1800W		1800W	
Voltage	230V	120V	230V	120V
Current	9A	15A	9A	15A
N.W	5.6KG	5.65KG	5.6KG	5.65KG
Frequency	50-60HZ		50-60HZ	
Max Portable Drilling Diameter	52MM		52MM	
Max Drilling Diameter & Stand	82MM		82MM	
Speed	2500RPM		2500RPM	
Spindle Thread	1/2\"/>			

Hand-held Drill Motor

DMP-132 Series

It's an ideal model for light duty hand held drilling job at weight 6.8kgs. This model can be wet and dry drilling in different materials at 1800W High-performance motor.



DMP-132P

*new launch in 2023

DMP-132D

Specification

Model	DMP-132P		DMP-132D	
Art No.	1123132		1124132	
Input Power	1800W		1800W	
Voltage	230V	110V	230V	110V
Current	9A	15A	9A	15A
N.W	6.8KG	6.85KG	6.8KG	6.85KG
Frequency	50-60HZ		50-60HZ	
Max Portable Drilling Diameter	132MM		132MM	
Max Drilling Diameter & Stand	162MM		162MM	
No-Load Speed	650/1300/2600RPM		650/1300/2600RPM	
Spindle Thread	1-1/4" UNC & 1/2"G		1-1/4" UNC & 1/2"G	
1,2,3 gear drilling diameter	132/76/35MM		132/76/35MM	
1,2,3 gear drilling diameter with stand	162/92/52MM		162/92/52MM	
Compatible stand	DSP-162&DSP-252		DSP-162&DSP-252	
Packing size	635x460x215MM		635x460x215MM	

DMP-132D

A specially P & D designed heavy duty 1800w motor with 3 speed for dry & wet drilling in portable and mounted type optional up to 162mm. Smart LED indicator light hold warning of overload,overheat and carbon brush replacement.

- Wet operation
- Dry operation
- Three speed
- Soft start
- LED indicator light

recommended core drill rig

DSP-162

DSP-252





Hand-held Drill Motor DMP-162 Series

DMP-162 series drill motor can be operated by both hand-held and rig-mounted method, while as a premium series, quick-disconnect couplers for dry and wet drilling are standard accessories for variety of light-duty coring jobs.

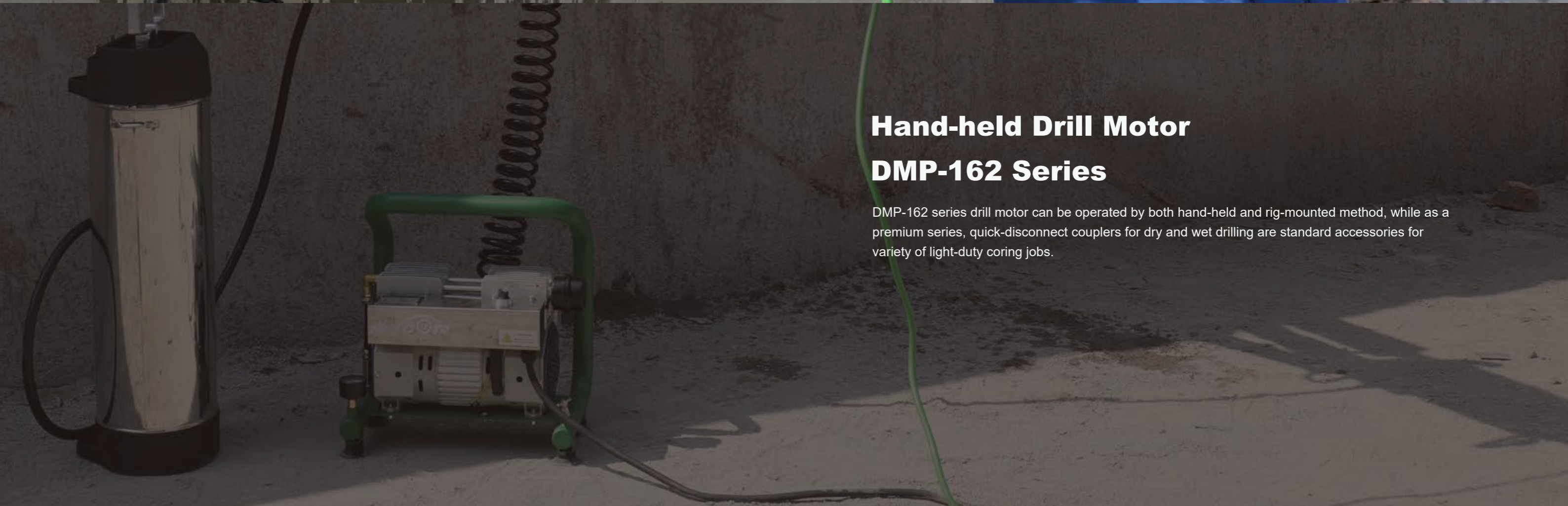



DMP-162 Series

DMP-162 series is featured with overload and overheat electric warning system to protect . Three speed for drilling job range from 10mm to 202mm diameter. It's classic models for professional diamond drilling field.



DMP-162 Series

Wet & Dry diamond core drill motor

-  Wet operation
-  Dry operation
-  Three speed
-  Soft start
-  LED indicator light

recommended core drill rig



DSP-162

DSP-252



Red light on: Overload Yellow light on: Overheat
Red & Yellow light on: Replacement carbon brush

Specification

Model	DMP-162P		DMP-162D	
Art No.	1123162		1124162	
Input Power	2200W		2200W	
Voltage	230V	110V	230V	110V
Current	10A	15A	10A	15A
N.W	7.5KG	7.7KG	7.8KG	7.9KG
Frequency	50-60HZ		50-60HZ	
Max Portable Drilling Diameter	162MM		162MM	
Max Drilling Diameter & Stand	202MM		202MM	
No-Load Speed	650/1300/2600RPM		650/1300/2600RPM	
Spindle Thread	1-1/4" UNC & 1/2"G		1-1/4" UNC & 1/2"G	
1,2,3 gear drilling diameter	162/82/42MM		162/82/42MM	
1,2,3 gear drilling diameter with stand	202/102/62MM		202/102/62MM	
Compatible stand	DSP-162&DSP-252		DSP-162&DSP-252	
Packing size	635x460x215MM		635x460x215MM	

Brushless Drill Motor DMP-202B Series

A specially DMP-202BP & DMP-202BD designed heavy duty 2600w motor with 3 speed for dry & wet drilling in portable and mounted type optional up to 202mm. Smart LED indicator light hold warning of overload,overheat and brushless replacement.

DMP-202BD

DMP-202BP

*new launch in 2024



DMP-202B Series

Brushless Drill Motor

BRUSHLESS MOTOR

WET/DRY OPERATION

THREE SPEED

LED INDICATOR LIGHT

Red light on: Overload Yellow light on: Overheat
Red & Yellow light on: Replacement carbon brush



recommended core drill rig

DSP-162

DSP-252



Specification

Model	DMP-202BP		DMP-202BD	
Art No	1123202		1124202	
Power	2600W		2600W	
Voltage	230V	110V	230V	110V
Current	14A	25A	14A	25A
N.W	6.65KG		6.65KG	
Frequency	50-60HZ		50-60HZ	
Max Drilling Diameter	202MM		202MM	
Speed	650/1450/3150RPM		650/1450/3150RPM	
Spindle Thread	1-1/4" UNC & 1/2" G		1-1/4" UNC & 1/2" G	
1,2,3 Gear Drilling Diameter	202/102/52MM		202/102/52MM	
Compatible Stands	DSP-162& DSP-252		DSP-162& DSP-252	
Packing Size	635 x 215 x 460MM		635 x 215 x 460MM	



Brushless Drill Motor DMP-252B

Featured micro-percussion function accelerates dry drilling reinforced concrete work progress. Electronics for soft start and LED indicator for optimum drilling performance. Also, it's suitable for wet drilling when you need.

DMP-252B *new launch in 2024



DMP-252B

Brushless Drill Motor

 BRUSHLESS MOTOR

 WET OPERATION

 THREE SPEED

 LED INDICATOR LIGHT



Product Details



recommended core drill rig



HULK-252

HULK-252S

Specification

Model	DMP-252B	
Art No	1124252	
Power	3000W	2500W
Voltage	230V	120V
Current	16A	25A
N.W	6.8KG	
Frequency	50-60HZ	
Max. Drilling Diameter	252MM	
Speed	610/1320/2750RPM	
Spindle Thread	1-1/4" UNC	
1,2,3 Gear Drilling Diameter	252/132/76MM	
Compatible Stands	HULK-252&HULK-252S	
Packing Size	530 x 200 x 270MM	

Rig-Mounted Drill Motor

The robust rig-mounted drill motors are designed for handling tougher mid/heavy-duty tasks with high efficiency, meanwhile the whole series are equipped with smart LCD display for showing the real-time working conditions of the machine.



Smart LCD Display



DMP-252/352/500

recommended core drill rig



DMP-252&DSP-252



DMP-352&DSP-352



DMP-500&DSP-500

Specification

Model	DMP-252		DMP-352		DMP-500	
Art No.	1123252		1123352		1123500	
Input Power	2600W		3300W		3500W	
Voltage	230V	110V	230V	110V	230V	110V
Current	15A	25A	16A	25A	16A	25A
N.W	12.5KG	12.7KG	13.5KG	13.7KG	14KG	14.2KG
Frequency	50-60HZ		50-60HZ		50-60HZ	
Max Drilling Diameter	252MM		402MM		502MM	
No-Load Speed	560/1120/1680RPM		350/700/1100RPM		250/500/750RPM	
Spindle Thread	1-1/4UNC		1-1/4UNC		1-1/4UNC	
1,2,3 gear drilling diameter	252/102/80MM		402/202/102MM		502/302/162MM	
Stand for choice	DSP-252		DSP-352&DSP-2000		DSP-500&DSP-1500	
Packing size	635x460x215MM		635x460x215MM		635x460x215MM	

DUST EXTRACTION ADAPTER



SPECIFICATION

Use with a vacuum cleaner, the drill the drill connect to a vacuum cleaner for dry drilling, with a side connection for dust extraction.

- **NO. 3010010015**
- M18 female to 1-1/4" UNC male
- **NO. 3010010016**
- G1/2 female to 1-1/4" UNC male

SPECIFICATION

Used with a vacuum cleaner, the drill the drill connect to a vacuum cleaner for dry drilling, with a side connection for dust extraction.

- **NO. 3010010002**
- 1-1/4" UNC female to 1-1/4" UNC male
- **NO. 3010010003**
- M18 female to 1-1/4" UNC male
- **NO. 3010010005**
- M22 female to 1-1/4" UNC male
- **NO. 3010010006**
- M18 x 2.5 female to 1-1/4" UNC male
- **NO. 3010010007**
- M16 female to M16 male
- **NO. 3010010008**
- M18 x 2.5 female to M16 male
- **NO. 3010010009**
- M22 female to M16 male

SPECIFICATION

Used with a vacuum cleaner, the drill connects with dry electrician's drill for dust extraction. Side connection for vacuum cleaner, compatible with centering pin.

- **NO. 3010010004**
- M18 female to M16 male
- **NO. 3010010012**
- M22 female to M16 male
- **NO. 3010010013**
- M16 female to M16 male

SPECIFICATION

Used with a vacuum cleaner, the drill connects to a dry electrician's drill, with a built-in SDS Plus slot for easy bit changes.

- **NO. 4200010063**
- M18 female to M16 male



QUICK-RELEASE ADAPTER

Easy to change drill bit.

- **NO. 5190010175**
- 1-1/4" UNC female to 1-1/4" UNC male
- 1-1/4" UNC female to G1/2" male



DRILL BIT LIFTING HANDLE

Used with drill bits, making it easy to lift the drill bit.

- **NO. 3990010001**



CENTERING PIN

Positioning for electrician's drill usage.

- **NO. 3990020014**
- 107mm
- **NO. 4200010067**
- 117mm



WET DRILL ADAPTER

Used with DB-132 for wet drilling.

- **NO. 5110020019**
- M18 female to BSP 1/2 female



CORE BITS PULLER

Remove and replace the drill bit.

- **No. 3990020020**
- Thread : 1 1/4"-7 UNC



SDS DRILL BIT

- **NO. 3030250001**
- 8x150mm
- **NO. 3030250002**
- 8x160mm



SLURRY COLLECTING RING & SEALING PVC

Used in conjunction with a vacuum cleaner.

- **NO. 3040010001**
- Ø 100mm
- **NO. 3040010002**
- Ø 150mm



DRILL BIT LOCATOR

G1/2 connector, used for drill bit positioning.

- **NO. 4200010104**
- 300mm - 350mm - 400mm - 450mm



DEPTH GAUGE

- **NO. 5190010141**
- SW 6x250mm

Core Drill Rig



Drill Rig DSP Series

Easy operation, position precision and fastness which is suitable for most of brands' motors installation.

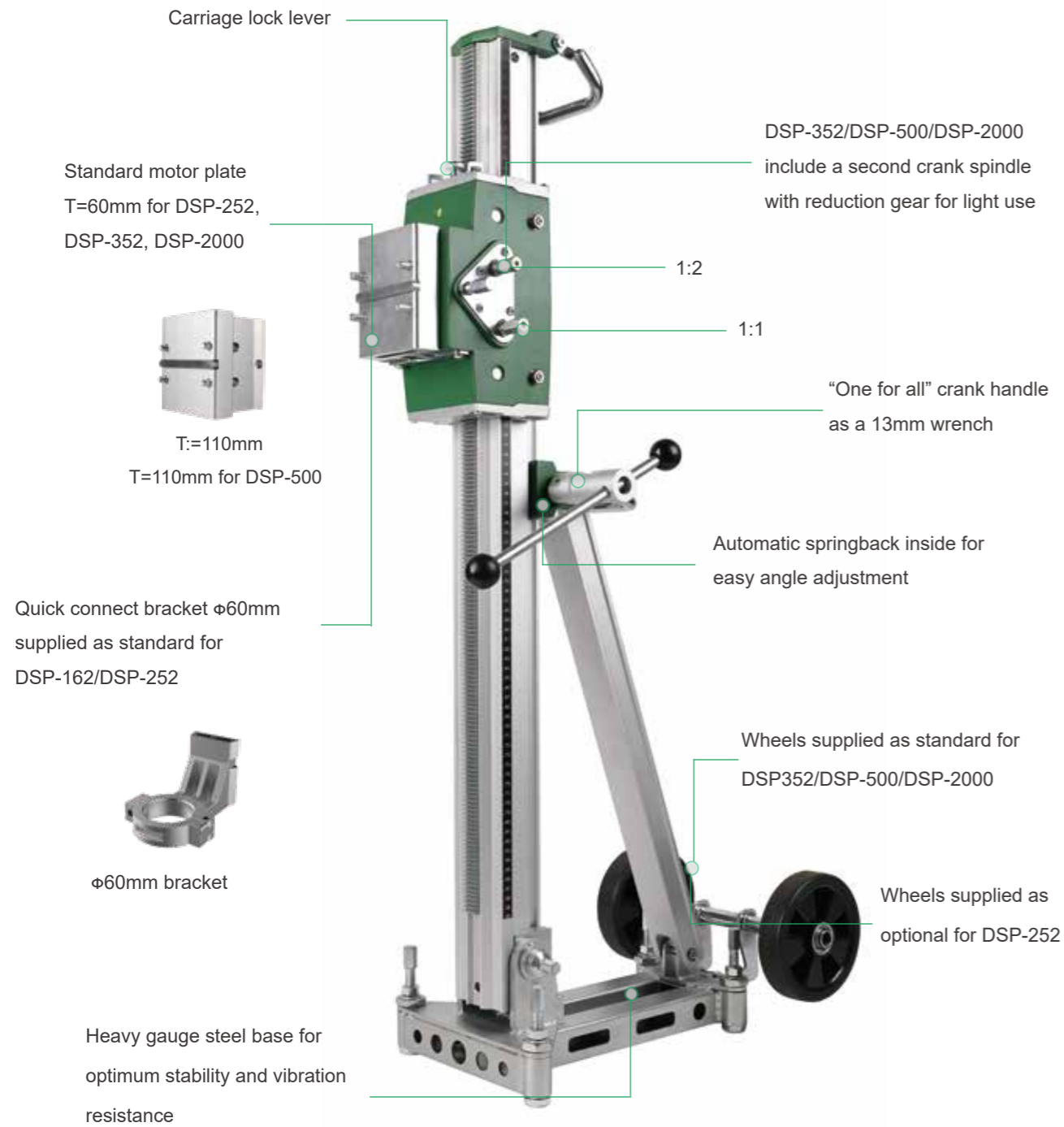

Model:	DSP-162	DSP-252	DSP-352	DSP-500	DSP-2000
Art No.	1070162	1070252	1070352	1070500	10702000
Max Drilling Diameter	202MM	252MM	402MM	502MM	352MM
Column	60x62x850MM	60x62x900MM	80x75x1000MM	80x75x1000MM	80x75x2000MM
Travel length	510MM	580MM	650MM	650MM	1600MM
Motor installing	φ60mm bracket	φ60mm bracket 60mm motor plate	60mm motor plate	110mm motor plate	60mm motor plate
N.W	11.5KG	13.5KG	18.5KG	19.5KG	25KG
Packing size	990x265x410MM	1045x230x45MM	1145x315x460MM	1145x315x460MM	2170x460x390MM
Wheels kits	Without wheels	Wheels kits optional	Standard	Standard	Standard

Drilling Solution Accessories

Bycon can supply a whole series products accessories for wet & dry drilling solution.



No.2410010
10L Pressurized water tank



No.2810010
Drill bit lifting handle



Anti-friction ring
No.4200010041



No.2410040
35L Water Tank with Electric Pump



Core bits puller
No.2410028



Extension rod 1-1/4UNC male to
1-1/4UNC female 150mm-550mm



No.2910100
Slurry Collecting Ring (100mm)



No.2910150
Slurry Collecting Ring (150mm)



Multiple rigs compatible with maximum
column length up to 2 meters



Vacumm pump(DVP-85)
No.106003



Vacumm plate
No.2210012



B+Drop-in Anchors set
No.3050020004



Anchor punch
No.5190010238

Ceiling Rig DSP-3000

This special rig is used for ceiling and horizontal vertical drilling.
The rig can be lift up and down range from 1.7 meters to 3 meters.



Good for
180 degrees adjusted



"One for all" crank handle



180° arbitrary adjustment



High strength rubber
360° universal wheel

Model	DSP-3000
Art No.	10703000
Max Ceiling Drilling	φ200MM
Outer Tube	50x50x1700MM
Inner Tube	40x40x1700MM
Max. Horizontal Drilling	φ200MM
Travel length	1700-3000MM
Mounting	60MM Motor plate & ø60 bracket
Packing size	2290x580x670MM

Drill rig HULK Series

- Eight steel wheels, more reliable positioning and more wear-resistant
- The rack lock teeth are highly rigid and more convenient to adjust
- Light weight, easier to transport

HULK-252

HULK-252S

*new launch in 2024

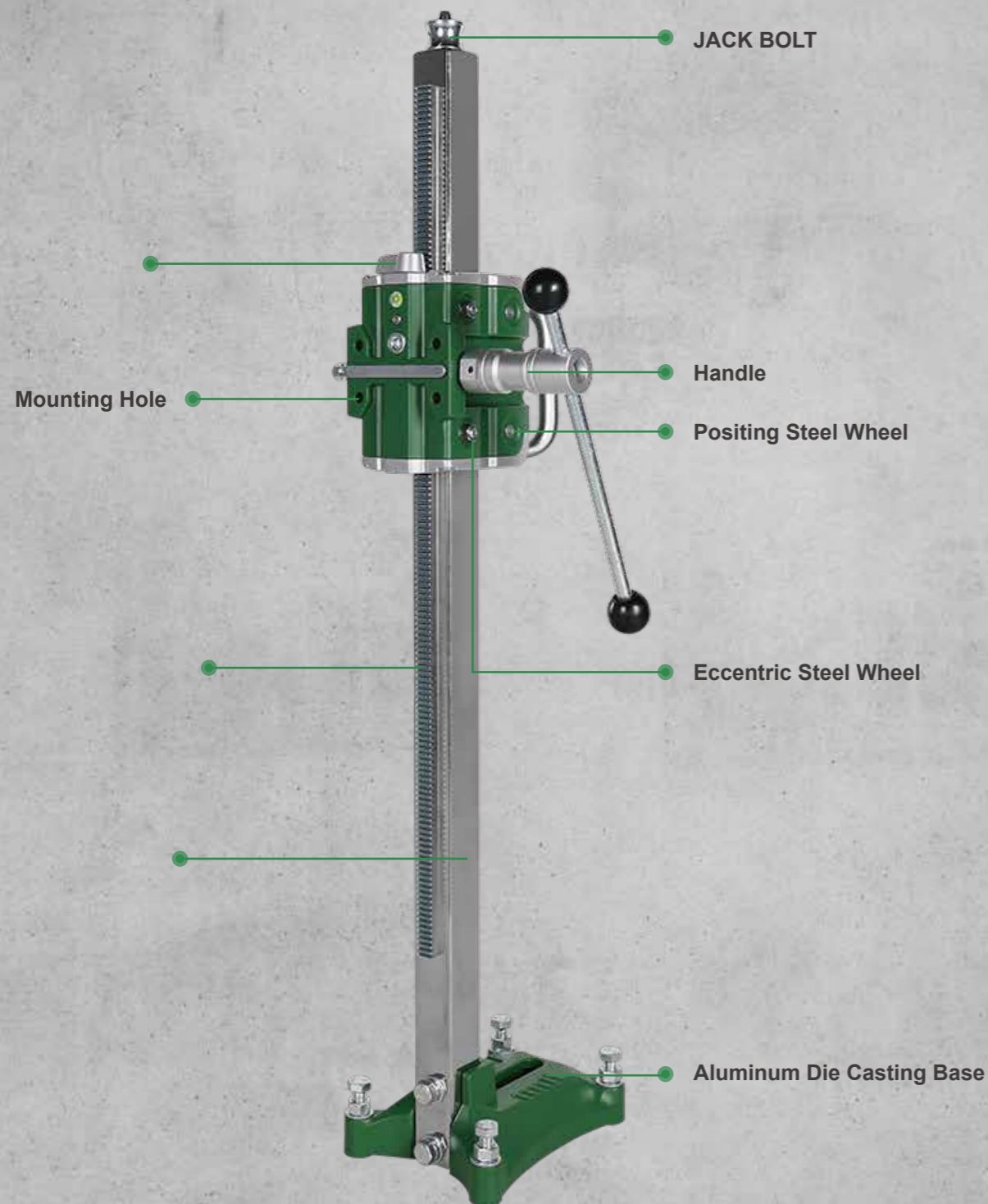

HULK-252/HULK-252S



HULK-252

HULK-252S

Product Details



Specification

Model	HULK-252	HULK-252S
Art No	1071252	1072252
Max. Drilling Diameter	252MM	252MM
Column	40 x 40 x 750MM	40 x 40 x 900MM
Travel Length	500MM	650MM
N.W	8.75KG	9.75KG
Packing Size	870 x 238 x 335MM	1020 x 238 x 335MM

Drill rig DBS Series

Versatile drill rigs with anti-vibration handle for micro percussion and common core drills.
Equipped with vacuum base suitable for vacuum sucker fixing or anchor fixing.

DBS-162

DBS-352

*new launch in 2024



DBS-162

DBS-352

Drill rig DBS-162



Product Details



Specification

Model	DBS-162
Art No	1071162
Max.Drilling Diameter	252MM
Column	40 x 40 x 850MM
Travel Length	580MM
N.W	16.75KG
Packing Size	1037.5 x 282 x 401MM

Drill rig DBS-352



Product Details



Specification

Model	DBS-352
Art No	1071352
Max. Drilling Diameter	352MM
Column	50 x 50 x 1000MM
Travel Length	670MM
N.W	23.45KG
Packing Size	1165 x 327 x 519MM



ANCHOR PUNCH

• NO. 5190010238



VACUUM PLATE

Used with a vacuum pump, quickly and securely adheres to various flat surfaces, ensuring that workpieces remain stable and immobile during drilling operations.

• NO.107001



VACUUM PUMP(DVP-75)

The vacuum pump, used in conjunction with the vacuum plate, ensures stability and reliability during operations.

• Power: 430 W • Weight: 14.3 KG • Air Flow: 113 L/MIN
• Max Pressure: -0.08 MPA • Speed: 1440 RPM/1720 RPM

• NO.106001



VACUUM PUMP(DVP-85)

The vacuum pump, used in conjunction with the vacuum plate, ensures stability and reliability during operations.

• Power: 430 W • Weight: 21.3 KG • Air Flow: 113 L/MIN
• Max Pressure: -0.09 MPA • Speed: 1440 RPM/1720 RPM

• NO.106003

**SETTING TOOLS (A)**

- **NO. 3050020001**
- M12×185mm
- **NO. 3050020015**
- M12×130mm

**SETTING TOOLS (B)**

- **NO. 3050020002**
- M12×185mm
- **NO. 3050020016**
- M12×250mm

**SETTING TOOLS (C)**

- **NO. 3050020006**
- 1/2"-13X6"

**SETTING TOOLS (D)**

- **NO. 3050020017**
- M12×185mm
- **NO. 3050020018**
- M12×130mm

**A+DROP-IN ANCHORS SET**

- **NO. 3050020009**
- M12×185mm
- **NO. 3050020013**
- M12×130mm

**B+DROP-IN ANCHORS SET**

- **NO. 3050020004**
- M12×185mm
- **NO. 3050020014**
- M12×250mm

**DROP-IN ANCHOR**

- **NO. 3050030001**

**ANCHOR ROD**

- **NO. 5099010008**
- M12×185
- M12×130
- M12×250
- 1/2-13UNC×215

**LIFT COLUMN**

Ceiling drill accessory. Range 1.7-3m

- **NO. 1090010001**
- 40mm outer tube, 30mm inner tube.
- **NO. 1090010002**
- 50mm outer tube, 40mm inner tube.

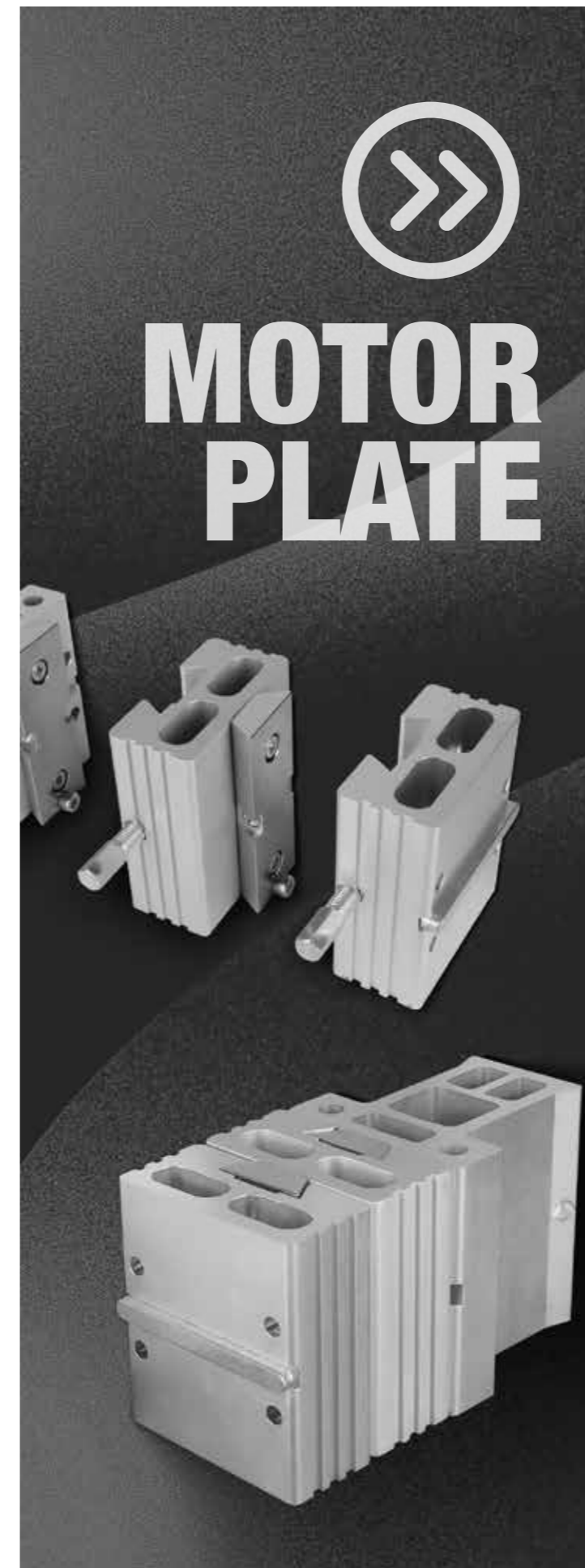
**60 MM MOTOR PLATE**

- ① **NO. 5020030002**
- w/o dovetail groove
- ② **NO. 5020030004**
- with dovetail groove

**110 MM MOTOR PLATE**

- ① **NO. 5020030005**
- w/o dovetail groove
- ② **NO. 5020030003**
- with dovetail groove

**50 MM SPACER**

- ① **NO. 5020030006**
- with key groove
- ② **NO. 5020030007**
- with dovetail groove

**DOVETAIL JOINT**

- **NO. 5190010105**

Floor Grinder

It can be used for stone renovation, floor leveling, concrete penetrant, hardener grinding treatment, polishing, also, it can be used for removing large area of old epoxy and old paint floor with modules.



DFG-250



DFG-300



DFG-480

DFG-250 series

Efficient grinding thanks to the high speed levels and the wide range of grinding discs available.



DFG-250E



Specification

Model	DFG-250E		DFG-250	
	Art No.	1211250	1211250U	1211250
Power	3HP	1.5HP	3HP	1.5HP
Motor	2.2KW	1.1KW	2.2KW	1.1KW
Voltage	220V	110V	220V	110V
Frequency	50HZ	60HZ	50HZ	60HZ
Speed	1410RPM	1730RPM	1410RPM	1730RPM
Current	12.7A	14.5A	12.7A	14.5A
Grinding diameter	250MM	250MM	250MM	250MM
N.W	62KG	53KG	58KG	48KG



Foldable design



angle adjustment



DFG-250E



DFG-250

DIAMOND TOOLS FOR FLOOR GRINDERS DFG-250 SERIES



Redi-Lock grinding shoes



250mm (10 Inch) PCD Grinding head



100mm (4 Inch) Polishing pad



250mm (10 Inch) Grinding head

STANDARD ACCESSORIES



Grinding head plate Redi-Lock shoes plate Countersunk screw

OPTIONAL ACCESSORIES



Multi-functional converter plate Grinding head Metoer grinding plate Grinding wheel 4" 100mm Velcro holder

DFG-250B *new launch in 2024

Efficient grinding thanks to the high speed levels and the wide range of grinding discs available.

45° angle adjustment



DFG-250B



① Round Rubber Shroud



② Edge Rubber Shroud

Specification

Model	DFG-250B	
Art No.	1213250	1213250U
Power	3HP	1.5HP
Motor	2.2KW	1.1KW
Voltage	220V	110V
Frequency	50HZ	60HZ
Speed	1410RPM	1730RPM
Current	12.7A	14.5A
Grinding diameter	250MM	250MM
N.W	62KG	53KG



Foldable Design



Angle Adjustment



Vacuum cleaner connection port



DFG-250B

DIAMOND TOOLS FOR FLOOR GRINDERS DFG-250 SERIES



Redi-Lock grinding shoes



250mm (10 Inch) PCD Grinding head



100mm (4 Inch) Polishing pad



250mm (10 Inch) Grinding head

STANDARD ACCESSORIES



Grinding head plate Redi-Lock shoes plate Countersunk screw

OPTIONAL ACCESSORIES



Multi-functional converter plate Grinding head Metal grinding plate Grinding wheel 4" 100mm Velcro holder

DFG-300 Series *new launch in 2024

300mm floor grinder allow you to quickly disassemble grinding head and frame for easily transport and storage. It's good for small to medium concrete area to remove paints, adhesive, epoxy and etc...



Specification

Model	DFG-300		DFG-300S		
Art No.	1221300		1222300		
Power	2.2KW/3HP	1.5KW/2HP	2.2KW/3HP		
Current	14A	18A	16A	8A	4.5A
Voltage	220V		110V	1PH 220V-240V	
Frequency	50HZ	60HZ	50HZ	60HZ	25-80HZ
Speed	1410RPM	1750RPM	1400RPM	1750RPM	700-2250RPM
Grinding diameter	300MM		300MM		
N.W	73.4KG		74KG		



Foldable Design



Angle Adjustment



Separable Frame and Motor



DFG-300

DFG-300S

DIAMOND TOOLS FOR FLOOR GRINDERS DFG-300 SERIES

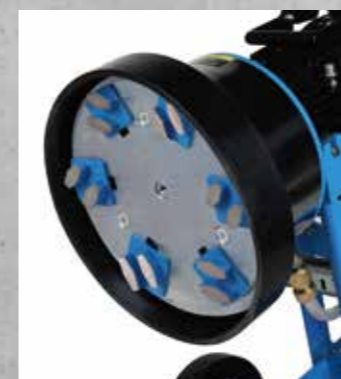

Redi-Lock grinding shoes



300mm (10 Inch)
PCD Grinding head



100mm (4 Inch) Polishing pad



300mm (10 Inch) Grinding head

STANDARD ACCESSORIES



Grinding head plate Redi-Lock shoes plate Countersunk screw

OPTIONAL ACCESSORIES



Multi-functional converter plate Grinding head Metal grinding plate Grinding wheel 4" 100mm Velcro holder

DFG-480 series

Efficient grinding thanks to the high speed levels and the wide range of grinding discs available.



DFG-480



DFG-480S

DIAMOND TOOLS FOR FLOOR GRINDERS DFG-480 SERIES



Redi-Lock grinding shoes



Grinding wheel



Grinding shoes



2" diamond plug *6 discs

Specification

Model	DFG-480	DFG-480U	DFG-480S
Art No.	1213480	1213480U	1214480
Power	3HP	2HP	4HP
Motor	2.2KW	1.5KW	3KW
Voltage	220V	110V	380V
Frequency	50HZ	60HZ	50-60HZ
Motor speed	2850RPM	2850RPM	2850RPM
Head speed	320RPM	380RPM	0-750RPM
Disc size	175(7")MM	175(7")MM	175(7")MM
Grinding diameter	480MM	480MM	480MM
Current	13.5A	18A	6.3A
Product rate	50-75m ² /H	50-75m ² /H	60-90m ² /H
N.W	160KG	160KG	163KG
Additional weight	2*11KG	2*11KG	2*11KG

STANDARD ACCESSORIES

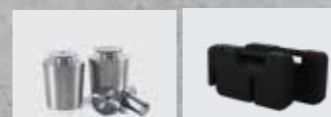

magnetic fitting plug additional weight

OPTIONAL ACCESSORIES

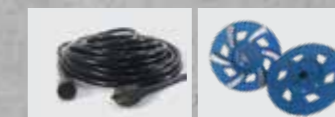

extension rod Grinding head

Floor Grinder Accessories

The single compact dust extractors is suitable for heavy dust jobs equipped with HEPA H13 filters compete the setup for maximum workplace safety



Adjustable handle



Please put two pieces weight block for better grinding during working.



DFG-480

Dust Collector



Please turn off the switch and press down the handle, when there is too much dust causes insufficient suction.



Please tie the bag tightly with the rope and cut it off. pulling the bag down and grabbed by the rope again for next vacuuming.

Dust Collector

- 1.OSHA compliant H13 HEPA filter.
- 2.“No marking type” rear wheels and lockable front caster.
- 3.Efficient jet pulse filter cleaning.
- 4.Smart and portable design, transporting is like a breeze.
- 5.Continuous bagging system ensures quick and dust-free bag changes.



IVC-1000

IVC-2000



Cyclone separator

IVC-3000

AVC-38HEPA

Specification

Model	IVC-1000		IVC-2000		Cyclone separator	IVC-3000		AVC-38HEPA	
Art No.	2311000		2312000		2310060	2313000		2320038	
Power	1.2KW		2.4KW			3.6KW		1.2KW	1.3KW
Voltage	220V	110V	220V	110V		240V	110V	220V	110V
Frequency	50HZ	60HZ	50HZ	60HZ		50	60HZ	50	60HZ
Current	4A		8A			14.4A		6A	9A
Airflow	200m ³ /H		400m ³ /H			600m ³ /H		220m ³ /H	
Vacuum	220mBar		220mBar			240mBar		238mBar	
Pre-filter	1.7m ² >99.5%@1.0um		3.0m ² >99.5%@1.0um			4.5m ² >99.5%@1.0um		/	
Hepa filter	1.2m ² >99.99%@0.3um		2.4m ² >99.99%@0.3um			3.6m ² >99.99%@0.3um		HEPA,>99.5%@0.3um	
Filter cleaning	Jet pulse filter cleaning		Jet pulse filter cleaning			Jet pulse filter cleaning		Jet pulse filter cleaning	
Dimension	420*680*1100MM		570*710*1270MM		450*450*870MM	630*840*1470MM		385*500*570MM	
Weight	30KG		48KG		16KG	65KG		29/13.5LBS/KG	
Collection	Continuous drop-down bag		Continuous drop-down bag			Continuous drop-down bag		/	

Floor saw



DFS-350



DFS-500

DFS-350

Light weight, easy carrying and storage. Adjustable handle and extendable right rear wheel for increased stability.



Operation board



Dust-free cutter holder



Height adjustment scale



Engine optional:

- Honda GX160
- Honda GX270
- Loncin 270



Model	DFS-350	DFS-350
Art No.	1502350H	1503350
Engine	Honda GX270	Loncin270
Power	9HP	9HP
Diamond blades. max.	350MM	350MM
Cutting Depth.max.	140MM	140MM
Water Tank	25L	25L
Net Weight	76KG	74KG

DFS-500

Both sides are available to install guard. Blades shaft mounting system reduce vibrations and give better cutting performance.



Operation board



High quality springs



Tools box



Model	DFS-500	DFS-500
Art No.	1511500H	1512500
Engine	Honda GX390	Loncin390
Power	9HP	9HP
Diamond blades. max.	500MM	500MM
Cutting Depth.max.	190MM	190MM
Water Tank	25L	25L
Net Weight	151KG	148KG



Shaft holder

Diamond core bits

Premium quality, laser-welded drill bits with fast drilling speed and long service life. A perfect match for Bycon core drilling motor.



Diamond core bits

Bycon diamond core bits are designed for fast drilling and maximum life with no damage on the wall, we have rich types diamond core bits which are used for drilling holes in hard and soft materials with or without steel reinforcing, such as cured and reinforced concrete, pre-stressed concrete, asphalt, brick, block, stone for air-conditioning, water pipe, gas nozzles, electric switches in walls and floors.



BYCON DIAMOND CORE BITS GENERAL VIEW

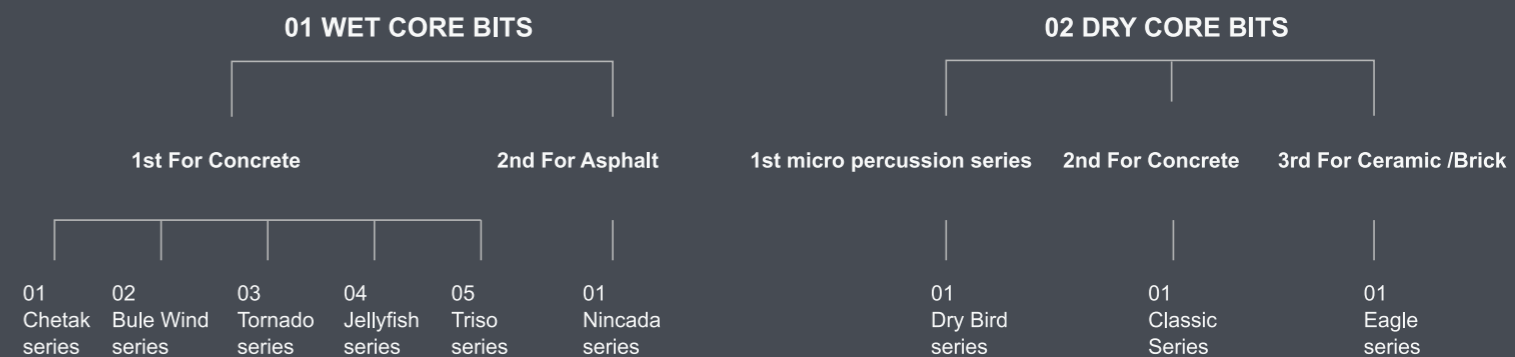

Different shape of segments are available, the most popular ones are:



Ring segment

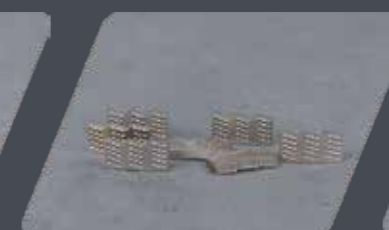

Shark segment

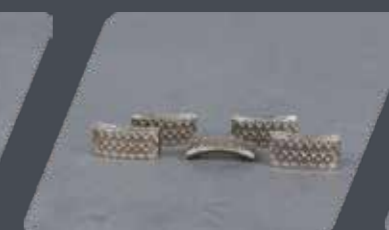

Grid segment



Rooftop segment

Wet core bits

Bycon wet core bits are specifically designed for use with our core drill for maximum versatility. Our concrete core drill bit sizes range from 42mm to 600mm to meet all your needs when drilling into concrete with rebar.



Reinforced concrete coring

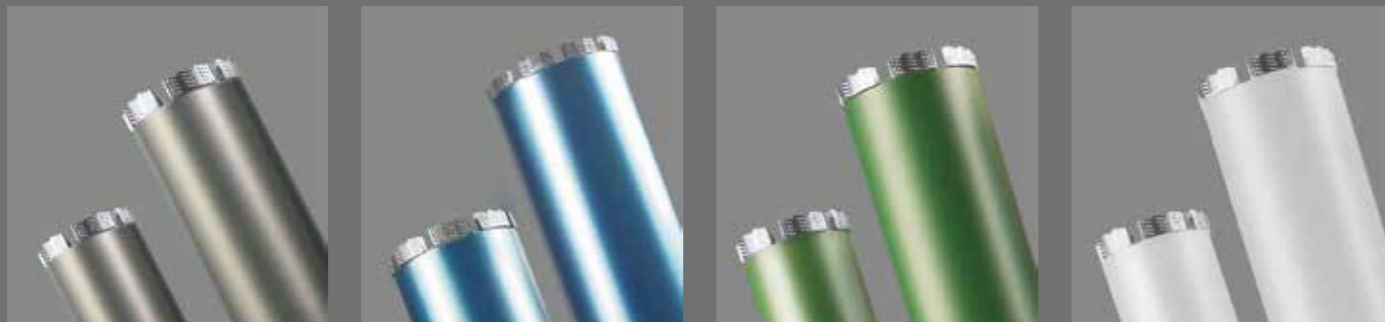

Chetak series

Blue wind series

Tornado series

Jellyfish series

01 Chetak series wins at high cost performance and it's an excellent integrated player in drilling reinforced concrete.

Chetak series

02 Blue wind series is ideal for low power handheld drill motor (1.5KW-2.6KW) drilling job at the fastest speed compare to others.

Blue Wind series

03 Tornado series is a perfect partner of rig-mounted drill motor up to 3.5kw, achieved higher speed without affecting life span.

Tornado series

04 It's the first choice for high frequency hydraulic equipment power more than 3.5kw both efficient and durable.

Jellyfish series

05 Nincada series is suitable for asphalt drilling job.

Nincada series



*Concrete/ Asphalt Wet Core Bits

Art number	O.D.(MM)	Working length (MM)	Thread	Barrel thickness (MM)	Segment size (MM)	Segment qty
2011042	42	450	1-1/4	2.0	20*3.5*10	4
2011047	47	450	1-1/4	2.0	24*3.5*10	5
2011052	52	450	1-1/4	2.0	24*3.5*10	5
2011057	57	450	1-1/4	2.0	24*3.5*10	5
2011062	62	450	1-1/4	2.0	24*3.5*10	6
2011067	67	450	1-1/4	2.0	24*3.5*10	6
2011072	72	450	1-1/4	2.0	24*3.5*10	7
2011077	77	450	1-1/4	2.0	24*3.5*10	7
2011082	82	450	1-1/4	2.0	24*3.5*10	8
2011087	87	450	1-1/4	2.0	24*3.5*10	8
2011092	92	450	1-1/4	2.0	24*3.5*10	8
2011102	102	450	1-1/4	2.0	24*3.5*10	9
2011107	107	450	1-1/4	2.0	24*3.5*10	9
2011112	112	450	1-1/4	2.0	24*3.5*10	10
2011117	117	450	1-1/4	2.0	24*3.5*10	10
2011122	122	450	1-1/4	2.0	24*3.5*10	10
2011127	127	450	1-1/4	2.0	24*3.5*10	10
2011132	132	450	1-1/4	2.0	24*3.5*10	11
2011142	142	450	1-1/4	2.0	24*3.5*10	11
2011152	152	450	1-1/4	2.0	24*4.0*10	12
2011162	162	450	1-1/4	2.0	24*4.0*10	12
2011172	172	450	1-1/4	2.0	24*4.0*10	13
2011182	182	450	1-1/4	2.0	24*4.0*10	13
2011192	192	450	1-1/4	2.0	24*4.0*10	14
2111202	202	450	1-1/4	2.0	24*4.0*10	15
2011220	220	450	1-1/4	2.0	24*4.0*10	16
2011250	250	450	1-1/4	2.0	24*4.0*10	17
2011280	280	450	1-1/4	2.0	24*4.0*10	19
2011300	300	450	1-1/4	3.0	24*4.5*10	21
2011350	350	450	1-1/4	3.0	24*4.5*10	23
3011400	400	450	1-1/4	3.0	24*4.5*10	25
2011450	450	450	1-1/4	3.0	24*4.5*10	27
2011500	500	450	1-1/4	3.0	24*5.0*10	29
2100600	600	450	1-1/4	3.0	24*5.0*10	31

Wet core bit with ring segment

Full crown, professional laser welded diamond core bits with high diamond concentration are suitable for handheld and rig-mounted applications. The crown segment provides better cutting comfort, resulting in better accuracy when start to drill.



Art number	O.D.(MM)	Working length (MM)	Thread	Barrel thickness (MM)	Segment size (MM)	Segment qty
2010010	10	450	1/2BSP/1-1/4	1.5	Ring*2.5*12	1
2010012	12	450	1/2BSP/1-1/4	1.5	Ring*2.5*12	1
2010014	14	450	1/2BSP/1-1/4	1.5	Ring*2.5*12	1
2010015	15	450	1/2BSP/1-1/4	1.5	Ring*2.5*12	1
2010016	16	450	1/2BSP/1-1/4	1.5	Ring*2.5*12	1
2010018	18	450	1/2BSP/1-1/4	1.5	Ring*2.5*12	1
2010020	20	450	1/2BSP/1-1/4	1.5	Ring*2.5*12	1
2010022	22	450	1/2BSP/1-1/4	1.5	Ring*2.5*12	1
2010024	24	450	1/2BSP/1-1/4	1.5	Ring*2.5*12	1
2010025	25	450	1/2BSP/1-1/4	1.5	Ring*2.5*12	1
2010026	26	450	1/2BSP/1-1/4	1.5	Ring*2.5*12	1
2010028	28	450	1/2BSP/1-1/4	1.5	Ring*2.5*12	1
2010030	30	450	1/2BSP/1-1/4	1.5	Ring*2.5*12	1
2010032	32	450	1/2BSP/1-1/4	1.5	Ring*2.5*12	1
2010033	33	450	1/2BSP/1-1/4	1.5	Ring*2.5*12	1
2010035	35	450	1/2BSP/1-1/4	1.5	Ring*2.5*12	1
2010038	38	450	1/2BSP/1-1/4	1.5	Ring*2.5*12	1
2010040	40	450	1/2BSP/1-1/4	1.5	Ring*2.5*12	1

Continuous core bit

Triso series

Working length of the core bit can be easily adjusted by increasing or decreasing the quantity of the tube part. A cost-wise choice for a worn-out continuous core bit only need a replacement on the drill head part.



Specification *Standard tube length: 250/300mm

Art number	O.D.(MM)	Drill head length (MM) (excl. segments)	Coupling length (MM)	Segment size (MM)	Segment qty
2012025	25	30	100	12*10*4.5	4
2012032	32	35	100	15*10*4.5	4
2012040	40	35	100	15*10*4.5	5
2012050	50	35	100	24*10*4.5	6
2012065	65	40	100	24*10*4.5	7
2012077	77	40	100	24*10*4.5	8
2012087	87	40	100	24*10*4.5	9
2012108	108	70	100	24*10*5.0	9
2012127	127	90	100	24*10*5.0	10
2012158	158	90	100	24*10*5.0	13
2012180	180	90	100	24*10*5.0	15
2012200	200	90	100	24*10*5.5	17
2012250	250	90	100	24*10*5.5	19
2012300	300	90	100	24*10*5.5	23

Wet core kits

This is a regular set, the internal size can be selected to match.



Specification

Art number	O.D.(MM)	Working length (MM)	Thread	Barrel thickness (MM)	Segment size (MM)	Segment qty
2014001	35	400/425/450	1/2 BSP	1.5	Ring*2.5*12	1
	51	400/425/450	1/2 BSP	1.5	24*2.5*10	5
	81	400/425/450	1/2 BSP	1.5	24*2.5*10	8
	132	400/425/450	1/2 BSP	1.5	24*2.5*10	11



Specification

Art number	O.D.(MM)	Working length (MM)	Thread	Barrel thickness (MM)	Segment size (MM)	Segment qty
2014002	35	400/425/450	1-1/4	1.5	Ring*2.5*12	1
	52	400/425/450	1-1/4	1.5	24*3.5*10	5
	82	400/425/450	1-1/4	1.5	24*3.5*10	8
	132	400/425/450	1-1/4	1.5	24*3.5*10	11

Pro micro-percussion dry core bits

Advanced dry core drill bit for micro-percussion drills range, the best solution for dry drilling in reinforced concrete, bricks and abrasive materials. Special diamond segment ensure a high performance with maximum cutting speed and high wear resistance over the life. It's wide applied in concrete wall for air conditioning installment, ventilation, heating installment or other communication lines without coolant.



Dry Bird C-01

The C-01 series of BYCON DRY BIRD micro percussion drill bits are for hand-held machines with rated power range from 1800 watts up to 3000 watts. Suitable for dry drilling through reinforced concrete, bricks and other building materials with high-efficiency.



Specification

Art number	Diameter(MM)	Segment size (MM)	Thread	Segment radius (MM)	Segment Qty
2120032	32	19*3.8*10	1 1/4UNC	R16	4
2120042	42	19*3.8*10	1 1/4UNC	R21	4
2120052	52	20*3.8*10	1 1/4UNC	R26	5
2120062	62	20*3.8*10	1 1/4UNC	R31-38	6
2120072	72	20*3.8*10	1 1/4UNC	R31-38	7
2120076	76	20*3.8*10	1 1/4UNC	R31-38	7
2120082	82	20*3.8*10	1 1/4UNC	R41-46	8
2120092	92	20*3.8*10	1 1/4UNC	R41-46	8
2120102	102	20*3.8*10	1 1/4UNC	R51-66	8
2120112	112	20*3.8*10	1 1/4UNC	R51-66	9
2120122	122	20*3.8*10	1 1/4UNC	R51-66	9
2120127	127	20*3.8*10	1 1/4UNC	R51-66	9
2120132	132	20*3.8*10	1 1/4UNC	R51-66	10

Micro percussion segment

Suitable for welding on $\Phi 32$ mm to $\Phi 300$ mm dry core bits and socket drill bits as well.



Specification

Art number	Diameter(MM)	Segment size (MM)	Thread	Segment radius (MM)	Segment Qty
2121042	42	19*3.8*10	1 1/4UNC	R21	5
2121052	52	20*3.8*10	1 1/4UNC	R26	6
2121062	62	20*3.8*10	1 1/4UNC	R31-38	7
2121072	72	20*3.8*10	1 1/4UNC	R31-38	8
2121076	76	20*3.8*10	1 1/4UNC	R31-38	8
2121082	82	20*3.8*10	1 1/4UNC	R41-46	9
2121092	92	20*3.8*10	1 1/4UNC	R41-46	9
2121102	102	20*3.8*10	1 1/4UNC	R51-71	10
2121112	112	20*3.8*10	1 1/4UNC	R51-71	10
2121122	122	20*3.8*10	1 1/4UNC	R51-71	11
2121127	127	20*3.8*10	1 1/4UNC	R51-71	11
2121132	132	20*3.8*10	1 1/4UNC	R51-71	12
2121142	142	20*3.8*10	1 1/4UNC	R51-71	13
2121152	152	20*4.3*10	1 1/4UNC	R76-86	14
2121162	162	20*4.3*10	1 1/4UNC	R76-86	15
2121172	172	20*4.3*10	1 1/4UNC	R76-86	16
2121182	182	20*4.3*10	1 1/4UNC	R91-113	17
2121202	202	20*4.3*10	1 1/4UNC	R91-113	18
2121225	225	20*4.3*10	1 1/4UNC	R91-113	19
2121250	250	20*4.5*10	1 1/4UNC	R125-150	20
2121270	270	20*4.5*10	1 1/4UNC	R125-150	21
2121300	300	20*4.5*10	1 1/4UNC	R125-150	22

Application

Ideal for reinforced concrete, gas and foam concrete, bricks and blocks

Dry Bird C-02

The C-02 series of BYCON DRY BIRD micro-percussion drill bits are compatible with more powerful rig-mounted machines, rated power from 3000 watts and above.

C-02 Features with robust drilling through reinforced concrete with multiple layers of rebars

Micro-percussion socket drill bits

We recommend using them on micro percussive dry core drills with 1200 watts motor or above while motor speed ranges from 1500 to 3000 RPM. (not a hammer drill)



Specification



Art number	Diameter(MM)	Segment size (MM)	Thread	Segment radius (MM)	Number of segments
2123068	68	20*3.8*10	M16	R31-38	5
2123072	72	20*3.8*10	M16	R31-38	5
2123082	82	20*3.8*10	M16	R41-46	6

Specification

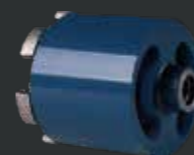

Art number	Diameter(MM)	Segment size (MM)	Thread	Segment radius (MM)	Number of segments
2124068	68	20*3.8*10	M16	R31-38	5
2124072	72	20*3.8*10	M16	R31-38	5
2124082	82	20*3.8*10	M16	R41-46	6

Tested in BYCON working site

Dry drilling with micro-percussion mode machines, reduce your cost and boost efficiency.

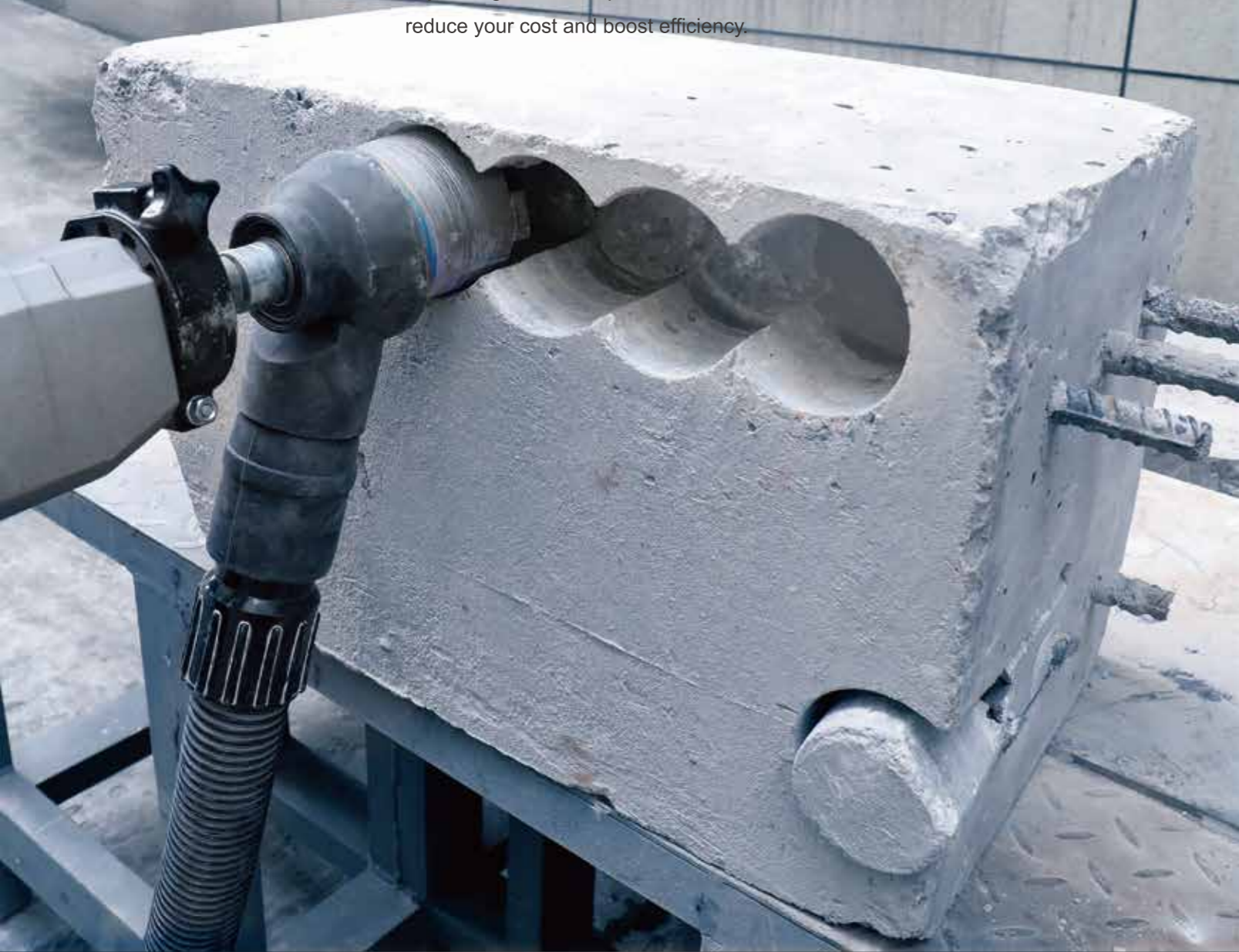

Application

Perfect for installing socket outlets for plug sockets and junction boxes.

Ideally suited for drilling on all types of masonry as well as reinforced concrete.

Dry core bit

Socket drill bit is especially suitable for professional installing of plug outlets and junction boxes. With laser-welded turbo segments (other segment shapes are available as well), it is designed to dry core drill on sand lime brick as well as all types of masonry. Additional slots on the drill barrel are for dust extraction purpose.



Eagle series

Profession dry core bit for electric outlet sockets and other applications. Additional accessories including drift key, pilot drill, SDS plus shank or magnetic center drill kit.



Specification

Art number	O.D.(MM)	Working length (MM)	Thread	Barrel thickness (MM)	Segment size (MM)	Segment qty
2023068	68	60	M16	2.0	24*3.8*10	4
2023072	72	60	M16	2.0	24*3.8*10	4
2023076	76	60	M16	2.0	24*3.8*10	4
2023082	82	60	M16	2.0	24*3.8*10	5

Classic series

Classic series dry core bits are designed to be used on concrete and masonry. They are engineered with widely spaced turbo style diamond segments that allow for fast drilling and aid in heat dissipation.



Specification

Art number	O.D.(MM)	Working length (MM)	Thread	Barrel thickness (MM)	Segment size (MM)	Segment qty
2022025	25	150	1/2 BSP/ M16	2.0	15*3.8*10	2
2022032	32	150	1/2 BSP/ M16	2.0	15*3.8*10	3
2022038	38	150	1/2 BSP/ M16	2.0	15*3.8*10	4
2022048	48	150	1/2 BSP/ M16	2.0	24*3.8*10	4
2022052	52	150	1/2 BSP/ M16	2.0	24*3.8*10	4
2022065	65	150	1/2 BSP/ M16	2.0	24*3.8*10	4
2022078	78	150	1/2 BSP/ M16	2.0	24*3.8*10	4
2022091	91	150	1/2 BSP/ M16	2.0	24*3.8*10	4
2022102	102	150	1/2 BSP/ M16	2.0	24*3.8*10	5
2022107	107	150	1/2 BSP/ M16	2.0	24*3.8*10	5
2022117	117	150	1/2 BSP/ M16	2.0	24*3.8*10	5
2022127	127	150	1/2 BSP/ M16	2.0	24*3.8*10	6
2022142	142	150	1/2 BSP/ M16	2.0	24*3.8*10	7
2022152	152	150	1/2 BSP/ M16	2.0	24*3.8*10	7
2022162	162	150	1/2 BSP/ M16	2.0	24*3.8*10	8
2022172	172	150	1/2 BSP/ M16	2.0	24*3.8*10	8
2022182	182	150	1/2 BSP/ M16	2.0	24*3.8*10	9

Dry core kits

Electrician core bits kit with 5 most used sizes of socket drill bit supplied with an aluminum carry case.

Adaptors, pilot drill and other accessories are included in the kit as well, complete and convenient for professional electrician use.



Accessories

- Drift key
- HEX- 1/2 BSP adapter
- SDS- 1/2 BSP adapter
- Extension bar 1/2 BSP
- SDA MAX- 1/2 BSP adapter
- Pilot drill
- Guide bar

Specification

- 8*70MM
- L=88MM
- L=115mm
- F-M 250MM
- L=180MM
- 13*210MM
- 12*210MM



Specification

Art number	O.D.(MM)	Working length (MM)	Thread	Barrel thickness (MM)	Segment size (MM)	Segment qty
2021100	38	150	1/2 BSP	2.0	15*3.8*10	4
	52	150	1/2 BSP	2.0	24*3.8*10	4
	65	150	1/2 BSP	2.0	24*3.8*10	4
	117	150	1/2 BSP	2.0	24*3.8*10	5
	127	150	1/2 BSP	2.0	24*3.8*10	5

Specification



Description	Art number	Length (MM)
SDS plus to 1/2BSP (M16/5/8-11") for taper drill	2610002	100
SDS plus to 1/2BSP (M16/5/8-11") for taper drill	2610004	115
SDS plus to 1/2BSP (M16/5/8-11") for taper drill	2610006	120
SDS plus to 1/2BSP (M16/5/8-11") for taper drill	2610008	200
SDS plus to 1/2BSP (M16/5/8-11") for taper drill	2610010	240
SDS plus to 1/2BSP (M16/5/8-11") for taper drill	2610012	300
SDS plus to 1/2BSP (M16/5/8-11") for taper drill	2610014	400
HEX to1/2BSP (M16/M22/5/8-11") for taper drill	2610102	88
HEX to1/2BSP (M16/M22/5/8-11") for taper drill	2610104	100
HEX to1/2BSP (M16/M22/5/8-11") for taper drill	2610106	115
HEX to1/2BSP (M16/M22/5/8-11") for taper drill	2610108	120
HEX to1/2BSP (M16/M22/5/8-11") for taper drill	2610110	200
HEX to1/2BSP (M16/M22/5/8-11") for taper drill	2610112	240
HEX to1/2BSP (M16/M22/5/8-11") for taper drill	2610114	300
HEX to1/2BSP (M16/M22/5/8-11") for taper drill	2610116	400
SDS Max to 1 1/4UNC	2610202	200
SDS Max to 1 1/4UNC	2610204	240
SDS Max to 1 1/4UNC	2610206	300
SDS Max to 1 1/4UNC	2610208	400
SDS Max to 1 1/4UNC	2610210	500
SDS Max to1/2BSP (M16/5/8-11") for taper drill	2610302	200
SDS Max to1/2BSP (M16/5/8-11") for taper drill	2610304	240
SDS Max to1/2BSP (M16/5/8-11") for taper drill	2610306	300
SDS Max to1/2BSP (M16/5/8-11") for taper drill	2610308	400
SDS plus to M22 for taper drill	2610402	100
SDS plus to M22 for taper drill	2610404	115
SDS plus to M22 for taper drill	2610406	120
SDS plus to M22 for taper drill	2610408	200
SDS plus to M22 for taper drill	2610410	240
SDS plus to M22 for taper drill	2610412	300
SDS plus to M22 for taper drill	2610414	400
SDS plus to M16/1/2BSP/5/8-11" for Straight shank drill	2610502	100
SDS plus to M16/1/2BSP/5/8-11" for Straight shank drill	2610504	120
SDS plus to M16/1/2BSP/5/8-11" for Straight shank drill	2610506	200
SDS plus to M16/1/2BSP/5/8-11" for Straight shank drill	2610508	240
SDS plus to M16/1/2BSP/5/8-11" for Straight shank drill	2610510	300
SDS plus to M16/1/2BSP/5/8-11" for Straight shank drill	2610512	400

Specification



Description	Art number	Length (MM)
HEX to M16/1/2BSP/5/8-11" for Straight shank drill	2610601	88
SDS plus to 1/2BSP (M16/5/8-11") for taper drill	2610602	100
SDS plus to 1/2BSP (M16/5/8-11") for taper drill	2610604	120
SDS plus to 1/2BSP (M16/5/8-11") for taper drill	2610606	200
SDS plus to 1/2BSP (M16/5/8-11") for taper drill	2610608	240
SDS plus to 1/2BSP (M16/5/8-11") for taper drill	2610610	300
SDS plus to 1/2BSP (M16/5/8-11") for taper drill	2610612	400
SDS Plus to 1/2" BSP Female	2611002	100
SDS Max to 1/2" BSP Female	2612002	200
Hex Adaptor to 1/2" BSP Female	2613002	100
SDS Max to 1/2" BSP(M16,M22,5/8-11") Male	2614002	120
3 Sided 3/8" SHANK TO 5/8-11 Male	2615002	70
Drift key	2616002	8*70
A Taper Guide Rod 210mm	2617002	210
Straight shank drill	2618000	8*120
A Taper drill	2618001	8*120
A Taper drill	2618002	10x200
A Taper drill	2618003	10x210
A Taper drill	2618004	10x300
A Taper drill	2618006	10x450
A Taper drill	2618008	13x230
3pcs drill bit adaptor for dry core bits	2619002	Taper drill 6.5x120
3pcs drill bit adaptor for dry core bits	2619004	SDS plus +M16 *100
3pcs drill bit adaptor for dry core bits	2619006	Drift key

Specification



Description	Art number	Length (MM)
1 1/4UNC male to 1 1/4UNC female round shank	2620002	150
1 1/4UNC male to 1 1/4UNC female round shank	2620004	200
1 1/4UNC male to 1 1/4UNC female round shank	2620006	250
1 1/4UNC male to 1 1/4UNC female round shank	2620008	300
1 1/4UNC male to 1 1/4UNC female round shank	2620010	350
1 1/4UNC male to 1 1/4UNC female round shank	2620012	400
1 1/4UNC male to 1 1/4UNC female round shank	2620014	450
1 1/4UNC male to 1 1/4UNC female round shank	2620016	500
1 1/4UNC male to 1 1/4UNC female round shank	2620018	550
1 1/4UNC male to 1 1/4UNC female hexagonal shank	2621002	150
1 1/4UNC male to 1 1/4UNC female hexagonal shank	2621004	200
1 1/4UNC male to 1 1/4UNC female hexagonal shank	2621006	250
1 1/4UNC male to 1 1/4UNC female hexagonal shank	2621008	300
1 1/4UNC male to 1 1/4UNC female hexagonal shank	2621010	350
1 1/4UNC male to 1 1/4UNC female hexagonal shank	2621012	400
1 1/4UNC male to 1 1/4UNC female hexagonal shank	2621014	450
1 1/4UNC male to 1 1/4UNC female hexagonal shank	2621016	500
1 1/4UNC male to 1 1/4UNC female hexagonal shank	2621018	550
1/2BSP (M16/5/8-11") male to 1/2BSP (M16/5/8-11") female	2622002	150
1/2BSP (M16/5/8-11") male to 1/2BSP (M16/5/8-11") female	2622004	200
1/2BSP (M16/5/8-11") male to 1/2BSP (M16/5/8-11") female	2622006	250
1/2BSP (M16/5/8-11") male to 1/2BSP (M16/5/8-11") female	2622008	300
1/2BSP (M16/5/8-11") male to 1/2BSP (M16/5/8-11") female	2622010	350
1/2BSP (M16/5/8-11") male to 1/2BSP (M16/5/8-11") female	2622012	400
1/2BSP (M16/5/8-11") male to 1/2BSP (M16/5/8-11") female	2622014	450
1/2BSP (M16/5/8-11") male to 1/2BSP (M16/5/8-11") female	2622016	500
1/2BSP (M16/5/8-11") male to 1/2BSP (M16/5/8-11") female	2622018	550
1/2BSP female to 1 1/4UNC female	2623002-Hex	100
1/2BSP female to 1 1/4UNC female	2624002-Round	100

Specification



Description	Art number	Length (MM)
1 1/4UNC female to 1/2BSP (M16/ 1/2BSP) male	2625002	100
1 1/4UNC female to 1/2BSP (M16/ 1/2BSP) male	2625004	120
1 1/4UNC male to M22	2626002	90-100
1 1/4UNC male to 1/2BSP male	2627002-Hex	105
1 1/4UNC male to 1/2BSP male	2627004-Round	100
1/2BSP male to 1/2BSP (5/8-11/ M16) male	2628002	
1/2BSP (5/8-11/ M16) female to 1/2BSP (5/8-11/ M16) female	2629002	
BL to 1 1/4UNC M & 1/2 BSP F	2610028	
BI to 1 1/4UNC M & 1/2 BSP F	2610030	
BI to 1/2 BSP F	2610032	
BI to PIXIE M & 1/2 BSP F	2610034	
"6 slot to 1 1/4UNC M & 1/2 BSP F"	2610036	
6 slot to PIXIE M & 1/2 BSP F	2610038	
Spline to 1 1/4UNC M	2610040	
BL to M41	2610042	
BI to 1/2 BSP M	2610044	

Diamond Blades Information

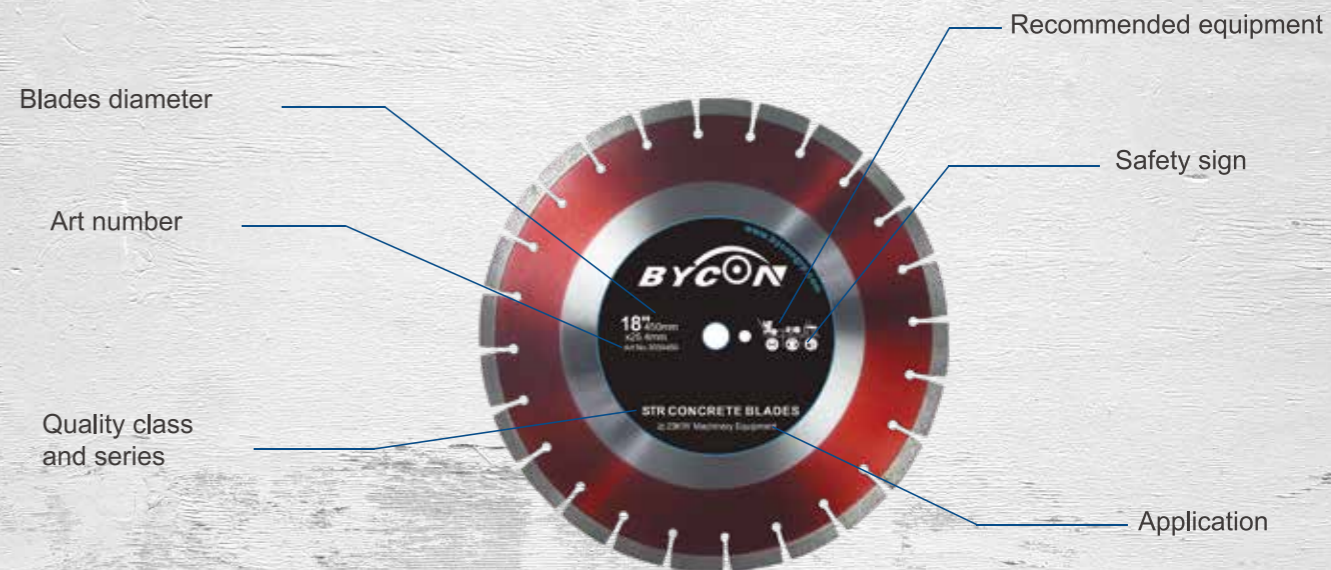

Diamond blades

Products

	ECO Universal	PRO Universal	Concrete	Asphalt	Superfine prealloy	Wall saw	All cutting	Tile cutting	STR Concrete
Material									
Ceramic tiles							★	★★	
Natural stone	★	★★			★★★		★	★	
Cured Concrete	★	★★	★★		★★★		★		★★
Reinforce concrete		★★	★★		★★★	★★★	★		★★
Green concrete			★	★			★		★★
Asphalt			★	★★			★		★★
Abrasive Material				★			★		
Brick	★	★			★		★		
Roof tiles	★	★			★		★	★	
Metal	★	★★			★★★		★		
Ductile iron	★	★★			★★★		★		

*Optimal ★★★

*Good ★★

*Acceptable ★

Diamond blades

Bycon diamond blades are designed for fast cutting speed, long service life and better cutting performance when cutting reinforced concrete, asphalt, tile, brick and other minerals.





ECO Universal diamond blades

Art number	Diameter (MM)	segment (MM)	Teeth (T)	Thickness of body (MM)	Arbor hole (MM)	Rabbit
3000115	115	2.2*10*30	8	1.4	22.23	Key
3000125	125	2.2*10*30	9	1.4	22.23	Key
3000230	230	2.4*10*38	16	1.8	22.23	Key
3000300	300	3.0*10*40	20	2.2	25.4	Key
3000350	350	3.2*10*40	24	2.2	25.4	Key
3000400	400	3.4*10*40	28	2.4	25.4	Key
3000450	450	3.6*10*40	32	2.8	25.4	Key
3000500	500	3.8*10*40	36	3.0	25.4	Key
3000600	600	4.4*10*40	42	3.5	25.4	Key



PRO Universal diamond blades

Art number	Diameter (MM)	segment (MM)	Teeth (T)	Thickness of body (MM)	Arbor hole (MM)	Rabbit
3035125	125	2.2*10*30	10	1.2	22.2	Key
3035150	150	2.4*10*30	9	1.6	22.2	Key
3035180	180	2.4*10*38	11	1.6	22.2	Key
3035230	230	2.6*10*40	16	2.0	22.2	Key
3035300	300	3.0*10*40	20	2.0	20/25.4/30	Key
3035350	350	3.2*10*40	24	2.2	20/25.4/30	Key
3035400	400	3.4*10*40	28	2.4	20/25.4/30	Key
3035450	450	3.6*10*40	32	2.8	20/25.4/30	Key
3035500	500	3.8*10*40	36	3.2	20/25.4/30	Key

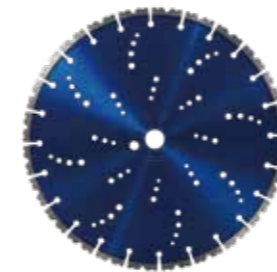

Concrete diamond blades

Art number	Diameter (MM)	segment (MM)	Teeth (T)	Thickness of body (MM)	Arbor hole (MM)	Rabbit
3027300	300	3.0*10*40	24	2.2	25.4	Key
3027350	350	3.2*10*40	24	2.2	25.4	Key
3027400	400	3.4*10*40	28	2.4	25.4	Key
3027450	450	3.6*10*40	32	2.8	25.4	Key
3027500	500	3.8*10*40	36	3.0	25.4	Key
3027600	600	4.5*12*40	42	3.5	60/25.4	Key
3027650	650	4.5*12*40	44	3.5	60/25.4	Key
3027700	700	4.5*12*40	48	3.5	60/25.4	Key
3027800	800	5.0*12*40	56	3.5	60/25.4	Key
3027900	900	5.0*12*40	62	3.5	60/25.4	Key
3071000	1000	5.0*12*40	68	3.5	60/25.4	Key
3071200	1200	5.0*12*40	80	3.5	60/25.4	Key



Asphalt diamond blades

Art number	Diameter (MM)	segment (MM)	Teeth (T)	Thickness of body (MM)	Arbor hole (MM)	Rabbit
3024300	300	3.0*10*40	18	2.2	25.4/20	Wide U
3024350	350	3.2*10*40	21	2.2	25.4/20	Wide U
3024400	400	3.4*10*40	24	2.4	25.4/20	Wide U
3024450	450	3.6*10*40	26	2.8	25.4/20	Wide U
3024500	500	3.8*10*40	30	3.0	25.4/20	Wide U



3024600	600	4.5*12*40	36	3.5	25.4/20	Wide U
3024650	650	4.5*12*40	40	3.5	25.4/20	Wide U
3024700	700	4.5*12*40	44	3.5	25.4/20	Wide U
3024800	800	5.0*12*40	50	3.5	25.4/20	Wide U
3024900	900	5.0*12*40	56	3.5	25.4/20	Wide U
3021000	1000	5.0*12*40	62	3.5	25.4/20	Wide U
3021200	1200	5.0*12*40	74	3.5	25.4/20	Wide U

Superfine prealloy diamond blades

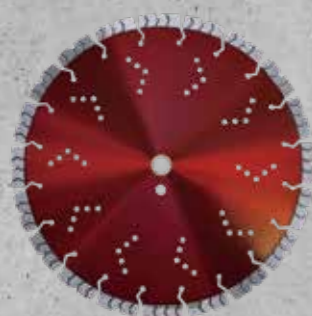

Art number	Diameter (MM)	segment (MM)	Teeth (T)	Thickness of body (MM)	Arbor hole (MM)	Rabbit
3037115	115	2.3*12* 32	8	1.4	25.4	Arrow teeth
3037125	125	2.3*12* 32	9	1.4	25.4	Arrow teeth
3037150	150	2.6*12* 40	9	1.6	25.4	Arrow teeth
3037180	180	2.6*12* 42	11	1.6	25.4	Arrow teeth
3037230	230	2.6*15* 42	14	1.8	25.4	Arrow teeth
3037300	300	3.0*15* 46	18	2.2	25.4	Arrow teeth
3037350	350	3.2*15* 47	20	2.4	25.4	Arrow teeth
3037400	400	3.5*15* 46	24	2.6	25.4	Arrow teeth
3037450	450	4.0*15* 46	27	2.8	25.4	Arrow teeth
3037500	500	4.0*15* 46	30	3.0	25.4	Arrow teeth

Wall saw diamond blades



Art number	Diameter (MM)	segment (MM)	Teeth (T)	Thickness of body (MM)	Arbor hole (MM)	Rabbit
3021600	600	4.5*12*40	36	3.5	60	Wide U
3021650	650	4.5*12*40	38	3.5	60	Wide U
3021700	700	4.5*12*40	40	3.5	60	Wide U
3021750	750	4.5*12*40	44	3.5	60	Wide U
3021800	800	4.5*12*40	46	3.5	60	Wide U
3021900	900	4.5*12*40	48	3.5	60	Wide U
3041000	1000	4.5*12*40	50	3.5	60	Wide U
3041200	1200	4.5*12*40	60	3.5	60	Wide U
3041400	1400	4.5*12*40	70	3.5	60	Wide U
3041600	1600	4.5*12*40	80	3.5	60	Wide U

All cutting diamond blades



Art number	Diameter (MM)	segment (MM)	Thickness of body (MM)	Arbor hole (MM)
3036115	115	2.2*10	1.2	22.23/20
3036125	125	2.2*10	1.2	22.23/20
3036150	150	2.4*10	1.4	22.23/20
3036180	180	2.6*10	1.6	22.23/20
3036230	230	2.8*10	1.8	22.23/20
3036250	250	3.0*10	2.0	22.23/20
3036300	300	3.2*10	2.2	25.4/22.23
3036350	350	3.2*10	2.2	25.4/22.23

Tile cutting diamond blades



Art number	Diameter (MM)	segment (MM)	Thickness of body (MM)	Arbor hole (MM)
3025105	105	1.2*10	0.8	22.23
3025115	115	1.2*10	0.8	22.23
3025125	125	1.2*10	0.8	22.23
3035150	150	1.2*10	0.8	22.23
3035180	180	1.2*10	0.8	22.23
3035230	230	1.6*10	1.2	22.23
3035300	300	1.6*10	1.2	25.4/22.23
3035350	350	1.8*10	1.4	25.4/22.23
3035400	400	1.8*10	1.4	25.4/22.23
3035450	450	2.0*10	1.6	25.4
3035500	500	2.0*10	1.6	25.4

STR Concrete diamond blades



Art number	Diameter (MM)	segment (MM)	Teeth (T)	Thickness of body (MM)	Arbor hole (MM)	Rabbit
3038400	400	3.4*15* 40	28	2.4	25.4	Key
3038450	450	3.6*15* 40	30	2.6	25.4	Key
3038500	500	3.8*15* 40	34	3.0	25.4	Key
3038600	600	4.5*15* 40	40	3.5	25.4	Key
3038700	700	4.5*15* 40	46	3.5	25.4	Key
3038800	800	5.0*15* 40	54	4.0	25.4	Key

Diamond wire

BWS/BWP

This is construction diamond wire, sharp and durable, with sintered beads are widely used in construction demolition, metro and bridge, etc.



Specification

Model	BWS	BWP
Art No	4020010	4020020
Application	Reinforced concrete	Highly reinforced concrete
Type	Sintered	Sintered
Fixed mode	Spring+Rubber	Spring+Rubber
Beads(pcs/m)	40	40
Beads dia.(mm)	11.5	11.5
Net weight(kg/roll)	20	20
Package size(mm)	300x300x250	300x300x250
Recommended equipment	22KW-30KW hydraulic diamond wire machine , 15kw electric diamond wire machine	≥30KW hydraulic diamond wire machine, 15kw electric diamond wire machine

Application

The construction diamond wire with sintered beads are designed for cutting highly reinforced concrete, reinforced concrete and concrete;

Recommended for wet use. Comparing with the traditional processing, its advantages are more economic, high efficiency of cutting, saving energy and more environmental protection;



BWS/BWP SERIES



Sintered beads



Straight connector



Rubber



Spring

Installation

According to determined cutting mode, wind the wire saw, in the driving wheel and supporting wheel in a certain order.

*Attention: the rope and the driving wheels must be in the same direction.

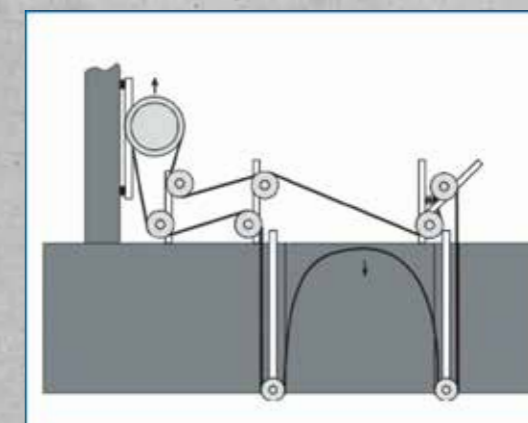

Grinding tools

Grinding is used to remove high spots and imperfection on the concrete surface. Bycon offer different diamond grinding tools for sale with diversity sizes and design of segment.

They are designed to be used for dry or wet grinding of concrete and other masonry materials to smooth uneven surfaces and remove flashing. The diamond matrix provides the life of conventional abrasives and allows for more aggressive material removal.

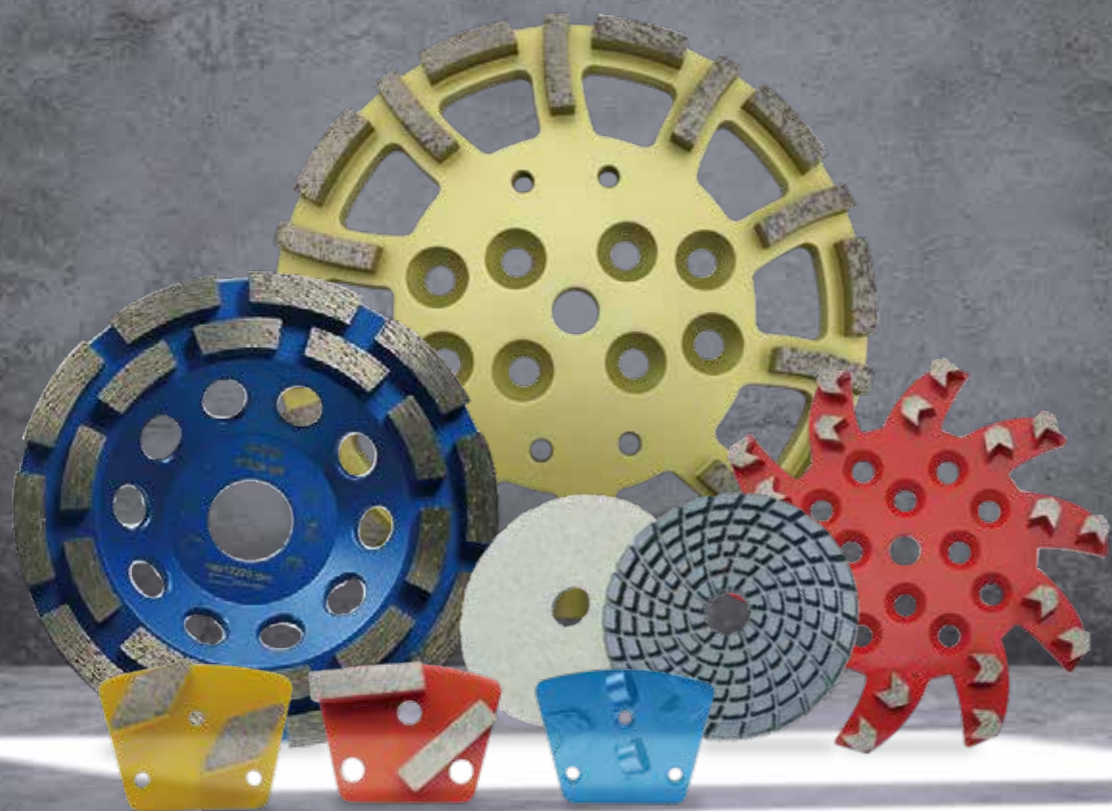



10'' Grinding head

Bycon Grinding head are designed to give optimum performance in concrete preparation, levelling concrete surfaces and removal of various thin coatings. Various grits for choice and Soft, Medium, Hard, Very Hard bond for choice based on your surface preparation request.

	Art number	Diameter(mm)	Segment(mm)	Grit	Bond
	3033250	250	10T*40*10*10	6#	S/M/H
		250	10T*40*10*10	16#	S/M/H
		250	10T*40*10*10	30#	S/M/H

	Art number	Diameter(mm)	Segment(mm)	Grit	Bond
	3034250	250	20T*40*10*10	6#	S/M/H
		250	20T*40*10*10	16#	S/M/H
		250	20T*40*10*10	30#	S/M/H

	Art number	Diameter(mm)	Segment(mm)	Grit	Bond
	3037250	250	12T*10	6#	S/M/H
		250	12T*10	16#	S/M/H
		250	12T*10	30#	S/M/H

	Art number	Diameter(mm)	Segment(mm)	Grit	Bond
	3038250	250	10T*10	6#	S/M/H
		250	10T*10	16#	S/M/H
		250	10T*10	30#	S/M/H

	Art number	Diameter(mm)	Segment(mm)	Grit	Bond
	3039250	250	20T*10	6#	S/M/H
		250	20T*10	16#	S/M/H
		250	20T*10	30#	S/M/H

Grinding wheel

Available with soft to hard bonds for various applications.

Various grits for choice and Very Soft, Soft, Medium,Hard, Very Hard bond for choice based on your surface preparation request.

The cup wheel are provided with 22.3mm bore holes and M14 adapter optional in order to provide more application.

Cup wheel color is optional.

	Art number	Diameter(inch)	Segment(mm)	Grit	Shape
	3032501	4"	8T*5	30#	Single row cup wheels
	3032502	5"	10T*5	30#	Single row cup wheels
	3032503	7"	14T*5	30#	Single row cup wheels

	Art number	Diameter(inch)	Segment(mm)	Grit	Shape
	3032504	4"	16T*5	30#	Double row cup wheels
	3032505	5"	20T*5	30#	Double row cup wheels
	3032506	7"	28T*5	30#	Double row cup wheels

	Art number	Diameter(inch)	Segment(mm)	Grit	Shape
	3032507	7"	6T*10	30#	Big curved cup wheels

	Art number	Diameter(inch)	Segment(mm)	Grit	Shape
	3032508	4"	5T*6	30#	L shape cup wheels
	3032509	5"	7T*6	30#	L shape cup wheels
	3032510	7"	9T*6	30#	L shape cup wheels

	Art number	Diameter(inch)	Segment(mm)	Grit	Shape
	3032511	4"	8T*5	30#	T shape cup wheels
	3032512	5"	9T*5	30#	T shape cup wheels
	3032513	7"	14T*5	30#	T shape cup wheels

	Art number	Diameter(inch)	Segment(mm)	Grit	Shape
	3032514	4"	9T*5	30#	Turbo cup wheels
	3032515	4"	18T*5	30#	Turbo cup wheels
	3032516	5"	9T*5	30#	Turbo cup wheels
	3032517	5"	18T*5	30#	Turbo cup wheels
	3032518	7"	12T*5	30#	Turbo cup wheels
	3032519	7"	24T*5	30#	Turbo cup wheels
	3032520	10"	24T*5	30#	Turbo cup wheels

	Art number	Diameter(inch)	Segment(mm)	Grit	Shape
	3032521	6"	7T*6	30#	Cup wheel
	3032522	5"	7T*6	30#	Cup wheel
	3032523	6"	9T*6	30#	Cup wheel

	Art number	Diameter(inch)	Segment(mm)	Grit	Shape
	3042182	7"	3T*8	30#	TGP cup wheel
	It's suitable for floor grinder DFG-480				

	Art number	Diameter(inch)	Segment(mm)	Grit	Shape
	3042185	7"	6T*8	30#	TGP cup wheel
	3042191	7"	6T*10	30#	TGP cup wheel
	3042197	10"	6T*10	30#	TGP cup wheel
	3042185/ 3042191 It's suitable for floor grinder DFG-480.				

	Art number	Diameter(inch)	Segment(mm)	Grit	Shape
	3042188	7"	9T*8	30#	TGP cup wheel
	3042194	7"	9T*10	30#	TGP cup wheel
	3042200	10"	9T*10	30#	TGP cup wheel
	3042200 is suitable for floor grinder DFG-250 series.				



Art number	Diameter(inch)	Segment(mm)	Grit	Shape
3033125	5"	16T*5	30#	Golden cup wheel
3033180	7"	24T*5	30#	Golden cup wheel



Grinding shoes

Bycon provide a wide range of concrete grinding shoes with various metal-bond hardness and grits sizes. It's ideal grinding tools for all kinds surface preparation applications.

Features:

1. Made of good quality diamond material, possess smooth surface.
2. Produced with exquisite workmanship, of sharpness, durable for a long service life.
3. Different connection methods available and customized ability on segment shape.



	Art number	Segment(mm)	Grit	Bond	Connector
	30412530	2T*32.5*14*13	30#	VS/S/M/H/VH	Redi-lock
	30412520	2T*32.5*14*13	20#/25#	VS/S/M/H/VH	Redi-lock
	30412516	2T*32.5*14*13	16#	VS/S/M/H/VH	Redi-lock

	Art number	Segment(mm)	Grit	Bond	Connector
	30412530D	2T*32.5*14*13	30#	VS/S/M/H/VH	Redi-lock
	30412520D	2T*32.5*14*13	20#/25#	VS/S/M/H/VH	Redi-lock
	30412516D	2T*32.5*14*13	16#	VS/S/M/H/VH	Redi-lock

Polishing pad

Polishing pad delivering excellent gloss and clarity when use for wet and dry polishing in concrete, marble, terrazzo and other hard materials. Resin-bonded polishing pads capable for all our floor grinders.

	Art number	Diameter (inch)	Diamond (mm)	Grits
	3042212	3"	12	50# ~ 3000#

	Art number	Diameter (inch)	Diamond (mm)	Grits
	3042213	3"	10	50# ~ 3000#

	Art number	Diameter (inch)	Diamond (mm)	Grits
	3042214	4"	3	50# ~ 3000#

	Art number	Diameter (inch)	Diamond (mm)	Grits
	3042215	4"	3	50# ~ 3000#
	3042216	5"	3	50# ~ 3000#

	Art number	Diameter (inch)	Diamond (mm)	Grits
	3042217	5"	3	50# ~ 3000#

	Art number	Diameter (inch)	Diamond (mm)	Grits
	3042220	9"	3	50# ~ 3000#

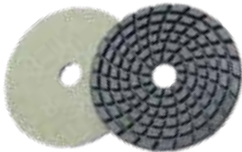
	Art number	Diameter (inch)	Diamond (mm)	Grits
	3042221	11"	5.5	50# ~ 3000#

PCD grinding shoes

To remove all type of coatings such as paint, varnish, glue, epoxy, acrylic, screed residue, VCT mastic, black tar adhesive as well as thick rubbery materials on the floor.

With high efficient for the toughest situation.

Can fit all world-wide floor grinding machines with different holders.

We also provide customized services to fulfill any special requirement.

Art No:3043x0x, please provide your design and installation way.



PCD cup wheel

Removal of epoxy, vinyls and glues.

The anti-vibration connector makes operation less exhausting. Very stable.

High removal rate.

We also provide customized service to fulfill any special requirement.

Gold PCD

	Art number	Diameter (mm)	Segment (mm)	Segment Qty
	3032410	180	40*10*10	6T
	3032411	180	40*10*10	3T

Black PCD

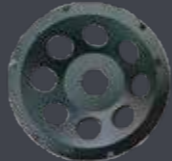
	Art number	Diameter (mm)	PCD (mm)	PCD Qty
	3032125	125	1.5*3*4	9
	3032180	180	1.5*3*4	12

Blue PCD

	Art number	Diameter (mm)	PCD (mm)	PCD Qty
	3033125	125	1.5*3*4	6
	3033180	180	1.5*3*4	6