



**SPECIALIZING IN RESISTANCE WELDING  
POWER SUPPLY  
INTEGRATION OF R&D, MANUFACTURING AND SALES**

**A World Leader in Welding Power supply Industry;  
Providing Top Notch Welding solutions.**

**Guangdong Ur Welder Co., Ltd.**

Address: 14th Floor, Building A1, West Lake Zhigu Industrial Park,  
Huicheng District, Huizhou City, Guangdong, China 516005

Email: sales1@urwelder.com sales2@urwelder.com sales3@urwelder.com

Website: <https://www.urwelder.com>

Alibaba: <https://huandianzk.en.alibaba.com> <https://urwelder.en.made-in-china.com>



Whatsapp



Wechat

**Guangdong Ur Welder Co., Ltd.**

**PROFESSIONAL SUPPLIER OF RESISTANCE WELDING CORE EQUIPMENT**

## CONTENT



### ● PART ONE ABOUT US

- 01 Company Profile
- 02 Resistance welding
- 03 Industry Application Display

### ● PART TWO PRODUCTS

- 04 Ultra Precision Inverter DC Welding Power Supply
- 05 High Frequency Invert DC Power
- 06-07 Precision Inverter DC Welding Power Supply
- 08-09 High Power Inverter DC Welding Power Supply
- 10-11 MFDC Power Supply And MFAC Power Supply
- 12 Automotive Control
- 13 UR HF Transforme
- 14 UR MFDC Transformer And UR AC Transformer
- 15 AC Welding Controller
- 16 UR AC Transformer
- 17 Welding Monitor
- 18 Pulse Heating Power
- 19 Energy Storage Welding Controller
- 20 Welding Network Group Control System
- 21 Welding Quality Monitoring System
- 22 Servo Head Controller
- 23 Pneumatic Or Servo Spot Welding Mechnism
- 24 Pneumatic Or Servo Clamping Welding Mechnism
- 25-26 Welding Gun And Accessory

## 01 Company Profile

**Guangdong Ur Welder Co., Ltd.** is a high-tech enterprise integrating R&D, manufacturing and sales of resistance welding systems and resistance welding core technicals, such as resistance welding power supply, precision spot welder, welding monitor, etc. All of the company's resistance welding products are independent research and development, with all the independent intellectual property rights.

Ur Welder 's creative team has more than ten years of experience in resistance welding industry, and now we have formed a strong R&D team with professors and doctors as the core. Ur Welder insists on investing a large amount of R&D funds every year to maintain the competitiveness of its products and to ensure the leading technical R&D strength.

Since its establishment, Ur Welder has been committed to serving the high-tech manufacturing industry, providing advanced metal welding products and solutions for global high-end customers in the fields of automobile body, automobile parts, automobile electronics, motor stand-alone, new energy batteries, solar photovoltaic, electric light source, enameled wires, coils, wiring harnesses, capacitors, protectors, sensors, relays, optical communications, and pin vibration industry, etc. Ur Welder is a leading supplier of advanced metal welding products and solutions for the global high-end customers.

After more than ten years of development, Ur Welder has completed the layout of multiple industrial bases, not only in the domestic market in the forefront, in Europe and Asia has also established a good business channels and technical cooperation, the products have been sold to more than ten countries and regions, recognized by many well-known domestic and foreign enterprises and customers.



## 02 Resistance Welding

### Principle Of Resistance Welding Technology

Resistance welding is a method of heating a workpiece to a molten or plastic state by using the resistive thermal effect produced by the flow of electric current through the contact surfaces and adjacent areas to form a metallic bond. There are four main resistance welding methods: spot welding, seam welding, projection welding, butt welding.

Resistance welding is characterized by high productivity, low cost, material saving and easy automation, so it is widely used in aviation, aerospace, energy, electronics, automotive, light industry and other industries, and is one of the important welding processes.

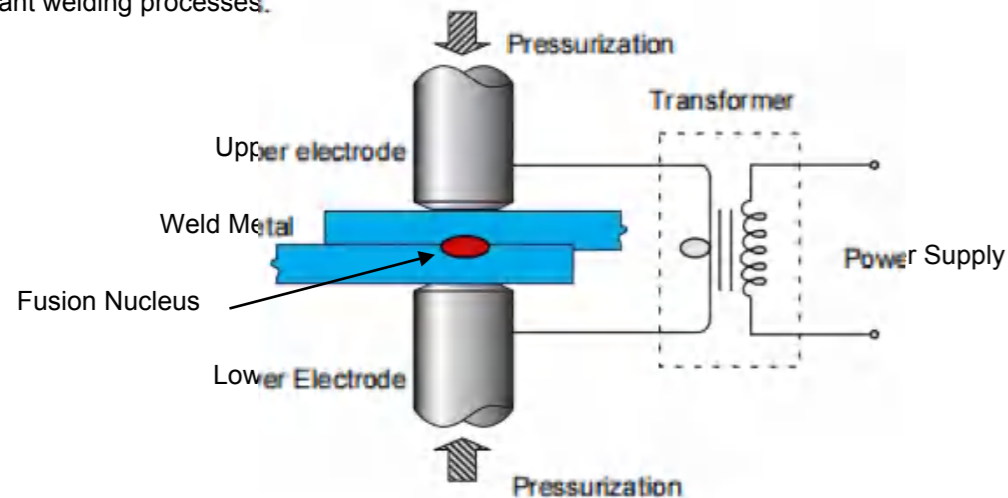

### 5 Elements Of Resistance Welding



Electric Current



Material



Pressure



Time



Electrode

Resistance welding to achieve good welding results, there are five major influencing factors are more critical: welding current, welding material, welding pressure, welding time and the electrode shape and material, which the current on the heat production effect than the other four are large, therefore, in the spot welding process, it is a must be strictly controlled parameters, so that the welding power supply, accurate and stable output becomes Especially important.

## Types And Characteristics Of Welding Power Supply

### DC Inverter Type

It has the advantages of continuous heat supply, high thermal efficiency, short welding time, low heat impact, and suppression of power loss. The control of the inverter-type high-speed circuit prevents spatter and stabilizes welding quality, making it suitable for ultra-precision welding. The small size of the transformer makes it easy to set up an automatic production line.

### AC Inverter Type

Excellent thermal efficiency and stable welding quality are the advantages of inverter welding power sources. Since the characteristic polarity effect of AC is very small, it is the most suitable welding power source for hot press welding because it can obtain equal welding effect.

### Waveform Characteristics Of Various Welding Power Supplies

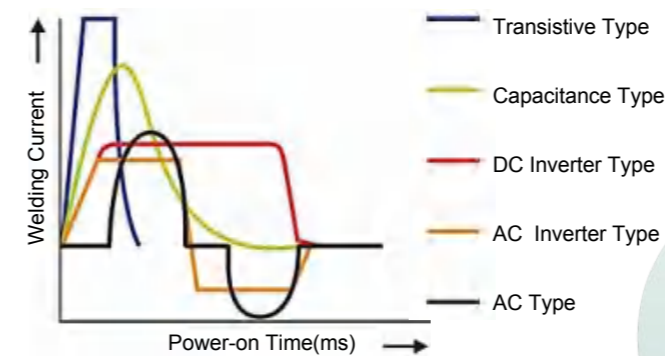

### Capacitance Type

Energy storage type welding power source obtains high current by charging and discharging a capacitor, and is suitable for materials with superior thermal conductivity, such as aluminum, nickel, copper, and so on. The advantage is that the current rises quickly, but the angle of inclination cannot be controlled and spattering is easily generated.

### AC Type

AC type welding power source is the simplest welding power source by controlling the AC conduction angle. It is not suitable for ultra-precision welding because the thermal efficiency is relatively poor and the workpiece is easily affected by heat. It is more suitable for iron materials that are easy to weld.

### Transistive Type

A welding power supply that controls the current with a transistor, which suppresses spattering and is suitable for ultra-precision welding. The advantage is that the current control speed is very fast, and it is suitable for welding very fine wires (filaments, etc.).

## 03 Industry Application Display

### Automotive/Automotive Electronics Industry

Automotive Wire Harness / Body Frame / Tailpipe / Fuel Tank/Electronic Sensor / Ignition Coil Welding



### Motor/Battery Industry

Motor/End Cap/Carbon Brush/Hollow Cup Motor Lead/Battery Lug/Connecting/Battery Cell/PACK Welding



### Solar /Photovoltaic Power Industry

Photovoltaic Connectors / Molybdenum Sheets To Tungsten Rods / Nickel Cups To Fusible Alloy / welding, Tungsten Rods To Nickel Rods Butt-welding



### Capacitor/protector industry

Capacitor Pin / Air Conditioner Protector / Automotive Resistance Protector / Ceramic Discharge Tube Welding



### Relay/Electrical switch industry

All Kinds Of Sensor Lead Welding, All Kinds Of Contacts And Reed Welding



### Enameled wire/coil industry

Direct Soldering Of Various Enameled Wires Without Paint Removal, Automotive Ignition Coils, Solenoid Valve Coils Welding



### Optical communication/crystal oscillator industry

Diode/Connector Welding, Optical Module Base Sealing, All Kinds Of Crystal Oscillator Base Welding, Shell Sealing Welding.

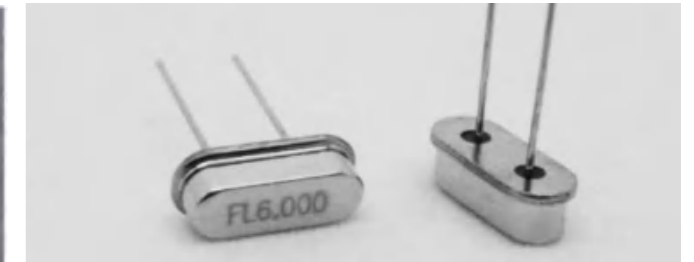

### Wiring harness/hardware and home appliance industry

Welding of wires, welding of sheet metal parts, welding of small electrical appliances.



## 04 Ultra Precision Inverter DC Welding Power Supply

### Product Features

- 1A precise current regulation can be realized.
- Five working frequencies selectable (1KHz/2KHz/3KHz/4KHz/5KHz).
- Six welding control modes (constant peak current, constant secondary current, constant voltage, constant power, constant pulse width, hybrid control).
- Quality Judgment And Control Function: Instantaneous and average values of current, voltage and power can be monitored at the same time, and pressure and displacement values can also be monitored. The upper and lower limits of the parameters can be set, and the pressure trigger and displacement depth interrupt functions are supported.
- Quality Traceability Function: Database function, can store more than 5 million welding data of welding points, and support U disk export.
- Welding Process Visualization: Man-machine touch interface with oscilloscope and detector functions, real-time display of current, voltage, power, resistance and other 8 real waveforms and corresponding welding data.
- Support multi-stage discharge, also has a slow rise and fall function.
- Diagnostic protection function: with more than twenty kinds of welding fault diagnosis, welding protection module, as well as monitoring and alarm function.
- Automation control: Equipped with rich I/O interfaces, supporting a variety of communication protocols (RS-232, RS-485, Ethernet, etc.).
- It is extremely suitable for ultra-precise electronic components and medical precision parts.



**IDP-1210 Ultra precision high-frequency inverter DC welding power supply**

### Power Supply Specifications

Model	IDP-1210	
Supply Voltage	3-phase 380V (50/60Hz)	
Control Frequency	1kHz/2kHz/3kHz/4kHz/5kHz	
Max. Output Current	1000A	
Control Method	Constant Pulse Width/Constant Peak Primary/Constant Secondary Current/Constant Secondary Voltage/Constant Power/Hybrid Control	
Number Of Welding Norms	32 Group Norms	
Welding Time Setting	Pre-squeeze Time	0-9999ms
	Squeeze Time	0-9999ms
	Up slope 1 Time	0-9999cyc
	Welding 1 Time	0-9999cyc
	Down slope 1 Time	0-9999cyc
	Cooldown	0-9999cyc
	Up slope 2 Time	0-9999cyc
	Welding 2 Time	0-9999cyc
	Down Slope 2 Time	0-9999cyc
	Up slope 3 Time	0-9999cyc
	Welding 3 Time	0-9999cyc
	Down slope 3 Time	0-9999cyc
	Holding Time	0-9999ms
	Rest Period	0-9999ms
End Time	0-9999ms	
Number Of Cycles	0-9	
Setting Range For Secondary Current	0.1-1.00KA	
Setting Range Of Pulse Width	1%-100%	
Setting Range For Secondary Voltage	0.01-10V	
Power Setting Range	0.1-10KW	
Sizes	549*220*320mm	
Weight	22KG	
Matching Transformer	IDT-40A	
Communication Method	RS-232/RS-485/Ethernet , etc.	

### Transformer Specifications

Model	IDT-40A
Supply Voltage	PWM 500V
Rated Power	15KVA
Rated Primary Voltage	500V
Unloaded Secondary Voltage	10V
Max. Utilization Rate	4000A(5%)
Cooling Method	Air-cooling
Input Frequency	1-5kHz
Transformer Volume Ratio	50:1
Sizes	424*205*280mm
Weight	18.5KG

## 05 High Frequency Invert DC Power

### Product Features

- Supports 1KHz/2KHz/3KHz/4KHz/5KHz working frequency switching freely.
- Six welding control modes, including constant peak current, constant secondary current, constant voltage, constant power, constant pulse width and advanced mixed control, can meet the welding needs of materials of different shapes.
- The 7-inch high-definition touch screen has built-in oscilloscope and detector functions, which can display 8 real welding waveforms such as current, voltage, power, resistance waveform, etc.
- Supports 32 sets of parameter storage, convenient for multi-variety welding, rich I/O interfaces, supports multiple communication protocols (MODBUS, RS-232, RS-485, supports expansion of ModBus TCP/IP, EtherNet/IP, PROFINET, Devicenet, EtherCAT, etc.), convenient for external PLC automation control or robot communication protocol control.
- It supports multi-stage welding discharge, and can also set the slow rise and slow fall functions of each welding stage separately, which is helpful for welding formation and effectively solves welding spatter and ensures welding stability.
- Built-in up to 22 types of welding fault diagnosis, welding protection module, and monitoring alarm function to ensure the safety of the entire welding process.
- Built-in electrode grinding function and electrode grinding warning function can set the number of electrode welding times. After reaching the number, an alarm will be issued to remind you to grind the electrode to ensure the welding effect.



**IDP-3420 / IDP-5420 High Frequency Precision Inverter DC Resistance Welding Power Supply**

### Technical Parameters

Model	IDP-3420	IDP-5420
Supply Voltage	220 V / 380 V (50/60Hz)	
Control Frequency	1kHz / 2kHz / 3kHz / 4kHz / 5kHz	
Maximum output current	3000A	5000A
Maximum Power	10KVA	15KVA
Control Method	Fixed pulse width/fixed primary peak/fixed secondary current/fixed secondary voltage/fixed power/mixed control	
Welding specification number	32 Group	
Welding Time	Pre-squeeze Time	0-9999ms
	Squeeze Time	0-9999ms
	Up slope 1 Time	0-9999cyc
	Welding 1 Time	0-9999cyc
	Down slope 1 Time	0-9999cyc
	Cooldown	0-9999cyc
	Up slope 2 Time	0-9999cyc
	Welding 2 Time	0-9999cyc
	Down Slope 2 Time	0-9999cyc
	Up slope 3 Time	0-9999cyc
	Welding 3 Time	0-9999cyc
	Down slope 3 Time	0-9999cyc
	Holding Time	0-9999ms
	Rest Period	0-9999ms
End Time	0-9999ms	
Cycle times	0-99	
Current setting range	0.05 ~ 3.00kA	0.05-5.00KA
Current adjustment range	10A	
Current pre-check	Support	
Current/voltage/power monitoring	0.00 ~ 3kA	0.00-5KA
Communication Protocol	Standard RS-232, RS-485, optional Ethernet (TCP/IP)	
Cooling method	Air Cooling	
Transformer turns ratio	30:1/50:1	
Transformer no-load secondary voltage	10V/10V	
High utilization rate	3000A (5%)	5000A (5%)
weight	21Kg	22Kg

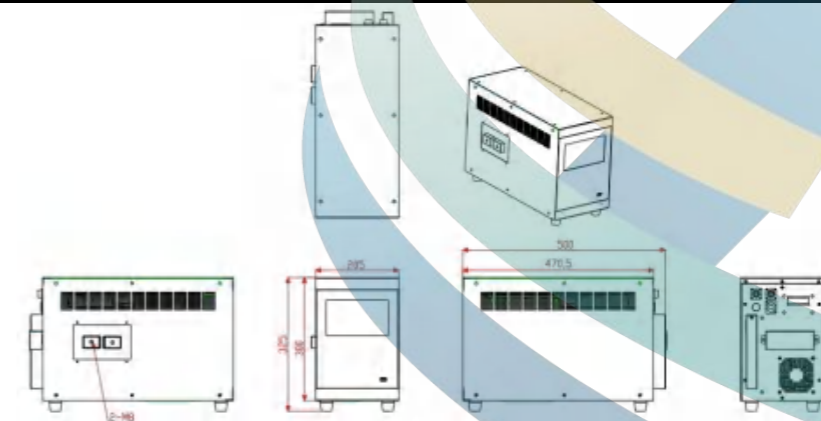

## 06 Precision Inverter DC Welding Power Supply

### Product Features

- Five working frequencies selectable (1KHz/2KHz/3KHz/4KHz/5KHz)
- Six welding control modes (constant peak current, constant secondary current, constant voltage, constant power, constant pulse width, hybrid control)
- Quality Judgment And Control Function: Instantaneous and average values of current, voltage and power can be monitored at the same time, and pressure and displacement values can also be monitored. The upper and lower limits of the parameters can be set, and the pressure trigger and displacement depth interrupt functions are supported.
- Quality Traceability Function: The database can store more than 5 million welding data of welding points, and support U disk export.
- Welding Process Visualization: Man-machine touch interface with oscilloscope and detector functions, real-time display of current, voltage, power, resistance and other 8 real waveforms and corresponding welding data.
- Support multi-stage discharge, also has a slow rise and fall function
- Diagnostic Protection Function: With more than twenty kinds of welding fault diagnosis, welding protection module, as well as monitoring and alarm function.
- Automation control: Equipped with rich I/O interfaces, supporting a variety of communication protocols (RS-232, RS-485, Ethernet, etc.).



**IDP-5210 / IDP-8210 High Frequency Precision Inverter DC Resistance Welding Power Supply**

### Power Supply Specifications

Model	IDP-5210	IDP-8210
Supply Voltage	3-phase 380V (50/60Hz)	
Control Frequency	1kHz/2kHz/3kHz/4kHz/5kHz	
Max. Output Current	4000A	8000A
Rated Power	15kVA	25kVA
Control Method	Constant Pulse Width/Constant Peak Primary/Constant Secondary Current/Constant Secondary Voltage/Constant Power/Hybrid Control	
Number Of Welding Norms	32 Group Norms	
Welding Time Setting	Pre-squeeze Time	0-9999ms
	Squeeze Time	0-9999ms
	Up slope 1 Time	0-9999cyc
	Welding 1 Time	0-9999cyc
	Down slope 1 Time	0-9999cyc
	Cooldown	0-9999cyc
	Up slope 2 Time	0-9999cyc
	Welding 2 Time	0-9999cyc
	Down Slope 2 Time	0-9999cyc
	Up slope 3 Time	0-9999cyc
	Welding 3 Time	0-9999cyc
	Down slope 3 Time	0-9999cyc
	Holding Time	0-9999ms
	Rest Period	0-9999ms
End Time	0-9999ms	
Number Of Cycles	0-9	
Setting Range For Secondary Current	0.1-4.00KA	0.1-8.00KA
Setting Range Of Pulse Width	1%-100%	
Setting Range For Secondary Voltage	0.01-10V	
Sizes	549*220*320mm	
Weight	22KG	
Matching Transformer	IDT-40A	IDT-80A
Communication Method	RS-232/RS-485/Ethernet , etc.	

### Transformer Specifications

Model	IDT-40A	IDT-80A
Supply Voltage	PWM 500V	PWM 500V
Rated Power	15KVA	25KVA
Rated Primary Voltage	500V	500V
No Load Secondary Voltage	10V	11V
Max. Utilization Rate	4000A(5%)	8000A(10%)
Cooling Method	Air-cooling	Water-cooling
Input Frequency	1-5kHz	
Transformer Volume Ratio	50:1	45:1
Sizes	424*205*280mm	440*205*280mm
Weight	18.5KG	22KG

## 07 Precision Inverter DC Welding Power Supply

### Product Features

- Equipped with a remote programmer in an all-aluminum housing for external remote programming.
- Five working frequencies selectable (1KHz/2KHz/3KHz/4KHz/5KHz).
- Six welding control modes (constant peak current, constant secondary current, constant voltage, constant power, constant pulse width, hybrid control).
- Quality Judgment And Control Function: Instantaneous and average values of current, voltage and power can be monitored at the same time, and pressure and displacement values can also be monitored. The upper and lower limits of the parameters can be set, and the pressure trigger and displacement depth interrupt functions are supported.
- Quality Traceability Function: The database can store more than 5 million welding data of welding points, and support U disk export.
- Welding Process Visualization: Man-machine touch interface with oscilloscope and detector functions, real-time display of current, voltage, power, resistance and other 8 real waveforms and corresponding welding data.
- Support multi-stage discharge, also has a slow rise and fall function.
- Diagnostic Protection Function: With more than twenty kinds of welding fault diagnosis, welding protection module, as well as monitoring and alarm function.
- Automation control: Equipped with rich I/O interfaces, supporting a variety of communication protocols (RS-232, RS-485, Ethernet, etc.).



IDP-300 Precision Inverter DC Welding Power Supply

### Power Supply Specifications

Model	IDP-300	
Supply Voltage	3-phase 380V (50/60Hz)	
Control Frequency	1kHz/2kHz/3kHz/4kHz/5kHz	
Max. Output Current	15000A	
Rated Power	90kVA	
Control Method	Constant Pulse Width/Constant Peak Primary/Constant Secondary Current/Constant Secondary Voltage/Constant Power/Hybrid Control	
Number Of Welding Norms	32 Group Norms	
Welding Time Setting	Pre-squeeze Time	0-9999ms
	Squeeze Time	0-9999ms
	Up slope 1 Time	0-9999cyc
	Welding 1 Time	0-9999cyc
	Down slope 1 Time	0-9999cyc
	Cooldown	0-9999cyc
	Up slope 2 Time	0-9999cyc
	Welding 2 Time	0-9999cyc
	Down Slope 2 Time	0-9999cyc
	Up slope 3 Time	0-9999cyc
	Welding 3 Time	0-9999cyc
	Down slope 3 Time	0-9999cyc
	Holding Time	0-9999ms
	Rest Period	0-9999ms
End Time	0-9999ms	
Number Of Cycles	0-9	
Setting Range For Secondary Current	0.3-15.00KA	
Setting Range Of Pulse Width	1%-100%	
Setting Range For Secondary Voltage	0.01-10V	
Power Setting Range	0.2-60KW	
Sizes	549*220*320mm	
Weight	22KG	
Matching Transformer	IDT-915C	
Communication Method	RS-232/RS-485/Ethernet , etc.	

### Transformer Specifications

Model	IDT-915C
Supply Voltage	PWM 500V
Rated Power	90KVA
Rated Primary Voltage	500V
Unloaded Secondary Voltage	11V
Max. Utilization Rate	15000A(10%)
Cooling Method	Water-cooling
Input Frequency	1-5kHz
Transformer Volume Ratio	45:1
Sizes	343*146*106mm
Weight	17KG

## 08 High Power Inverter DC Welding Power Supply

### Product Features

- Equipped with remote program. It can realize external remote program settings.
- Five working frequencies selectable (1KHz/2KHz/3KHz/4KHz/5KHz)
- Six welding control modes (constant peak current, constant secondary current, constant voltage, constant power, constant pulse width, hybrid control)
- Quality Judgment And Control Function: Instantaneous and average values of current, voltage and power can be monitored at the same time, and pressure and displacement values can also be monitored. The upper and lower limits of the parameters can be set, and the pressure trigger and displacement depth interrupt functions are supported.
- Quality Traceability Function: The database can store more than 5 million welding data of welding points, and support U disk export.
- Welding Process Visualization: Man-machine touch interface with oscilloscope and detector functions, real-time display of current, voltage, power, resistance and other 8 real waveforms and corresponding welding data.
- Support multi-stage discharge, also has a slow rise and fall function
- Diagnostic Protection Function: With more than twenty kinds of welding fault diagnosis, welding protection module, as well as monitoring and alarm function.
- More suitable for the automotive industry, the whole series standard with adaptive intelligent welding function, according to the welding process of external conditions change, automatically adjust the current and time, to ensure the welding quality, to solve the problem of shunt, edge welding, non-conductive gap welding, pressure changes, plate thickness inconsistency and so on.



### Power Supply Specifications

Model	IDP-600	IDP-800	IDP-1000
Supply Voltage	3-phase 380V (50/60Hz)		
Control Frequency	1kHz/2kHz/3kHz/4kHz/5kHz		
Max. Output Current	600A(Primary)	800A(Primary)	1000A(Primary)
Rated Power	120kVA	170kVA	220kVA
Control Method	Constant Pulse Width/Constant Peak Primary/Constant Secondary Current/Constant Secondary Voltage/Constant Power/Hybrid Control		
Number Of Welding Norms	32 Group Norms		
Welding Time Setting	Pre-squeeze Time	0-9999ms	
	Squeeze Time	0-9999ms	
	Up slope 1 Time	0-9999cyc	
	Welding 1 Time	0-9999cyc	
	Down slope 1 Time	0-9999cyc	
	Cooldown	0-9999cyc	
	Up slope 2 Time	0-9999cyc	
	Welding 2 Time	0-9999cyc	
	Down Slope 2 Time	0-9999cyc	
	Up slope 3 Time	0-9999cyc	
	Welding 3 Time	0-9999cyc	
	Down slope 3 Time	0-9999cyc	
	Holding Time	0-9999ms	
	Rest Period	0-9999ms	
End Time	0-9999ms		
Number Of Cycles	0-9		
Setting Range For Secondary Current	0.1-25.00KA	0.2-35.00KA	0.3-45.00KA
Setting Range Of Pulse Width	1%-100%		
Setting Range For Secondary Voltage	0.02-10V		
Sizes	578*600*305mm		
Matching Transformer	IDT-925C	IDT-935C	IDT-945C
Communication Method	RS-232/RS-485/Ethernet , etc.		

## 09 High Power Inverter DC Welding Power Supply

### Product Features

- Equipped with remote programmer, can realize external remote programming settings.
- Five working frequencies selectable (1KHz/2KHz/3KHz/4KHz/5KHz).
- Six welding control modes (constant peak current, constant secondary current, constant voltage, constant power, constant pulse width, hybrid control).
- Quality Judgment And Control Function: Instantaneous and average values of current, voltage and power can be monitored at the same time, and pressure and displacement values can also be monitored. The upper and lower limits of the parameters can be set, and the pressure trigger and displacement depth interrupt functions are supported.
- Quality Traceability Function: The database can store more than 5 million welding data of welding points, and support U disk export.
- Welding Process Visualization: Man-machine touch interface with oscilloscope and detector functions, real-time display of current, voltage, power, resistance and other 8 real waveforms and corresponding welding data.
- Support multi-stage discharge, also has a slow rise and fall function.
- Diagnostic Protection Function: With more than twenty kinds of welding fault diagnosis, welding protection module, as well as monitoring and alarm function.
- More suitable for the automotive industry, the whole series standard with adaptive intelligent welding function, according to the welding process of external conditions change, automatically adjust the current and time, to ensure the welding quality, to solve the problem of shunt, edge welding, non-conductive gap welding, pressure changes, plate thickness inconsistency and so on.



### Power Supply Specifications

Model	IDP-600P	IDP-800P	IDP-1000P
Supply Voltage	3-phase 380V (50/60Hz)		
Control Frequency	1kHz/2kHz/3kHz/4kHz/5kHz		
Max. Output Current	600A(Primary)	800A(Primary)	1000A(Primary)
Rated Power	120kVA	170kVA	220kVA
Control Method	Constant Pulse Width/Constant Peak Primary/Constant Secondary Current/Constant Secondary Voltage/Constant Power/Hybrid Control		
Number Of Welding Norms	32 Group Norms		
Welding Time Setting	Pre-squeeze Time	0-9999ms	
	Squeeze Time	0-9999ms	
	Up slope 1 Time	0-9999cyc	
	Welding 1 Time	0-9999cyc	
	Down slope 1 Time	0-9999cyc	
	Cooldown	0-9999cyc	
	Up slope 2 Time	0-9999cyc	
	Welding 2 Time	0-9999cyc	
	Down Slope 2 Time	0-9999cyc	
	Up slope 3 Time	0-9999cyc	
	Welding 3 Time	0-9999cyc	
	Down slope 3 Time	0-9999cyc	
	Holding Time	0-9999ms	
	Rest Period	0-9999ms	
End Time	0-9999ms		
Number Of Cycles	0-9		
Setting Range For Secondary Current	0.1-25.00KA	0.2-35.00KA	0.3-45.00KA
Setting Range Of Pulse Width	1%-100%		
Setting Range For Secondary Voltage	0.02-10V		
Sizes	461*389*221mm		
Matching Transformer	IDT-925C	IDT-935C	IDT-945C
Communication Method	RS-232/RS-485/Ethernet , etc.		

## 10 MFDC Power Supply

### Product Features

- Equipped with remote programmer, It can realize external remote program settings.
- One working frequency (1KHz or 4KHz).
- One control modes (constant peak current).
- 3 stages weldings: preheating, weld, tempering. Regarding welding, you can set the stepping, reducing, and recycling times.
- Free program I/O outlets: program 3 output, great connection with PLC, robots connection.
- Counting system: welding qty, production qty, carton qty, electrode repairing qty are all covered. It improves the quality control of welding.
- Communication and BCD code control: It is ok to connect remote control, PLC etc other remote digital control.
- Secondary toroidal coil displays real on time welding current which gives feedback to controller to adjust the accuracy of current.
- Easy Setting. It is ok to copy the same action data to be another line. It save time to set welding program.
- Limit control: 3 levels management.
- Data management: the current/ welding time/ voltage/ action code are stocked and USB copy to computer to study for quality checking and tracibility.
- Alarm saving: the quality issue will be recorded to trace.
- Accuracy: 0.5%.



### Power Supply Specifications

MFDC							
Item#	IDW-400L	IDW-600L	IDW-800T	IDW-1000T	IDW-1200T	IDW-1800T	IDW-2400T
Input	3*380V +/-10%, 50/60HZ ( Option 220V / 440V available)						
Max output current	400A	600A	900A	1100A	1300A	1800A	2400A
Rated Power	90KVA	120KVA	180KV A	200KVA	250KVA	350KV A	350KV A*2
Control Mode	Constant Peak current or Constant conduction angle						
Frequency	1kHz or 4kHz						
Air Valve Qty	Standard 4 air vales, gantry welding standard 10 air valves. Max 17 air valves.						
Communication	RS485						
Current arrange	0-400A 0-20KA	0-600A 0-28KA	0-900A 0-32KA	0-1000A 0-50KA	0-1300A 0-60KA	0-1800A 0-72KA	0-2400A 0-96KA
Max welding Spec qty	32 sets, it is ok to extend 256 sets ( each specification has different welding data)						
Work condition	Temperature 0-45 degrees Celsius (no icing) moderately less than 85% (no dewdrop phenomenon) no strong magnetism, no severe vibration and impact, no corrosive gas and conductive dust						

# 11 MFAC Power Supply

## Product Features

- Equipped with remote program. It can realize external remote program setting.
- One working frequency (15-400Hz).
- One control modes (constant peak current).
- 3 stages weldings: preheating, weld, tempering. Regarding welding, you can set the stepping, reducing, and recycling times.
- Free program I/O outlets: program 3 output, great connection with PLC, robots connection.
- Counting system: welding qty, production qty, carton qty, electrode repairing qty are all covered. It improves the quality control of welding.
- Communication and BCD code control: It is ok to connect remote control, PLC etc other remote digital control.
- Secondary toroidal coil displays real on time welding current which gives feedback to controller to adjust the accuracy of current.
- Easy Setting. It is ok to copy the same action data to be another line. It save time to set welding program.
- Limit control: 3 levels management.
- Data management: the current/ welding time/ voltage/ action code are stocked and USB copy to computer to study for quality checking and tracibility.
- Alarm saving: the **quality issue will be recorded to trace**.
- Accuracy: 0.5%.



## Power Supply Specifications

MFAC								
Item#	IAW-400L	IAW-600T	IAW-800T	IAW-1000T	IAW-1200T	IAW-1800T	IAW-2400T	IAW-3600T
IGBTModel	300A	450A	600A	800A	900A	1400A	1800A	2800A
Input power	3*380V +/-10%, 50/60HZ ( Option 220V / 440V available)							
Max output (primary)	400A	600A	800A	1000A	1200A	1800A	2400A	3600A
Rated Power(KVA)	50	80	100	125	150	200	250	350*2
Secondary Voltage(V)	11.25	11.25	11.25	11.25	13.5	13.5	13.5	13.5
Air Switch(A)	100	125	125	160	200	200	200	400
Control Mode	Constant Peak current or Constant conduction angle							
Frequency	15-400HZ							
Air Valve Qty	Standard 4 air vales, gantry welding standard 10 air valves. Max 17 air valves.							
Communication	RS-485							
Current Range(A)	0-350 0-20KA	0-500 0-28KA	0-600 0-33KA	0-900 0-35KA	0-1000 0-36KA	0-1500 0-40KA	0-1600 0-45KA	0-3000 0-70KA
Max Weld Spec Qty	32 sets, it is ok to extend 256 sets ( each specification has different welding data)							
Work Condition	Temperature 0-45 degrees Celsius (no icing) moderately less than 85% (no dewdrop phenomenon) no strong magnetism, no severe vibration and impact, no corrosive gas and conductive dust							

## 12 Automotive Control

### Product Features

- Equipped with remote programmer, can realize external remote programming settings.
- Five working frequencies selectable (1KHz/2KHz/3KHz/4KHz/5KHz).
- Tree welding control modes (constant primary current, constant secondary current and constant pulse width).
- The 7-inch HD touchscreen integrates oscilloscope and detector functions, displaying up to 8 real-time welding waveforms (current, voltage, power, resistance, etc.) and corresponding data for analysis. This enables customers to monitor welding consistency/quality with intuitive debugging.
- The welding circuit monitoring function can be used to set the upper and lower limit alarms of the circuit coefficient to effectively determine whether the welding machine circuit is normal, whether the conductive copper strip is aging, broken, shunted, and other abnormal conditions.
- This machine features a pre-weld low-current check to prevent electrode cap explosions from insufficient clamp pressure during discharge welding and to detect missing or misaligned workpieces.
- More suitable for the automotive industry, the entire series is equipped with adaptive intelligent welding function as standard, which automatically adjusts the current and time according to changes in external conditions during the welding process to ensure welding quality and solve problems such as shunt welding, edge welding, non-conductive gap welding, pressure changes, inconsistent plate thickness, etc.



### Power Supply Specifications

Model	IDP-620	IDP-820	IDP-1220	IDP-1620
Input Power	3 *380 V (50/60Hz)			
Control Frequency	1kHz / 2kHz / 3kHz / 4kHz / 5kHz			
Max Output ( Primary)	600A(Primary)	800A(Primary)	1200A(Primary)	1600A(Primary)
Control Mode	constant primary current, constant secondary current, conduction angle control ( 3 options)			
Specifications qty	256			
Welding time Setting	Pre-squeeze Time	0-9999ms		
	Squeeze Time	0-9999ms		
	Up slope 1 Time	0-9999ms		
	Welding 1 Time	0-9999ms		
	Down slope 1 Time	0-9999ms		
	Cooldown	0-9999ms		
	Up slope 2 Time	0-9999ms		
	Welding 2 Time	0-9999ms		
	Down Slope 2 Time	0-9999ms		
	Up slope 3 Time	0-9999ms		
	Welding 3 Time	0-9999ms		
	Down slope 3 Time	0-9999ms		
	Holding Time	0-9999ms		
	Rest time	0-9999ms		
End Time	0-9999ms			
Number of cycles	0-99			
Current Setting Range	1 ~ 30kA	1 ~ 40kA	1 ~ 50kA	1 ~70kA
Current adjustment Range	10A			
Current Control Precision	≤1%			
Impedance control accuracy	1%			
Tripping function	YES			
Offline data upload	YES			
Circuit Monitor	YES			
Adaptive Function	YES			
Current Prechecking	YES			
Current Monitor	0.01 ~ 35kA	0.01 ~ 45kA	0.01 ~ 55kA	0.01 ~ 75kA
Welding Repeated Repairing	YES			
Communication	standard: RS-232、RS-485、ModBus TCP/IP customized: EtherNet/IP, ProfiNet, ProfiBus, EtherCAT, DeviceNet			
Cooling	water			

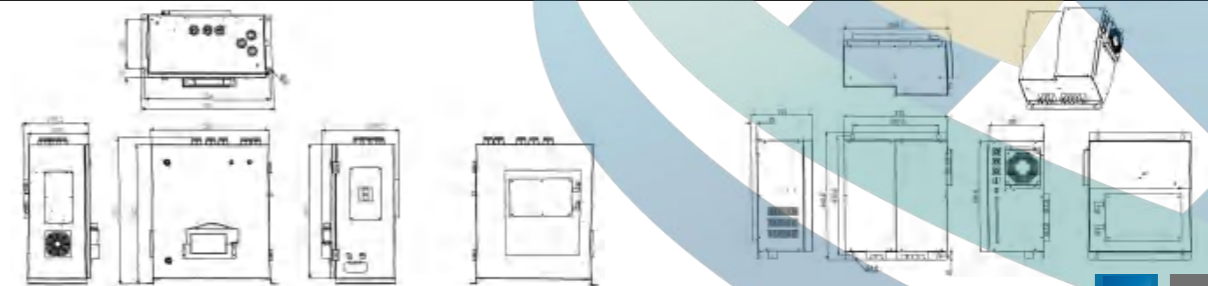

# 13 UR HF Transformer

## Product Features

- IDT series high-frequency welding transformer, by the rectifier module, core, winding, water-cooled circulation of several parts.
- It has the characteristics of low output secondary voltage, high current and fast current rise.
- Supports 1KHz/2KHz/3KHz/4KHz/5KHz working frequency switching freely.



IDT-915C

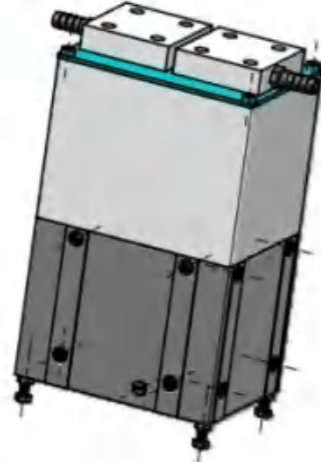

IDT-925C

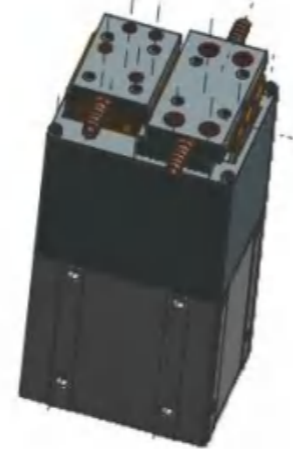

IDT-935C



## Transformer Specifications

Model	IDT-915C	IDT-925C	IDT-935C	IDT-945C(pend)
Supply Voltage	PWM 500V	PWM 500V	PWM 500V	PWM 500V
Rated Power	90KVA	120KVA	170KVA	220KVA
Rated Primary Voltage	500V	500V	500V	500V
No Load Secondary Voltage	11V	9.1V	11.3V	11V
Max. Output Current (Max. Utilization Rate)	15000A(10%)	25000A(5%)	35000A(10%)	45000A(10%)
Cooling Method	Water-cooling	Water-cooling	Water-cooling	Water-cooling
Output Frequency	1-5kHz	1-5kHz	1-5kHz	1-5kHz
Transformer Volume Ratio	45:1	55:1	44:1	45:1
Size	343*146*106mm	268*160*125mm	334*160*125mm	343*146*106mm
Weight	17KG	21.2KG	30KG	47KG

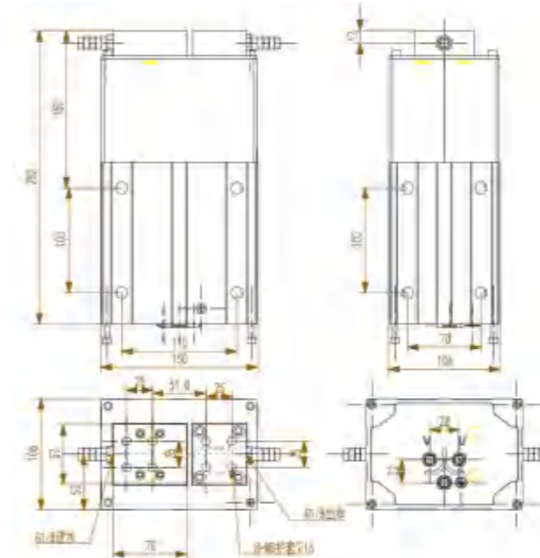

IDT-915C Dimension Drawing

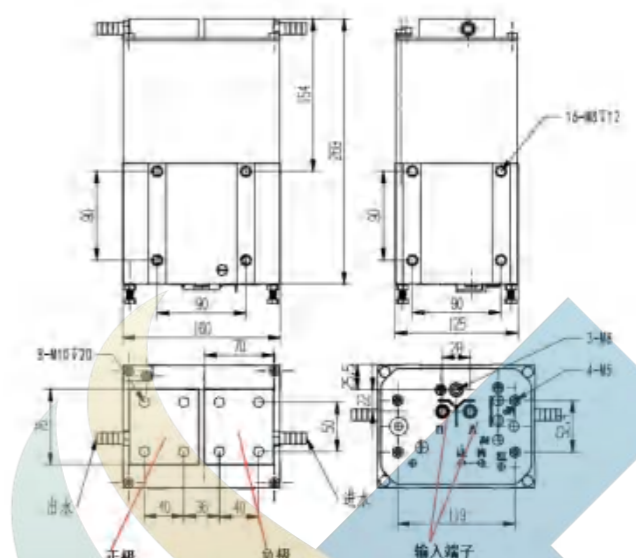

IDT-925C Dimension Drawing

# 14 UR MFDC Transformer

## Product Features

- UR series intermediate-frequency transformer, by the rectifier module, core, winding, water-cooled circulation of several parts.
- Transformer secondary output has low voltage and high current.
- Transformer has a low continuous load rate, operates discontinuously.
- Transformer has a large transmission power.
- One working frequency (1KHz or 4KHz).
- Low-voltage, high-current design for safe and efficient welding.
- It outputs direct current, due to the current bunching effect of direct current, the welding heat can be concentrated and the heat - affected zone around the weld joint can be reduced. This characteristic is particularly important for the welding of multilayer boards and thick plates.
- The magnetic core of the intermediate-frequency transformer is made of nano-amorphous iron-based strips. Nano-amorphous iron-based materials have the advantages of high magnetic flux density, high magnetic permeability, high Curie temperature and high thermal stability, as well as small eddy current loss, low iron loss and high magnetic induction intensity.



## Transformer Specifications

Model	URD-90	URD-130	URD-180	URD-240	URD-350
Supply Voltage	PWM 500V	PWM 500V	PWM 500V	PWM 500V	PWM 500V
Rated Power	90KVA	130KVA	180KVA	240KVA	350KVA
Rated Primary Voltage	500V	500V	500V	500V	500V
No Load Secondary Voltage	9V	10V	10V	12.5V	12.5V
No-Load Loss	20000A(20%)	30000A(20%)	40000A(20%)	50000A(20%)	60000A(20%)
Cooling Method	Water-cooling	Water-cooling	Water-cooling	Water-cooling	Water-cooling
Input Frequency	1kHz	1kHz	1kHz	1kHz	1kHz
Transformer Volume Ratio	55:1	55:1	50:1	44:1	40:1
Size	150*106*282mm	150*106*322mm	162*127*345mm	180*150*400mm	340*220*440mm
Weight	13.8KG	16KG	24KG	48KG	70KG

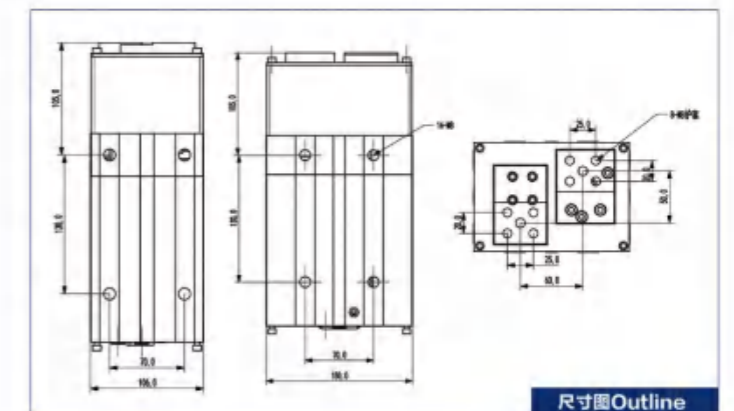
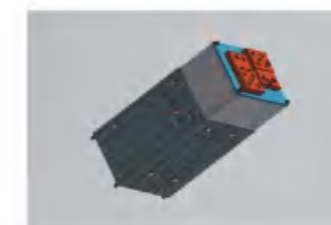
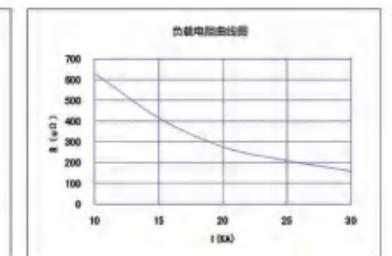
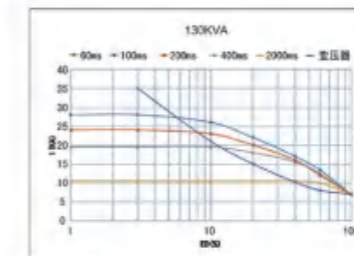

尺寸图Outline

# 15 AC Welding Controller

## Product Features

- Heat control method (Constant heat mode, Constant voltage mode and Constant current mode).
- Startup method (Level signal start and Pulse signal start) in the level signal start mode, the start signal must be maintained until the pre-pressing process is completed, otherwise the welding process will be interrupted, while the pulse signal mode has no special requirements.
- 3 Mode of Action ( Single point,Continuous 1 and Continuous 2) The difference between Continuous 1 and Continuous 2 is that in Continuous 2 mode, if the rest time is 0, it is single point, and if the rest time is greater than 0, it is continuous.In seam welding mode, the main processes are welding and interval.
- Action assistance method,This function is mainly used in continuous mode and seam welding mode.

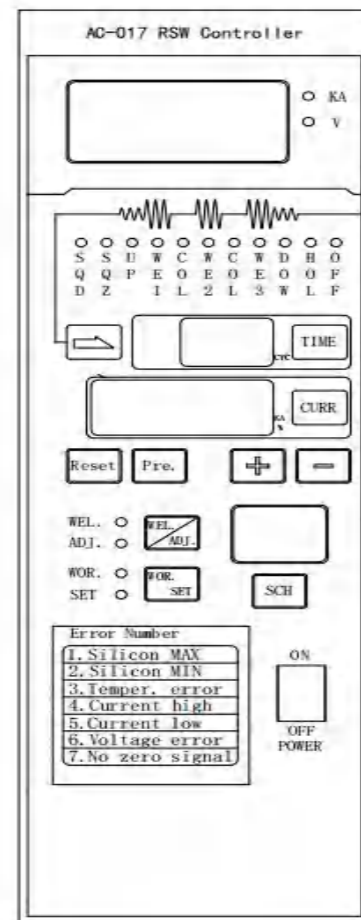

## Technical Parameters

Model	URAC
Input voltage (V)	Single-phase 380V,power fluctuation+10%,-20%;frequency 50Hz±1%
Air valve output rated voltage (V)	24V Valve output: DC24V±10% 220V Valve output: AC220V±10%
Air valve output rated current (A)	According to the sensor range
Operating temperature range (°C)	≤0.15A/each channel
Operating ambient humidity (%)	-5°C -50°C
Operating altitude (Km)	≤80%
Insulation class	1
Enclosure size (mm) Supply Voltage	Class F
Start signal	Start switch 1 , Start switch 2
Air valve actuated	2 Groups
Number of specification stores	8 Groups
Pre-pressure time (Periodic waveform/20ms)	0-99
Pressurization time (Periodic waveform/20ms)	0-99
Slow rise time (Periodic waveform/20ms)	0-99
Preheat time (Periodic waveform/20ms)	0-99
Cooling time (Periodic waveform/20ms)	0-99
Welding time (Periodic waveform/20ms)	0-99
Cooling time (Periodic waveform/20ms)	0-99
Tempering time (Periodic waveform/20ms)	0-99
Retarding time (Periodic waveform/20ms)	0-99
Holding time (Periodic waveform/20ms)	0-99
Rest time (Periodic waveform/20ms)	0-99

## 16 UR AC Transformer

### Product Features

- Transformer achieves localized heating and fusion of metal workpieces through low voltage and high current. Constructed with a high-permeability silicon steel core and copper windings, it offers high reliability and rapid response characteristics, making it suitable for automotive manufacturing, metal processing, and electronic component welding.
- Transformer secondary output has low voltage and high current.
- Transformers are vital core components in power transmission and electronic devices, achieving voltage transformation and efficient energy transfer through electromagnetic induction.
- One working frequency (50KHz or 60KHz).
- Built-in impedance compensation for stable performance. Low-voltage, high-current design for safe and efficient welding.
- Long lifespan with minimal maintenance.



### Transformer Specifications

Model	URA-100	URA-160	URA-200	URA-250
Primary power	380V	380V	380V	380V
Rated Power	100KVA	150KVA	200KVA	250KVA
Cooling Method	Water-cooling	Water-cooling	Water-cooling	Water-cooling
Input Frequency	50kHz	50kHz	50kHz or 60kHz	50kHz or 60kHz
Duty cycle	50%	50%	50%	50%
Secondary no-load Voltage	8.63V	9.5V	9.5V	10.0V
Short circuit Current	32KA	36KA	40KA	45KA
Continuous Current	8.2KA	9.5KA	11.9KA	14.0KA
Cooling Water Flow	12L/m	24L/m	24L/m	24L/m
Size	380*220*320mm	510*222*376mm	460*255*460mm	581*230*443mm
Weight	150KG	200KG	260KG	320KG

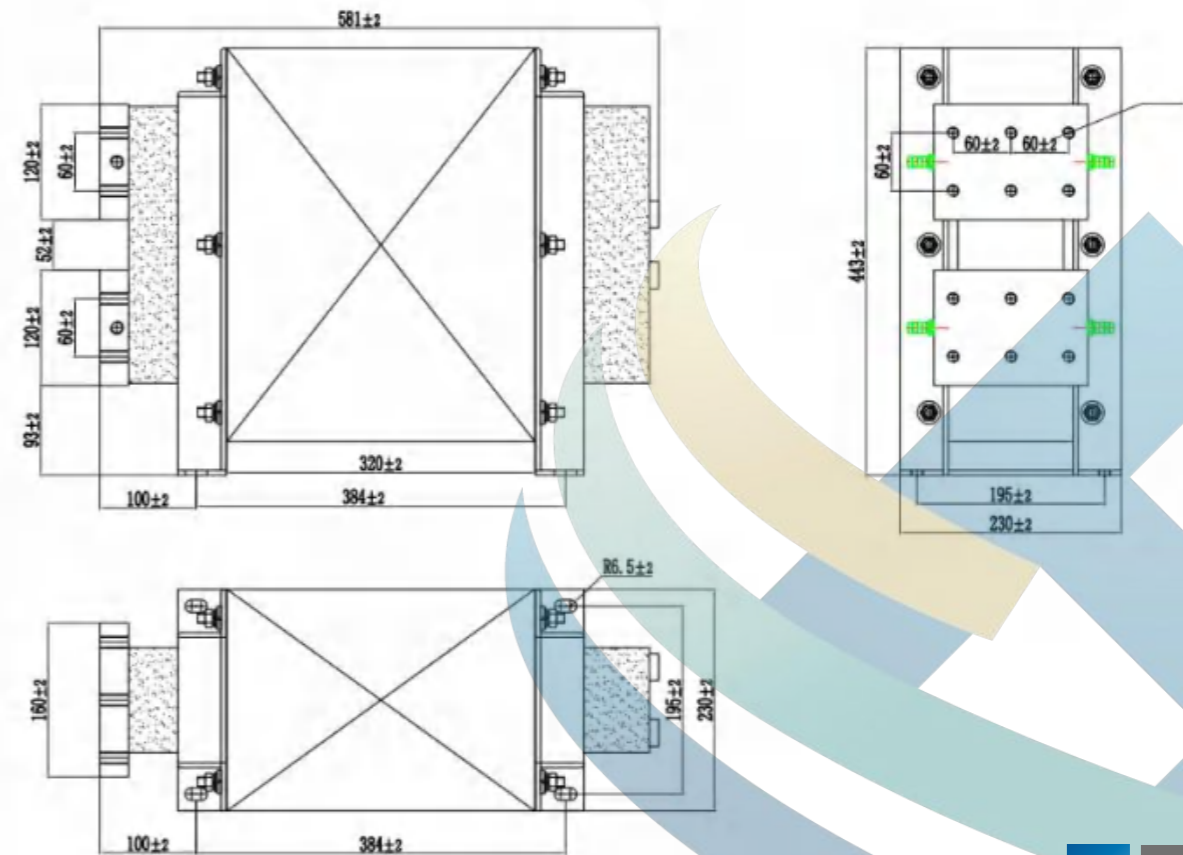

# 17 Welding Monitor

## HD-100B Welding Current Monitor

### Product Features

- Applicable to various types of resistance welding machines, it helps to improve the quality of welding.
- Welding current, welding time and lead angle data can be monitored.
- Automatic detection of defective products by setting current and welding time ranges.

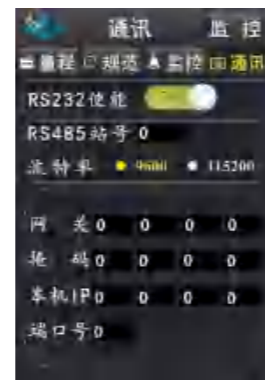

## HD-400B Universal Comprehensive Welding Monitoring

### Product Features

- It can detect various types of resistance welding machines and help improve welding quality.
- It monitors and determines key values such as welding current, voltage, power, welding time, pressure, displacement, etc., and saves about 5 million pieces of welding key data, preventing unstable welding, which can lead to defective products flowing into the next process.



### Monitor Specifications

Model	HD-100B	HD-400B
Input Power	AC 220V	
Measurement Model	AC /AC Inverter/DC Inverter/Energy Storage/Transistor Type	
Number Of Welding Specification	32 Group Norms	
Measurement Range	Current Range	0.1-199KA
	Voltage Range	/
	Power Range	/
	Power On Time	1-6000ms
	Conduction Angle	1%-100%
	Displacement Range	/
	Pressure Range	/
Data Storage	/	Stand-alone 5 million pieces/Upper system unlimited
Current Accuracy	≤1%	
External Communication Protocol	RS-232/RS-485/Ethernet ( Tcp-IP )	
Supported Languages	Chinese/English	Chinese/English/Japanese
Sizes	75*195*179.69mm	242*200*95mm
Operating Temperature	/	-15-50℃
Ambient Temperature	/	≤90% ( no condensation )

## 18 Pulse Heating Power

### Product Features

- 5-stage heating and constant temperature waveform
- Exquisite human-machine touch interface, real-time display of temperature curve, pressure curve, displacement curve and corresponding welding data, visualization of welding process.
- It can monitor the average effective value and instantaneous value of temperature, pressure, and displacement to control the welding quality.
- Support functions such as pressure monitoring, pressure triggering, displacement monitoring, and displacement melting depth interruption.
- Powerful database function, to store temperature, pressure, displacement and other values of ten of thousands of hot pressed joints, and supporting USB export.
- It can connect with upper computer welding network group control, connected to MES system to achieve visualization, dataization and intelligence of the entire welding process.



### Technical Parameters

Model		HT-300	HT-500
Supply Voltage		220V (50/60Hz)	
Inverter Frequency		10kHz	
Maximum output power		3kva	5kva
Temperature Setting Range		50-600 Celsius degree	
Welding specification number		255 Group	
Welding Time	Pre-squeeze Time	1-9999ms	
	Squeeze Time	1-9999ms	
	Up slope 1 Time	1-9999ms	
	Welding 1 Time	1-9999ms	
	Up 2 time	1-9999ms	
	Welding 2 time	1-9999ms	
	Up 3 Time	1-9999ms	
	Welding 3 Time	1-9999ms	
	Up 4 Time	1-9999ms	
	Weld 4 Time	1-9999ms	
	Hold Time	1-9999ms	
	Up 5 Time	1-9999ms	
	Weld 5 Time	1-9999ms	
	Rest Period	1-9999ms	
End Time	1-9999ms		
Heating Pulse times		5	
Cooling		Air Cooling	
Time Precision		0.01S	
Communication		Standard RS232,485. Customized TCP/IP	
Temperature Precision		+/- 2 degree celsius	
Weight		21Kg	22Kg
Size		500*205*325mm	

## 19 Energy Storage Welding Controller

### Product Features

- 5-stage heating and constant temperature waveform
- Exquisite human-machine touch interface, real-time display of temperature curve, pressure curve, displacement curve and corresponding welding data, visualization of welding process.
- It can monitor the average effective value and instantaneous value of temperature, pressure, and displacement to control the welding quality.
- Support functions such as pressure monitoring, pressure triggering, displacement monitoring, and displacement melting depth interruption.
- Powerful database function, to store temperature, pressure, displacement and other values of ten of thousands of hot pressed joints, and supporting USB export.
- It can connect with upper computer welding network group control, connected to MES system to achieve visualization, dataization and intelligence of the entire welding process.



### Technical Parameters

Model	ESW-200	ESW-300
Supply Voltage	3-phase 380V (50/60Hz)	
Capacitance	10000uf	20000uf
Voltage adjustment range	100-850V	
Welding specification number	17 Group	
Cooling	Air Cooling	
Communication	RS-485	
Heating stage	3	

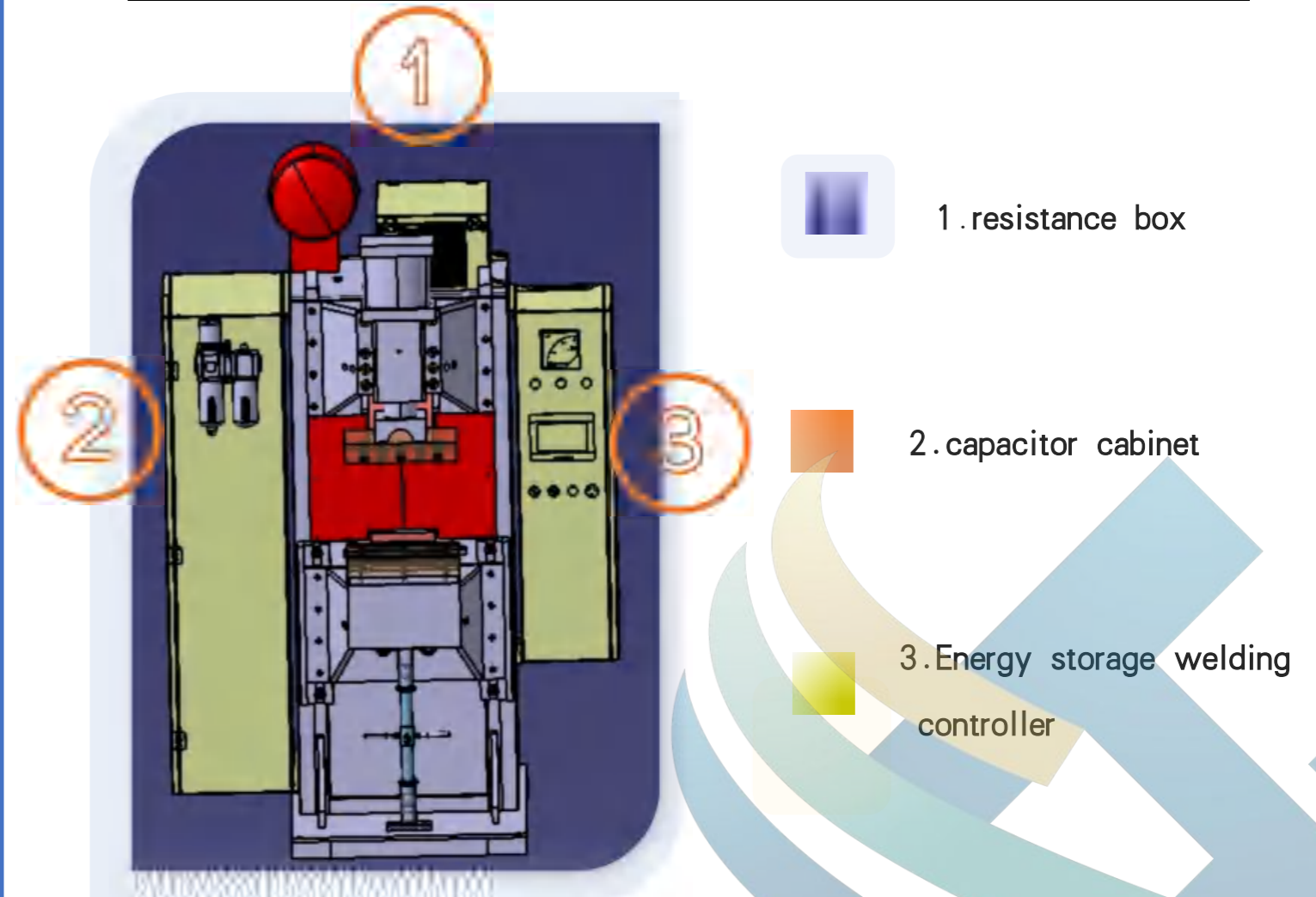

## 20 Welding Network Group Control System

### Product Features

- Single or multiple resistance welding machine network control, remote data collection, improve the efficiency of welding operations. Visualize the whole welding process.
- Support to display and save each welding value and corresponding welding waveform. Record the alarm and fault information of each equipment.
- Real-time operation status monitoring of multiple devices remote editing or importing and exporting of welding process parameters of the devices.
- Remotely monitor the current, voltage, power and other key values of the welding machine.
- Statistical analysis of welding data and production data.

应用	序列号	设备类型	设备名称	IP地址	端口	连接	在线	固件版本	协议编号	协议名称	设备说明
1		精密点焊机	IDP8210	192.168.0.1	8000			固件v3.0	WenDiTCP	文迪TCP	
2		精密点焊机	IDP8210	192.168.0.2	8000			固件v3.0	WenDiTCP	文迪TCP	
3		精密点焊机	IDP8210	192.168.0.3	8000			固件v3.0	WenDiTCP	文迪TCP	
4		精密点焊机	IDP8210	192.168.0.4	8000			固件v3.0	WenDiTCP	文迪TCP	
5		精密点焊机	IDP8210	192.168.0.5	8000			固件v3.0	WenDiTCP	文迪TCP	
6		精密点焊机	IDP8210	192.168.0.6	8000			固件v3.0	WenDiTCP	文迪TCP	
7		精密点焊机	IDP8210	192.168.0.7	8000			固件v3.0	WenDiTCP	文迪TCP	
8		精密点焊机	IDP8210	192.168.0.8	8000			固件v3.0	WenDiTCP	文迪TCP	
9		精密点焊机	IDP8210	192.168.0.9	8000			固件v3.0	WenDiTCP	文迪TCP	
10		精密点焊机	IDP8210	192.168.0.10	8000			固件v3.0	WenDiTCP	文迪TCP	
11		精密点焊机	IDP8210	192.168.0.11	8000			固件v3.0	WenDiTCP	文迪TCP	
12		精密点焊机	IDP8210	192.168.0.12	8000			固件v3.0	WenDiTCP	文迪TCP	
13		精密点焊机	IDP8210	192.168.0.13	8000			固件v3.0	WenDiTCP	文迪TCP	
14		精密点焊机	IDP8210	192.168.0.14	8000			固件v3.0	WenDiTCP	文迪TCP	
15		精密点焊机	IDP8210	192.168.0.15	8000			固件v3.0	WenDiTCP	文迪TCP	
16		精密点焊机	IDP8210	192.168.0.16	8000			固件v3.0	WenDiTCP	文迪TCP	
17		精密点焊机	IDP8210	192.168.0.17	8000			固件v3.0	WenDiTCP	文迪TCP	

## Welding network group control software

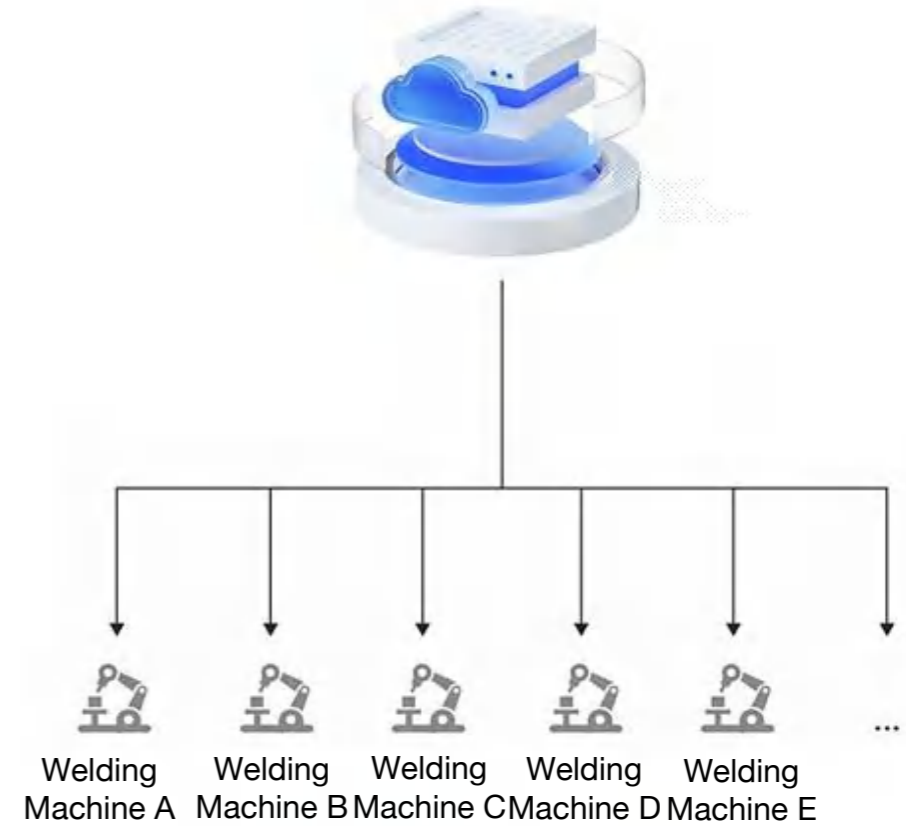

# 21 Welding Quality Monitoring System

## Product Features

- Suitable for monitoring all types of resistance welding machines (DC/AC/AC-DC/HD/Storage/Transistor).
- It can monitor the current, voltage, power, energizing time parameters of resistance welding machine, as well as pressure and displacement parameters (optional).
- It can set the upper and lower limits of key welding values such as current, voltage, power, pressure, displacement, etc., with over-limit alarms.
- Real-time acquisition and display of each welding current, voltage, power and other real welding waveforms, as well as the corresponding welding data for analysis.
- Record and store welding data such as current, voltage, power, etc. of each welding, and historical alarm and fault information, up to millions of items.
- Equipped with a wealth of I/O interfaces, supporting a variety of communication protocols (RS-232, RS-485, Ethernet, etc.).
- Built-in multi-mode welding counter to meet the counting requirements of different welding workpieces on different occasions, and at the same time can monitor the output.

## Diagram Of System Composition

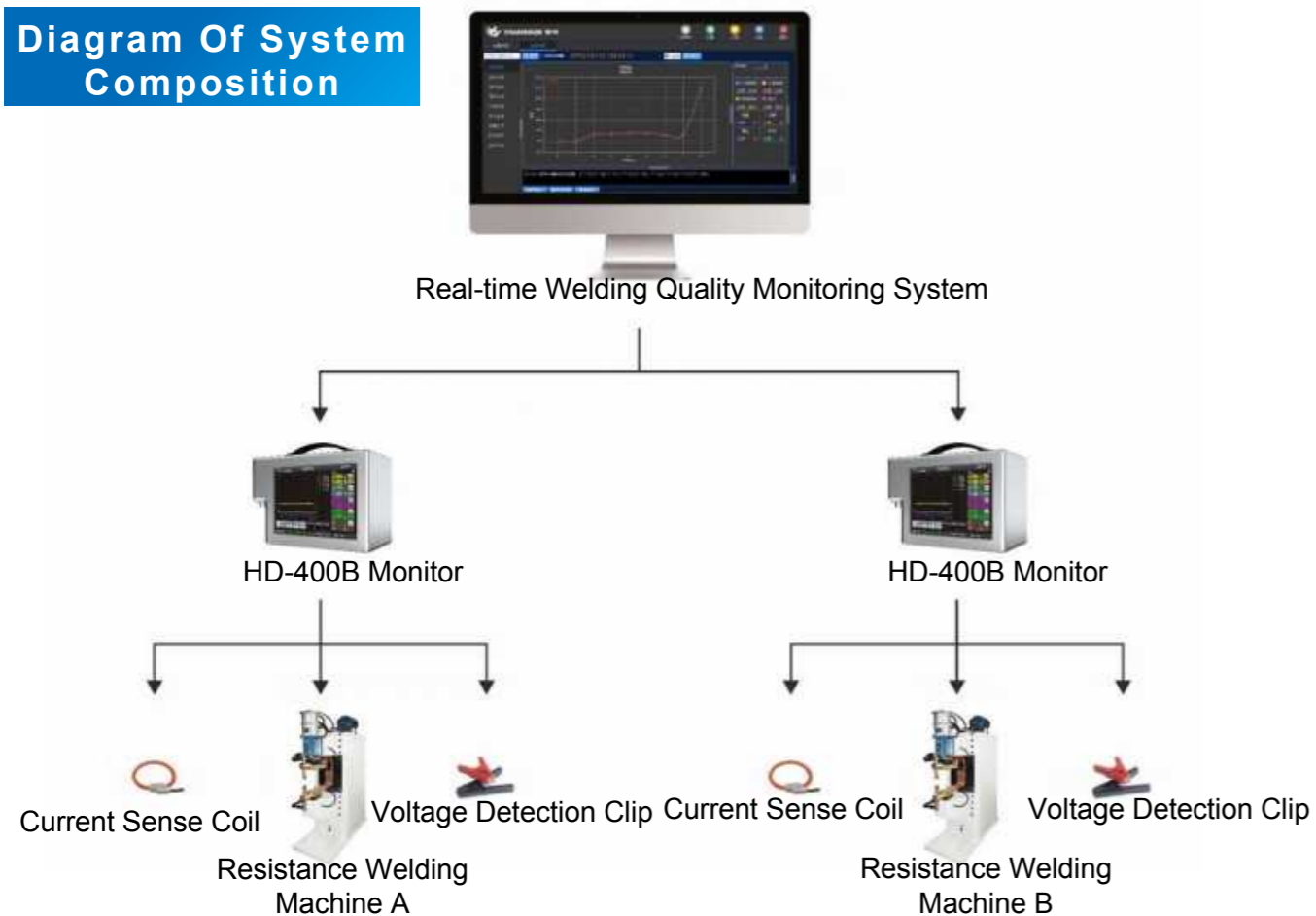

## Diagram Of System Composition

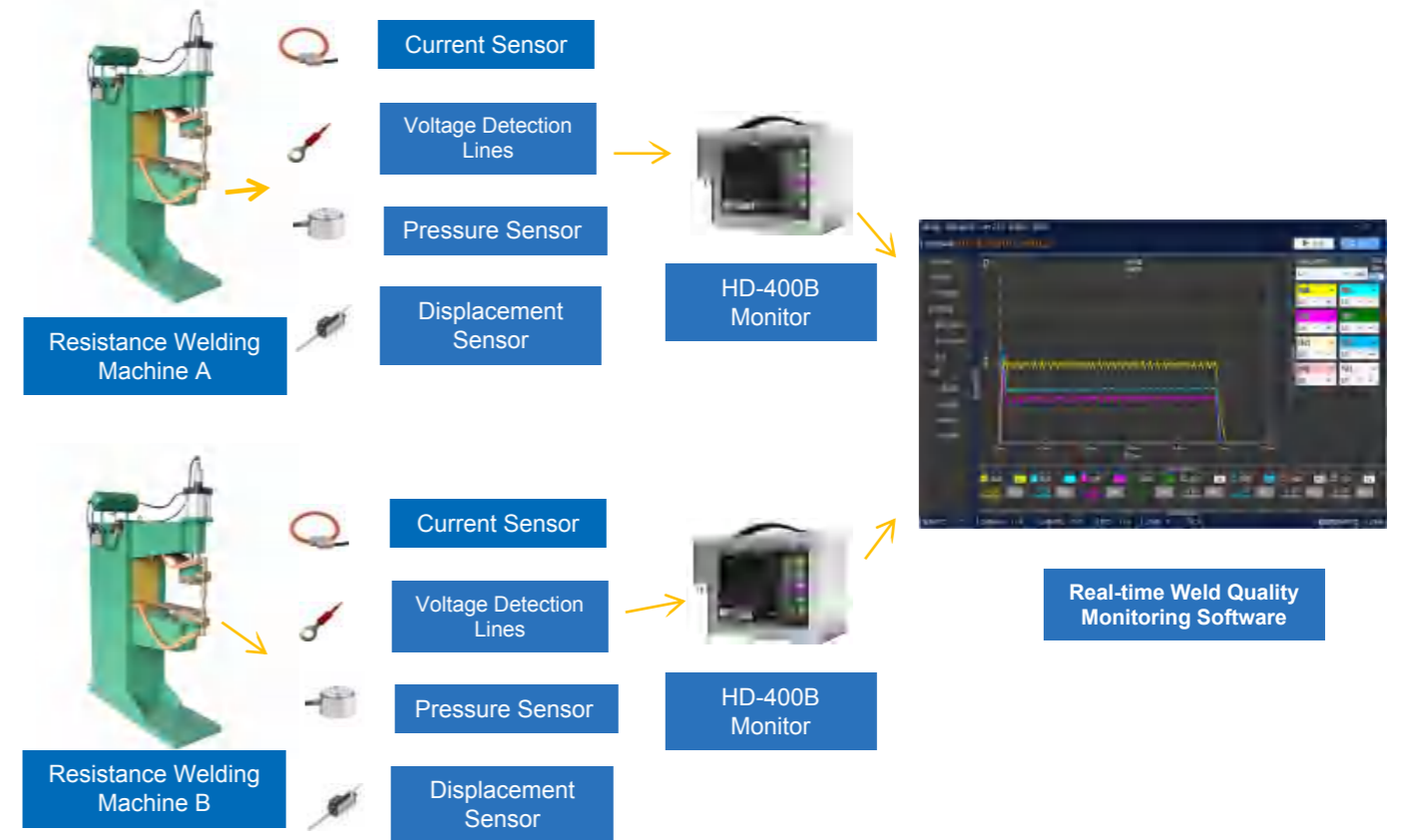

## 22 Servo Head Controller

### Product Features

- By adopting closed-loop pressure control, high-precision pressure regulation, pressure titering, pressure monitoring etc.
- Support pressure monitoring and displacement melt depth monitoring to meet high standard requirements for workpiece melt depth consistency.
- Support setting 32 sets of programmable welding pressure parameters.
- Support display of pressure and displacement dynamic curve waveforms, storage of pressure and displacement data, and upload of data and waveforms to MES system.



### Technical Parameters

Model	HL-100
Supply Voltage	220V (50/60Hz)
Control Method	Pressure control mode/position control mode/torque control mode
Pressure control range	According to the sensor range
Displacement monitoring range	0-25MM
Welding specification number	32 Group
Cooling	Air Cooling
Servo brand	Panasonic
Communication	Standard RS232,485. Customized TCP/IP
Temperature Precision	+/- 2 degree celsius
Pressure accuracy	+/-2N



## 23 Pneumatic Or Servo Spot Welding Mechanism

### Product Features

- HD-DHQ series pneumatic spot welding mechanism has the characteristics of high precision, flexible pressurization, good stability and long service life.
- The linear guide design is used to ensure the accuracy and repeatability of welding.
- The pressure following mechanism is adopted, which can achieve rapid and accurate pressurization operation even at very low welding pressure.
- Support micro trigger switch or photoelectric switch to stabilize the triggering of welding power supply and improve quality and productivity.
- The vertical integration design ensures the stability of the pressure point and solves the shaking problem of the sensor grip design.
- The pressurizing mechanism is easy to disassemble, which is beneficial for integration of automated equipment.
- Supports optional pressure sensor, combined with HUANDZK welding power supply, it can monitor the consistency of welding pressure, or set it to start discharging when the pressure reaches a certain level, ensuring that the pressure of each welding is stable and consistent.
- Supports optional displacement sensor, combined with the HUANDZK welding power supply displacement monitoring power-off function, to ensure that the penetration depth of each welder is consistent.
- HD-DHS series servo spot welding mechanism adopts a vertically integrated design to ensure the stability of the pressure point, solve the shaking problem of the sensor grip design, and use fully imported brand mechanical accessories. To ensure its excellent dynamic response capability, as well as high precision, high rigidity, flexible pressurization, high stability, and long service life.
- Can be paired with H-100 head controller to achieve adjustable speed, adjustable standby point, high-precision pressure control adjustment, pressure triggering, pressure monitoring, displacement monitoring, melt depth control and other functions.

### Technical Parameters

Model	HD-DHQ		HD-DHS
Drive method	pneumatic		Servo
Pressure method	Pneumatic + spring		Servo + spring
Pressure range	10-110N/15-200N	20-300N/40-500N	80-1200N
Electrode travel	Customization		
Electrode size	Standard 6-12MM, Customization		
Pressure sensor	0-10V analog output (optional)		
Displacement sensor	0-10V analog output (optional)		
Weight	≈12KG	≈27KG	≈40KG

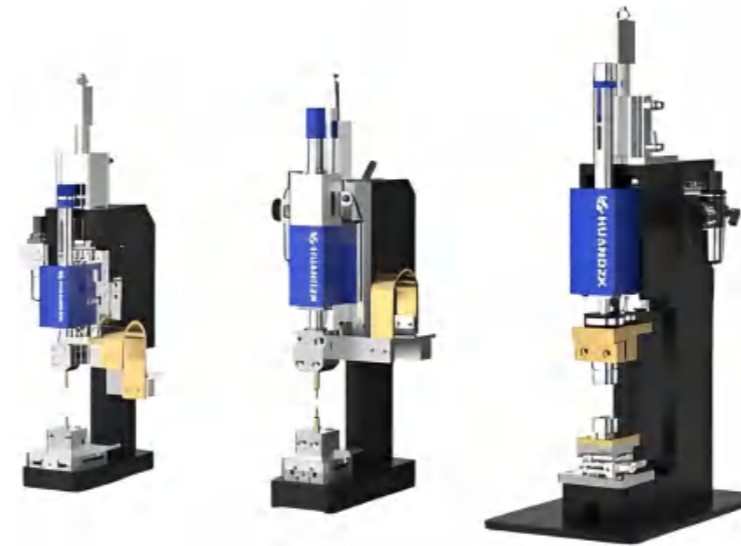

HD-DHQ series pneumatic spot welding mechanism



HD-DHS series servo spot welding mechanism

## 24 Pneumatic Or Servo Clamp Welding Mechanism

### Product Features

- HD-JHQ series pneumatic clamp welding mechanism utilizes a lightly pressurized design to minimize vibration and achieve a highly durable structure, ensuring the trajectory accuracy and process repeatability of each welding motion meet stringent user requirements.
- It offers excellent dynamic response, high precision, high rigidity, flexible pressurization, high stability, and a long service life.
- An optional pressure sensor, combined with the HUANDZK welding power source, can dynamically display the pressure waveform curve to monitor the consistency of welding pressure, or set the discharge to start when the pressure reaches a certain level, ensuring that the pressure of each weld is stable and consistent.
- Optional displacement sensor, combined with the HUANDZK welding power supply displacement monitoring interrupt function, ensures that the penetration depth of each welder is consistent, or monitors the consistency of the workpiece penetration value.
- HD-JHS series servo clamp welding mechanism adopts a vertically integrated design to ensure the stability of the pressure point and solve the shaking problem of the sensor grip design.
- It also uses imported brand accessories such as Panasonic, Tokyo Clockwork, Shangyin, Omron, Wika, and Mismis. To ensure its excellent dynamic response capability as well as high precision, high rigidity, flexible pressurization, high stability, and long service life.
- Can be paired with HL-100 head controller to achieve adjustable speed, adjustable standby point, high-precision pressure control adjustment, pressure triggering, pressure monitoring, displacement monitoring, melt depth control and other functions.
- It is suitable for welding motor stator wire hooks and enameled wires, terminals and terminals, terminals and enameled wires, motor rubber cover inductors and protectors, inductors and Y-type terminals, resistors and Y-type terminals, etc., and is suitable for precision resistor welding applications with small space and high requirements.

### Technical Parameters

Model	HD-JHQ			HD-JHS		
Drive method	pneumatic			Servo		
Pressure method	Pneumatic + spring			Servo + spring		
Pressure range	30-300N	50-700N	70-1200N	80-700N	150-1200N	300-2200N
Electrode travel	Customization			40MM	30MM	45MM
Electrode size	Standard 6-12MM, Customization			Standard 8-12MM, Customization		
Pressure sensor	0-10V analog output (optional)			0-10V analog output		
Displacement sensor	0-10V analog output (optional)			0-10V analog output		
Weight	≈7KG		≈15KG	≈20KG		

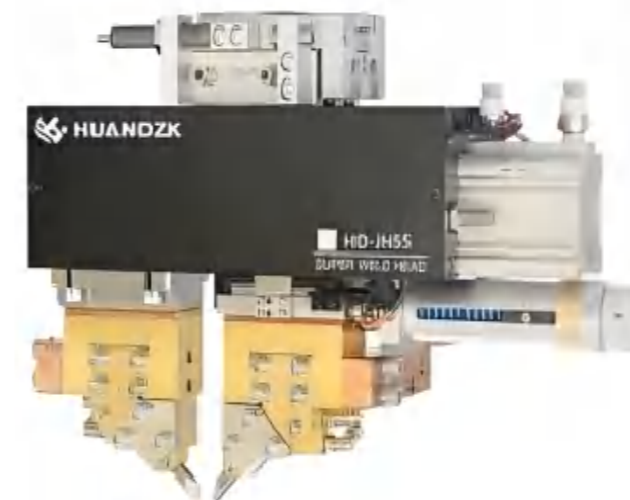

HD-JHQ series pneumatic clamp welding mechanism



HD-JHS series servo clamp welding mechanism

## 25 Welding Gun

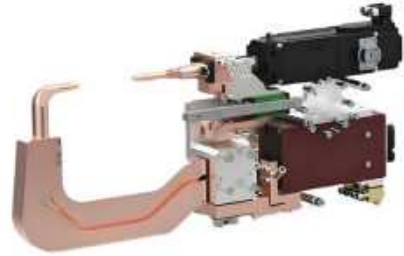

Type C Welding Forceps

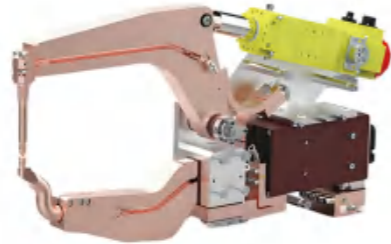

Robotic Welding Forceps



Manual Welding Forceps

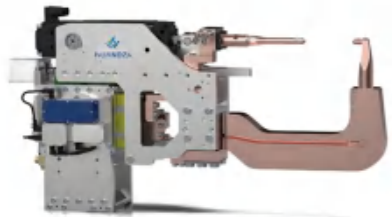

Type C Welding Forceps

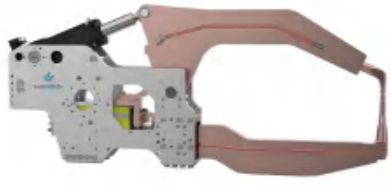

Robotic Welding Forceps



Manual Welding Forceps

Welding Guns Can Be **Customized**

## 26 Accessory

Various Types Of Welding Heads To Meet The Different Needs Of **Customers**



HD-YF pressure square welding series mechanism



HD-SH Double point welding series mechanism



Handheld Welding Head

### Welding Electrode Head

- Commonly used electrode head materials are copper, tungsten, molybdenum, we will choose the appropriate electrode material according to the customer's product.

