



峰美機械  
FENG MEI

FENG MEI MACHINERY

FENG MEI MACHINERY  
雙切換過濾桶中心出水機 / 紙帶式過濾中心出水機 / 雙過濾式標準機  
Double Pathway Filtration CTS / Paper Filtration CTS / Double filtration design



峰美機械有限公司  
FENG MEI MACHINERY CO.,LTD.

📍 408 台中市南屯區五權西路三段1巷87-2號

✉ E-mail:fengmei.co@msa.hinet.net

☎ TEL: 04-23801849 FAX:04-23809136

🌐 www.fengmei.com.tw



# FENG MEI MACHINERY

中心出水系統 CNC COOLING SYSTEM

## OURS Service

緊密的溝通與合作  
close communication and cooperation  
帶給您造極的效益  
Bring you the ultimate benefits

01

客製化需求  
Customized requirements  
· 與客戶雙向溝通  
· Communication  
· 共同研討開發  
· Joint development discussion



02

成品/測試流程化  
Product-ORIENTED  
· 組裝生產  
· Finished product assembly test  
· 出貨檢驗  
· Shipping inspection



03

客戶服務  
Customer service  
· 專業改機  
· Professional modification  
· 到廠安裝  
· To factory installation



## 公司簡介

提供客戶最有價值的產品與定制化的有效解決方案。堅持提昇專業研發能力與建立自有品牌，並配合市場需要來研發新產品，以增進現有產品的功能與多樣化，掌握市場銷售動脈，提升全球市場佔有率。秉持品質優先、技術創新原則，以誠正勤儉、專業創新、顧客至上、品質第一等理念積極拓展海內外市場，提供各產業所需的油壓解決方案。我們不斷致力於研發全自動精密過濾設備，以及環保減廢的各項產品，及各式客製化濾心。已是許多工具機製造者油壓單元的獨佔的設計與製造者。我們的產品線已擴展且已變得更加創新來符合一直在進步的金屬切削、壓鑄、和塑膠射出工具機等的需求。專門在生產高壓切削系統來幫助國內外的客戶解決難切削材料加工問題。經過這些年的努力，我們已經研發成功一系列的產品提供給不同型態的工具機使用。我們依舊會以客戶優先的立場持續創新，以客戶至上的目標持續邁進，一同與我們的客戶創造雙贏。公司專精研製生產高壓切削冷卻系統，以安全、節省成本、提升競爭力為經營理念，提供國內外客戶解決各種難切削材料的加工問題。

Introduction to high pressure cooling water through spindle system(CTS)。

Provide customers with the most valuable products and customized effective solutions

We insist on improving professional R&D capabilities and establishing our own brands, and develop new products in line with market needs to enhance the functionality and diversification of existing products, grasp the market sales artery, and increase global market share.

Adhering to the principles of quality first and technological innovation, we actively expand domestic and overseas markets with the concepts of integrity, diligence, professional innovation, customer first, and quality first, and provide hydraulic solutions required by various industries.

We are constantly committed to the research and development of fully automatic precision filtration equipment, various environmentally friendly and waste-reducing products, and various customized filter elements.

It has become the exclusive designer and manufacturer of hydraulic units for many machine tool manufacturers. Our product lines have expanded and become more innovative to meet the ever-advancing needs of metal cutting, die casting, and plastic injection machine tools.

Specializing in the production of high-pressure cutting cooling systems to help domestic and foreign customers solve difficult-to-cut material processing problems. After these years of hard work, we have successfully developed a series of products for use on different types of machine tools. We will continue to innovate with a customer-first attitude, continue to move forward with the goal of customer first, and create a win-win situation with our customers together.

The company specializes in the development and production of high-pressure cutting cooling systems. With the business philosophy of safety, cost saving and enhancing competitiveness, it provides domestic and foreign customers with solutions to the processing problems of various difficult-to-cut materials.

## FM-S201

無水箱式簡易型是運用FM-S201 系統，2HP馬達泵浦抽取機台水箱切削液，經由第一道濾袋過濾後（需定期更換濾袋），由第二道機密濾罐出口，經過機台主軸高壓出水。

Without water tank simple type adopt “FM-S201” system, 2HP motor pumping cooling water go through 1st filter bag (need periodic inspection), then into 2nd precise filter output offer high pressure cooling water to spindle.

| 規格型號                       | S201                          | S301                          | S501                          | S701                            |
|----------------------------|-------------------------------|-------------------------------|-------------------------------|---------------------------------|
| 適用切削液<br>Pump              | 水油10:1<br>齒輪泵<br>柱塞泵<br>油水通用  | 水油10:1<br>齒輪泵<br>柱塞泵<br>無油水   | 水油10:1<br>齒輪泵<br>柱塞泵<br>無油水   | 水油10:1<br>齒輪泵<br>柱塞泵<br>無油水     |
| 最大工作壓力<br>Working Pressure | 20bar<br>(For Nop)            | 30bar                         | 50bar                         | 70bar                           |
| 過濾精度<br>Filter             | 25µm~150µm                    |                               |                               |                                 |
| 馬達功率<br>Horsepower         | 2HP<br>220V/60Hz<br>380V/50Hz | 3HP<br>220V/60Hz<br>380V/50Hz | 5HP<br>220V/60Hz<br>380V/50Hz | 7.5HP<br>220V/60Hz<br>380V/50Hz |

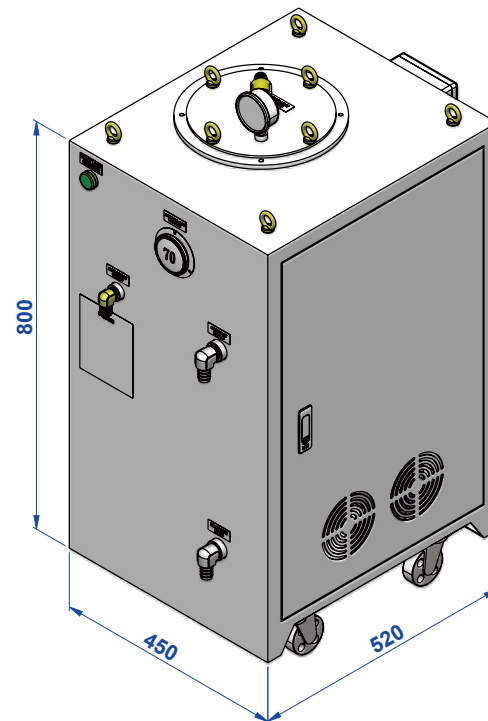

標準無水箱式  
Simple type pressure coolant system





# FENG MEI MACHINERY

中心出水系統 CNC COOLING SYSTEM

## 雙切換濾袋系統 Double Filtration Pathway



### FM-W201

FM-W201是由抽水馬達抽取機台切削液經FM-W201 由濾袋過濾後（需定期更換濾袋），進入FM-W201 水箱，由精密濾罐出水，再由機台主軸高壓出水。

雙濾袋如一個濾袋阻塞不用停機，切換另一個濾袋，都可正常使用。

FM-W201 pumping cooling waer into filer bag, after filtration use 2HP motor increase pressure pass precise filter offer clean water to spindle.

Our design is double filtration pathway, in case one filtration bag blocked,user can easy switch to spare filtration bag, chang blocked one without stop whole system.

| 規格型號                       | W201                       | W301                         | W501                         | W701                         |
|----------------------------|----------------------------|------------------------------|------------------------------|------------------------------|
| 適用切削液<br>Pump              | 水油10:1<br>齒輪泵              | 水油10:1<br>齒輪泵<br>柱塞泵<br>油水通用 | 水油10:1<br>齒輪泵<br>柱塞泵<br>油水通用 | 水油10:1<br>齒輪泵<br>柱塞泵<br>油水通用 |
| 最大工作壓力<br>Working Pressure | 20bar<br>(For Nop)         | 30bar                        | 50bar                        | 70bar                        |
| 過濾精度<br>Filter             | 25µm~150µm                 |                              |                              |                              |
| 馬達功率<br>Horsepower         | 2HP 220V/60Hz<br>380V/50Hz | 3HP 220V/60Hz<br>380V/50Hz   | 5HP 220V/60Hz<br>380V/50Hz   | 7.5HP 220V/60Hz<br>380V/50Hz |

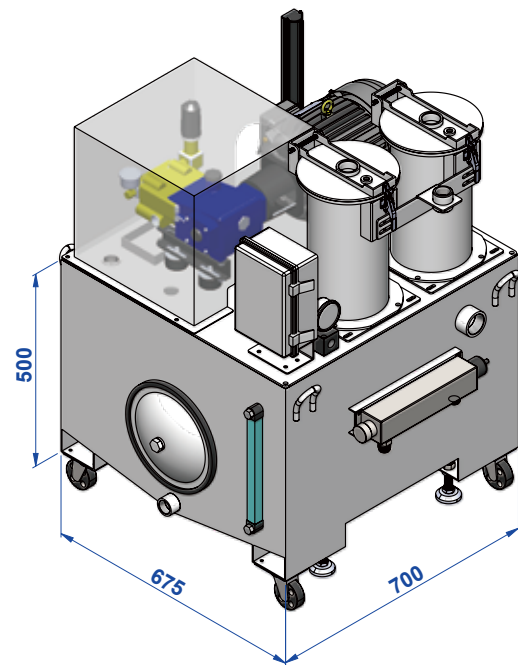

### FM-P063

由抽水馬達經紙袋機過濾進入水箱，由3HP馬達幫浦加壓後，經精密濾罐出水由機台主軸高壓出水。

Motor pumping cooling water into paper filtration water tank, adopt 3HP motor to increase pressure go through precise filter to offer cooling water to spindle.

## 紙帶式過濾中心出水機 Paper Filter



| 規格型號                     | P063                       | P065                         | P067                         |
|--------------------------|----------------------------|------------------------------|------------------------------|
| 適用切削液<br>Pump            | 水油10:1<br>齒輪泵              | 水油10:1<br>齒輪泵<br>柱塞泵<br>油水通用 | 水油10:1<br>齒輪泵<br>柱塞泵<br>油水通用 |
| 輸出壓力<br>Working Pressure | 30bar                      | 56bar                        | 70bar                        |
| 紙帶過濾精度<br>Filter         | 5µm~150µm                  |                              |                              |
| 紙帶寬度<br>Paper Width      | 50mm~700mm                 |                              |                              |
| 濾罐精度<br>Pressure Filter  | 25µm~100µm                 |                              |                              |
| 馬達功率<br>Horsepower       | 2HP 220V/60Hz<br>380V/50Hz | 3HP 220V/60Hz<br>380V/50Hz   | 5HP 220V/60Hz<br>380V/50Hz   |

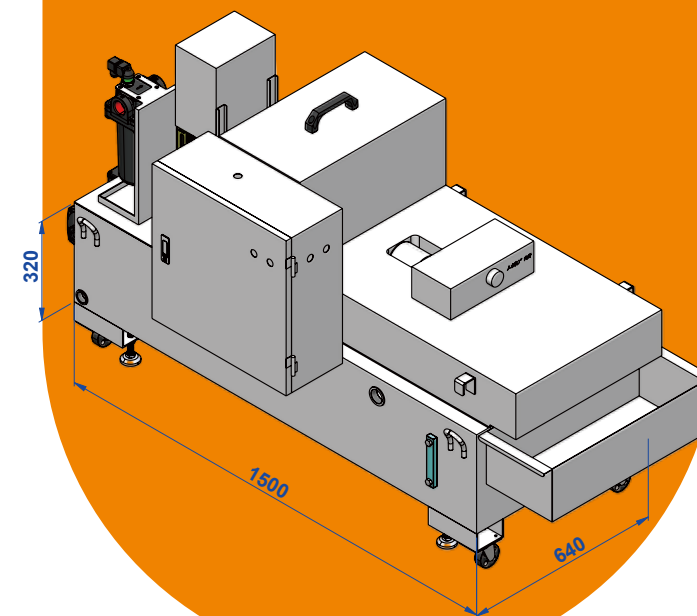



# FENG MEI MACHINERY

中心出水系統 CNC COOLING SYSTEM

## 雙過濾式標準機 Double Pressure Switches



### FM-P

- 1.過濾金屬非金屬
- 2.搭配任意高壓泵進行過濾，增加刀具壽命。
- 3.過濾雜質，減少切削液更換次數。

1. Filtration metal and non-metallic.
2. Can match any pump to do filtration.
3. Filtration dust or sundries, reduce cooling water change frequently saving your cost.

FM-P 中心出水紙袋過濾機 規格表：

| 型號       | 過濾能力<br>L/min | 濾紙寬度 | A   | B    | C    | 水箱開孔尺寸    |
|----------|---------------|------|-----|------|------|-----------|
| FM-P-20  | 20            | 500  | 430 | 1033 | 544  | 667*550   |
| FM-P-40  | 40            | 500  | 430 | 1208 | 544  | 842*550   |
| FM-P-60  | 60            | 500  | 430 | 1260 | 544  | 922*550   |
| FM-P-80  | 80            | 700  | 430 | 1215 | 744  | 922*750   |
| FM-P-120 | 120           | 700  | 432 | 1410 | 744  | 1109*750  |
| FM-P-160 | 160           | 700  | 432 | 1550 | 794  | 1326*800  |
| FM-P-240 | 240           | 1000 | 432 | 1550 | 1060 | 1326*1065 |

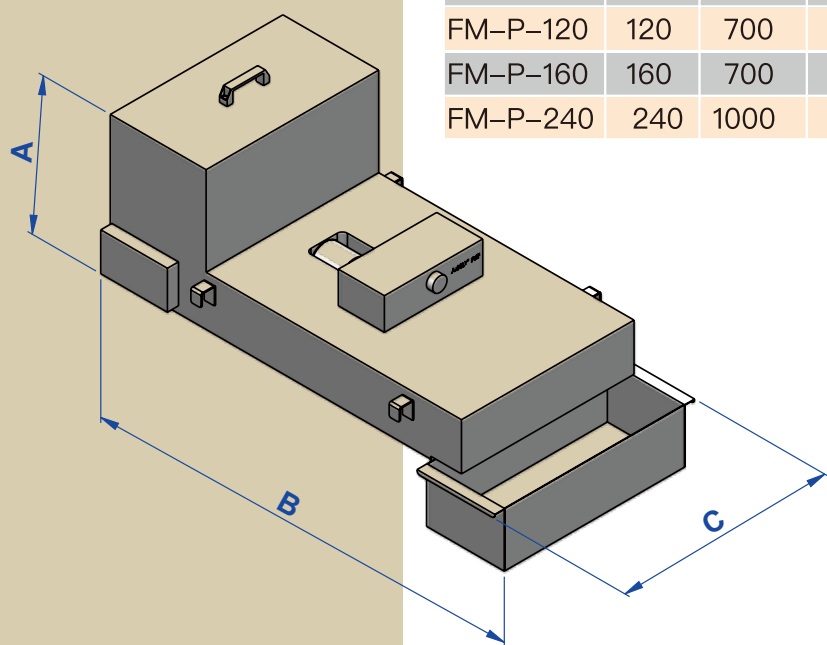

### FM-F 701

- 1.變頻可任意選取壓力
- 2.冷卻控制切削液溫度，提高加工效率。
- 3.可搭配各家控制系統，讀取並控制我們的設備，為自動化最佳選擇。

1. Adopt inverter motor, can easy change pressure by touch-screen.
2. Can control cooling temperature, increse machining efficiency.
3. Match all conteroller system, easy contact and reading our equipments it's aut mation best choice.

| Model               | FM-CTS       |
|---------------------|--------------|
| 壓力 Working Pressure | 70bar        |
| 流量 Suction Volume   | 28 Liter/min |
| 馬力 Horsepower       | 5HP/60Hz     |
| 冷卻能力 Cooling Power  | 2000 Kcal    |
| 抽水能力 Max Flow Rate  | 30 Liter/min |

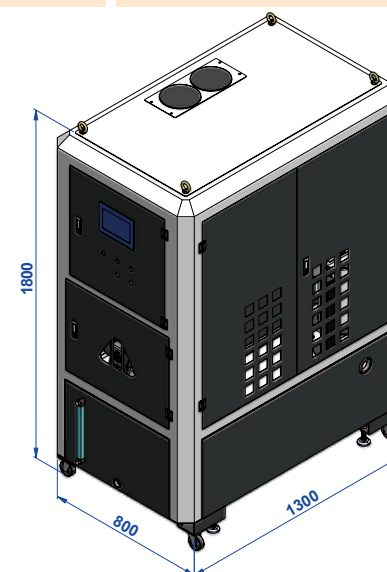

## 智能型中心出水系統 AI Type CTS





# FENG MEI MACHINERY

中心出水系統 CNC COOLING SYSTEM

## 水質淨化機 Water Purifier

### 水質淨化機

水質淨化機

功能：1.油水分離

2.抑菌

為你節約切削液，並解決味道問題。

Water Purifier

Function: 1. Oil-water separation

2. Sterilization

Save cutting fluid for you and solve the smelling problem.

● 氣動雙隔膜泵浦壓力2-6公斤

● 濾袋5μ~100μ

● 電壓110V/220V

● 臭氧機

● 油水分離機

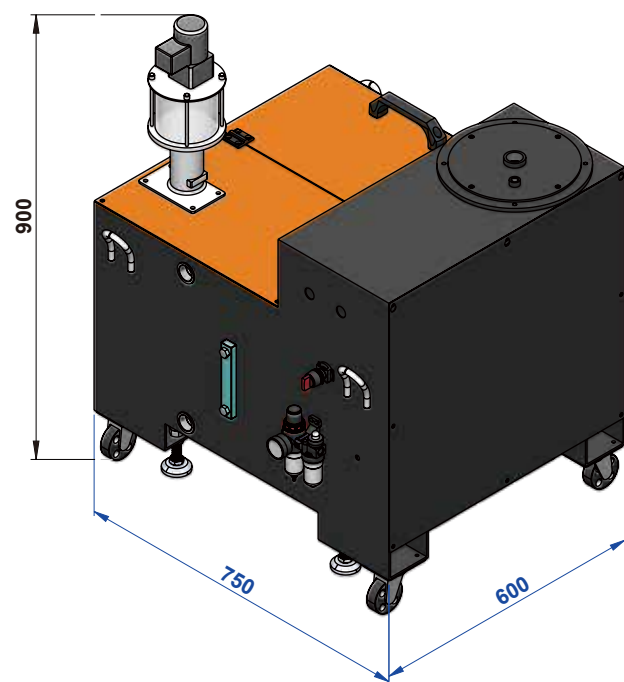

### CTS F705

70BAR高壓中心出水，採用雙重過濾方式，確保切削液品質，提升加工效率，增加刀具壽命。

Deluxe model 70bar high pressure cooling water through spindle system adopts double filtration method. Ensure cutting fluid quality, improve processing efficiency, and increase tool life.

| 規格型號   | 20CTS                        | 30CTS                       | 50CTS                       | 70CTS                        |
|--------|------------------------------|-----------------------------|-----------------------------|------------------------------|
| 適用切削液  | 水油10:1<br>齒輪泵<br>柱塞泵<br>油水通用 | 水油10:1<br>齒輪泵<br>柱塞泵<br>無油水 | 水油10:1<br>齒輪泵<br>柱塞泵<br>無油水 | 水油10:1<br>齒輪泵<br>柱塞泵<br>無油水  |
| 最大工作壓力 | 20bar<br>(For Nop)           | 30bar                       | 50bar                       | 70bar                        |
| 過濾精度   | 40μm~150μm                   |                             |                             |                              |
| 馬達功率   | 2HP 220V/60Hz<br>380V/50Hz   | 3HP 220V/60Hz<br>380V/50Hz  | 5HP 220V/60Hz<br>380V/50Hz  | 7.5HP 220V/60Hz<br>380V/50Hz |

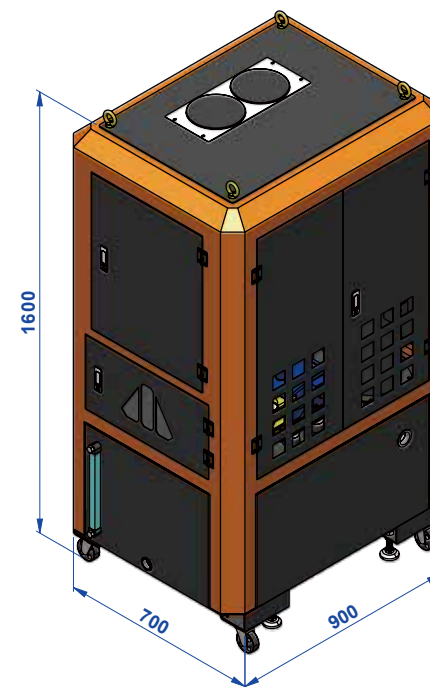

豪華型高壓中心出水機  
Deluxe model 70bar high pressure cooling water through spindle system





# FENG MEI MACHINERY

中心出水系統 CNC COOLING SYSTEM



磁鐵過濾機 Magnetic Separator



鼓式紙袋過濾機 Drum Type Paper Filter



遠心分離機 Centrifuge Separator



## 選購配件 Option



RIX 日製旋轉接頭  
RIX Rotary Joint



RIX 日製旋轉接頭  
RIX Rotary Joint



梭動閥  
Shuttle valve



油冷卻器  
Oil cooler



高壓泵浦  
Piston high pressure pump



調壓閥  
Regulator



渦旋分離裝置  
Cyclone



各式濾芯  
Filter Element



紫外線殺菌燈  
UV Sterilization